





# MAIDSTONE

www.MaidstoneSupply.com

SKU: 121-ETF6-6

Unpack and check all the parts, and read the instructions.

PART NO.	DESCRIPTION	QTY
CK-1	HANSHOWER HEAD	1
CK-2	HANSHOWER HANDLE	1
CK-3	HANSHOWER HOSE	1
CK-4	HANSHOWER HOSE WASHERS	2
CK-10	HANSHOWER FAUCET CRADLE	1
CK-11	HANSHOWER CRADLE WASHER	1

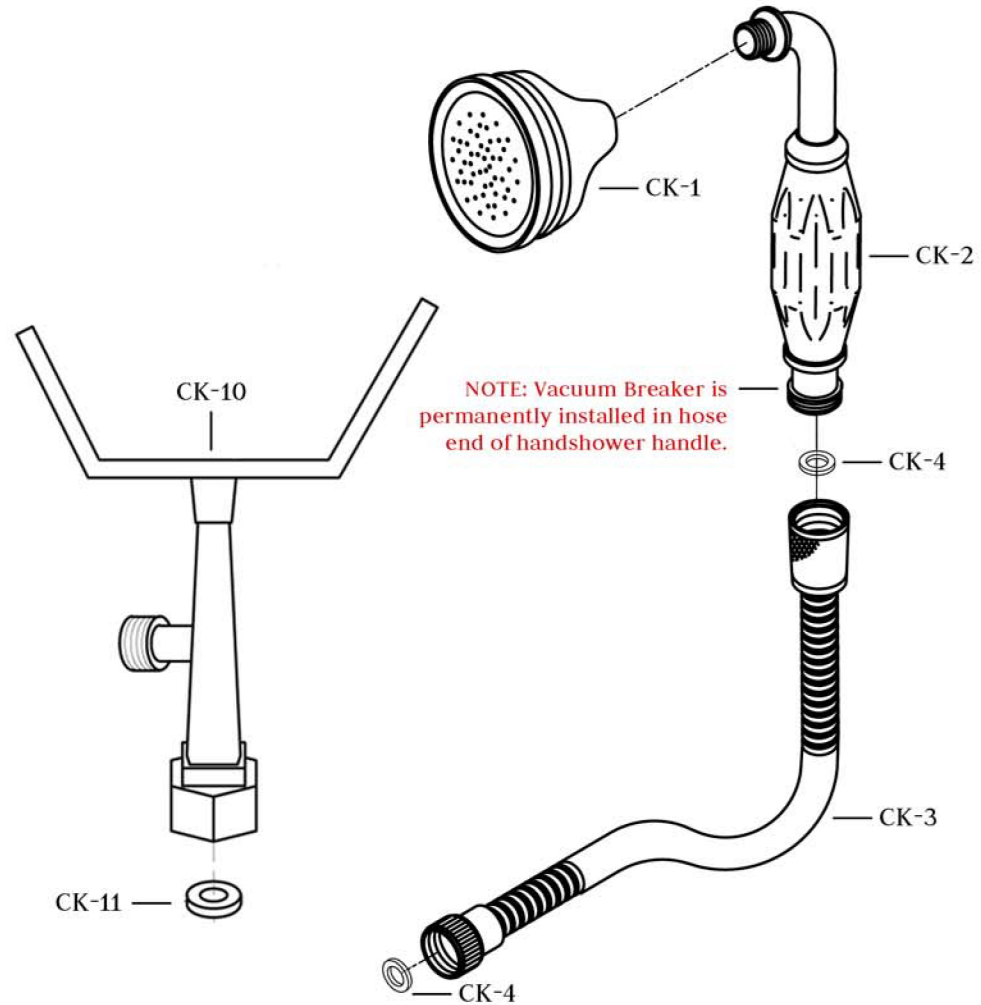



# MAIDSTONE

www.MaidstoneSupply.com

SKU: 121-ETF6-6

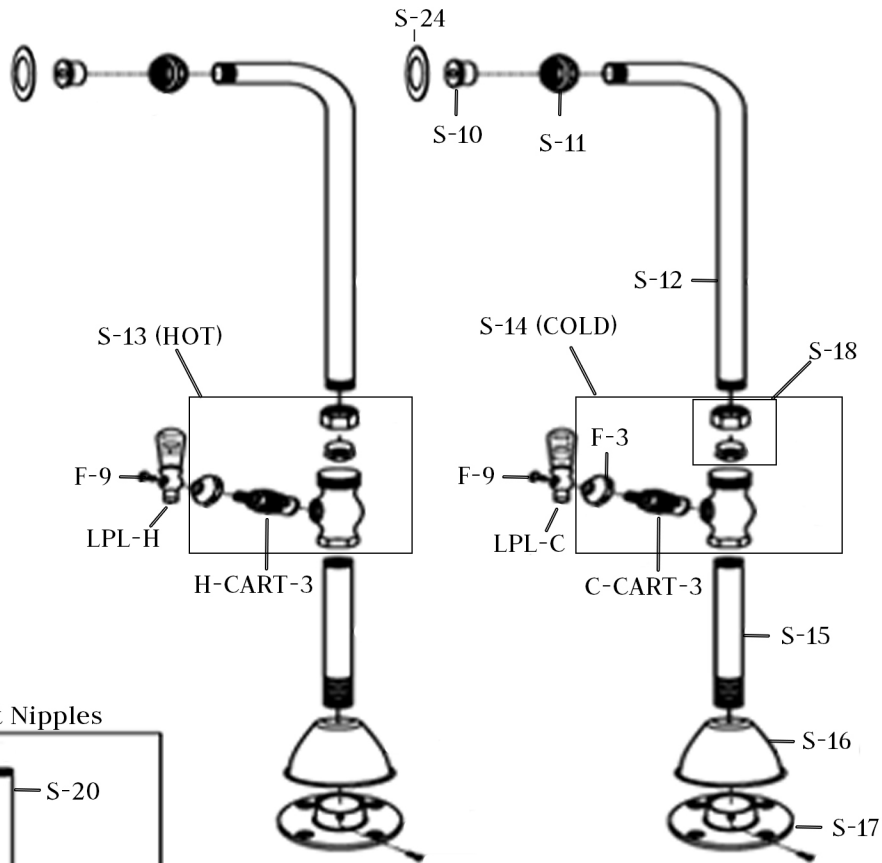

Unpack and check all the parts, and read the instructions.

ITEM	DESCRIPTION	QTY
C-CART-3	COLD STEM	1
H-CART-3	HOT STEM	1
E-12	FLANGE	2
E-DRYWALL SCREW	DRYWALL SCREW	4
E-PLASTIC ANCHOR	PLASTIC ANCHOR	4
E-SET SCREWS	SCREW (FINISHED)	4
F-3	BELL NUT	2
F-9	SCREW	2
LPL-C	COLD HANDLE	1
LPL-H	HOT HANDLE	1
RMN3	3" NIPPLE	2
S-10	THREADED CONNECTOR	2
S-11	NUT	2
S-12	SHORT THROW TUBE	2
S-15	7.5" NIPPLE	2
S-16	ESCUTCHEON	2
S-17	FLANGE	2
S-18	NUT WITH FLANGE	2
S-19	6" NIPPLE	2
S-20	9" NIPPLE	2
S-21	HARDWARE BAG	1
S-22	LOOP INCLUDES E-SET SCREWS	2
S-23	12" TUBE	2
S-24	WASHER	2

### Adjustable Height Nipples

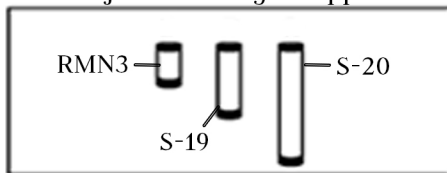

### Wall Brace

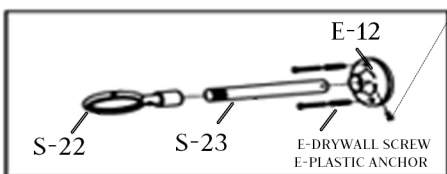

### E-SET SCREWS

### Parts Below Escutcheon

