



# HEKMAN®

A HOWARD MILLER COMPANY

## ASSEMBLY INSTRUCTION FOR 26121 ROUND DINING TABLE

### HARDWARE LIST

NO.	ITEM	DESCRIPTIN	QTY.
1		JCB Bolt M8X40 MM	4
2		Flat washer M8X25 MM	4
3		Allen wrench	1

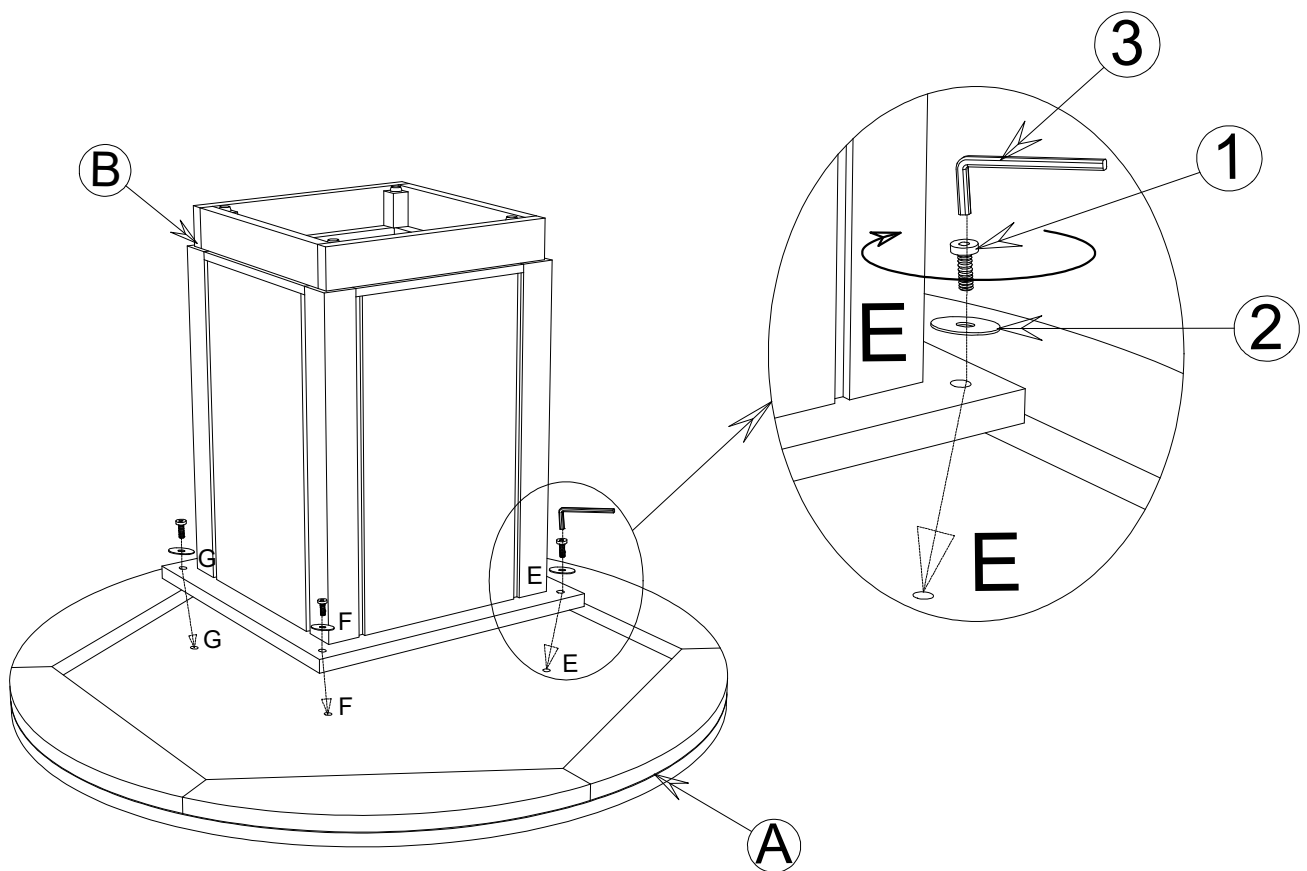

### TO ASSEMBLY :

STEP 1 : Unpack round dining table and turn the top assembly (A) upside down. on a clean, soft surface.

STEP 2 : Match the wood base (B). use matching marks E F G H - on top (A).

STEP 3 : Align holes in wood base (B) with holes on bottom of top (A) and slide it into position.

STEP 4 : Thread the flat washer(2) , JCB bolt (1) to wood base (B) . Do not tighten bolts fully until all bolts are started.

STEP 5 : Tighten bolts in step 4 fully with Allen wrench (3) then carefully turn the round dining table upright.