



EN

FR

GRIDDLE CART

23-INCH DOUBLE BURNER

29-INCH TRIPLE BURNER

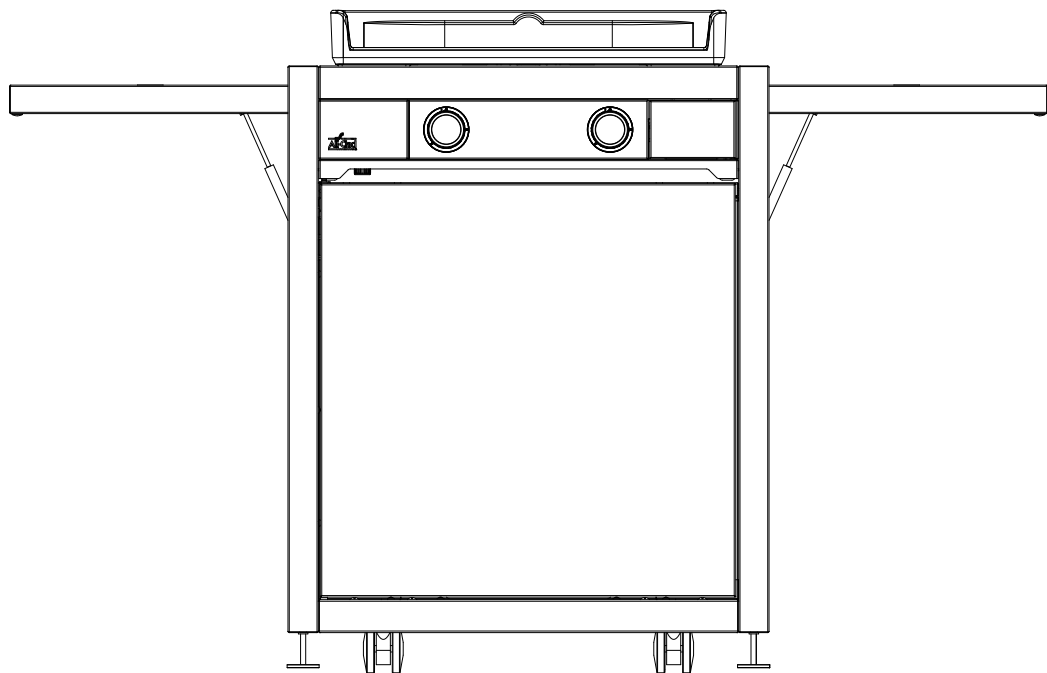

ASSEMBLY INSTRUCTIONS
INSTRUCTIONS DE MONTAGE

V1-JUNE25

NOTES - REMARQUES



EN Essential: Phillips and slotted screwdrivers, wrench, Allen key, assembly gloves

Recommended: Cordless screwdriver with long bit attachment, mat, assembly with 2 people

Assembly time: approximately 3 hours

FR Indispensable : Tournevis cruciforme et à fente, clé plate, clé Allen, gants de montage

Recommandée : Visseuse sans fil avec embout long, tapis, montage à 2 personnes

Temps de montage: environ 3 heures

NOTES - REMARQUES

BEFORE USE

Read the installation instructions carefully. They contain important instructions for the use, safety and maintenance of the cart. Failure to observe these instructions may result in serious injury or damage to property (burns, explosions, fires, etc.). The instructions should be kept in a safe place and passed on to any subsequent users. The product may only be used for its intended purpose in accordance with these instructions.



Assembly instruction:

Always assemble the cart on cardboard or a protective surface to avoid scratches on both the cart surface and the floor. Wear appropriate gloves during assembly to protect your hands. Never assemble the cart directly on the floor.

EN

IMPORTANT SAFETY INSTRUCTIONS

- Open the lid from your griddle before starting or using it.
- Only use standard 20 lbs (9 kg) propane tank to operate the griddle on your cart.
- Always operate your griddle with cart in a well-ventilated area.
- Ensure that the griddle with cart is placed on a flat and stable surface during operation.
- Ensure that the wheels of the cart are locked before use to prevent unintentional movement.
- Never store an additional (spare) gas tank near the griddle with cart while it is in use.
- Do not place the gas tank on the side trays of your griddle cart.
- Do not lift or move the cart by the side trays. Do not lean on the side trays.
- Do not move the cart while the griddle is in operation, as parts of the cart may become extremely hot.
- Keep children and pets away from the griddle while it is in use.
- Do not move the cart until the griddle has completely cooled down.
- Never move the cart while the gas tank is stored in the lower shelf.
- Always position the griddle in the center of the cart. Alternatively, keep the sides and back of the cart as far away as possible from the griddle to avoid overheating from radiant heat.
- Ensure that the griddle does not touch the cart at the back or sides while in operation.
- Extraordinary maintenance, such as part replacements or repairs in case of malfunctions, must only be carried out by manufacturer- or an authorized dealer.
- The maximum weight capacity of the griddle cart is 90 lbs / 40 kg, do not place more than 22 lbs / 10 kg on each shelf.

NOTES - REMARQUES

CLEANING AND MAINTENANCE

EN

- Never apply cleaning or degreasing products directly to the outdoor griddle cart, as this may cause discoloration. Instead, always use a damp cloth or sponge to apply the cleaning products.
- Disconnect the gas tank from the griddle before storing it . Store the gas tank in a dry, well-ventilated location away from heat sources.
- If the griddle is not intended to be used for a long time, it is recommended to store it in a dry, weather-protected location.
- All-Clad offers a range of specially designed protective covers to optimally safeguard your product when not in use.

WARRANTY

Warranty Duration: The manufacturer's warranty is valid for 2 years from the date of purchase.

Warranty Claims: For all warranty inquiries, please contact your retailer.

Exclusions from the Warranty:

- Damage caused by external factors such as lightning, water, etc.
- Operation outside the guidelines specified in this manual.
- Failure to follow the safety instructions.
- Improper use of the device.
- Modifications to the device that alter its original properties.
- Repairs or interventions not performed by an authorized dealer.
- Damage caused by neglecting maintenance instructions or insufficient protection of the product during non-use.

AVANT L'UTILISATION

Lire attentivement la notice de montage. Elle contient des instructions importantes pour l'utilisation, la sécurité et l'entretien de ce chariot. Le non-respect de ces consignes peut entraîner des blessures graves ou des dommages matériels (brûlures, explosions, incendies, etc.). Les instructions doivent être conservées soigneusement et, le cas échéant, transmises aux utilisateurs ultérieurs. Le chariot ne doit être utilisé que pour l'usage prévu, conformément aux présentes instructions.



Consigne de montage :

Effectuez toujours le montage du chariot sur un carton ou une surface protectrice afin d'éviter les rayures sur la surface du chariot et sur le sol. Portez des gants appropriés lors du montage pour protéger vos mains. Ne montez jamais le chariot directement à même le sol.

FR

CONSIGNES DE SÉCURITÉ IMPORTANTES

- Ouvrez le capot de votre plancha avant de la mettre en marche ou de l'utiliser.
- Utilisez uniquement des bouteilles de gaz d'un poids maximum de 20 lbs / 9 kg pour faire fonctionner votre plancha sur le chariot.
- Utilisez toujours votre plancha avec chariot dans un endroit bien ventilé.
- Assurez-vous que la plancha avec chariot soit posée sur une surface plane et stable pendant son fonctionnement.
- Assurez-vous que les roues du chariot sont verrouillées avant utilisation pour éviter tout mouvement involontaire.
- Ne stockez jamais une bouteille de gaz supplémentaire (de rechange) à proximité de la plancha avec chariot lorsqu'elle est en marche.
- Ne placez pas la bouteille de gaz sur les plateaux latéraux de votre chariot de plancha.
- Ne soulevez ni ne déplacez le chariot par les plateaux latéraux. Ne vous appuyez pas sur les plateaux latéraux.
- Ne déplacez pas le chariot pendant le fonctionnement de la plancha, car certaines parties peuvent devenir extrêmement chaudes.
- Maintenez les enfants et les animaux à l'écart de la plancha lorsqu'elle est en marche.
- Ne déplacez pas le chariot avant que la plancha ne soit complètement refroidie.
- Ne déplacez jamais le chariot lorsque la bouteille de gaz est rangée sur l'étagère inférieure.
- Positionnez toujours votre plancha au centre du chariot. Sinon, éloignez autant que possible les côtés et l'arrière du chariot pour éviter toute surchauffe causée par la chaleur rayonnante.
- Assurez-vous que la plancha ne touche ni le chariot à l'arrière ou sur les côtés pendant son fonctionnement.
- Les travaux de maintenance exceptionnels, tels que le remplacement de pièces ou les réparations en cas de panne, doivent être effectués exclusivement par un personnel agréé par le fabricant ou le distributeur.
- La capacité de charge maximale du chariot de la plancha est de 90 lbs / 40 kg, ne placez pas plus de 22 lbs / 10 kg sur chaque étagère.

NOTES - REMARQUES

NETTOYAGE ET ENTRETIEN

FR

- Ne jamais appliquer directement des produits de nettoyage ou de dégraissage sur le chariot de la plancha, car cela pourrait entraîner une décoloration. Utilisez toujours un chiffon humide ou une éponge pour appliquer les produits.
- Débranchez la bouteille de gaz de la plancha avant de la ranger. Conservez la bouteille de gaz dans un endroit sec, bien ventilé et éloigné de toute source de chaleur.
- Si vous n'utilisez pas votre plancha pendant une longue période, il est recommandé de la ranger dans un endroit sec, à l'abri des intempéries.
- All-Clad propose une gamme de housses de protection spécialement conçues pour protéger votre chariot et votre plancha quand ceux-ci ne sont pas utilisés.

GARANTIE

Durée de la garantie : La garantie du fabricant est valable 2 ans à partir de la date d'achat du produit.

Réclamations de garantie : Pour toute demande de garantie, veuillez contacter votre revendeur.

Exclusions de garantie :

- Les dommages causés par des facteurs externes tels que la foudre, l'eau, etc.
- L'utilisation en dehors des directives spécifiées dans ce manuel.
- Le non-respect des consignes de sécurité.
- Une utilisation inappropriée de l'appareil.
- Les modifications apportées à l'appareil qui en altèrent les propriétés d'origine.
- Les réparations ou interventions effectuées par un réparateur non agréé.
- Les dommages causés par le non-respect des consignes d'entretien ou une protection insuffisante du produit lorsqu'il n'est pas utilisé.

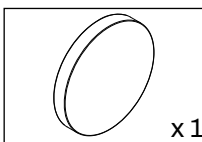
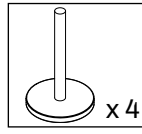
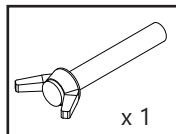
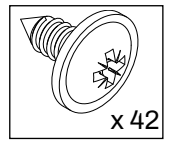
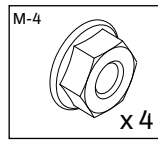
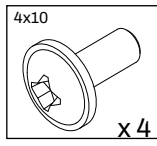
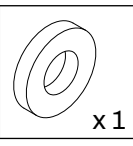
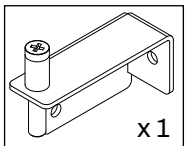
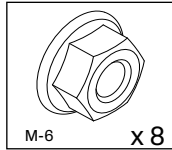
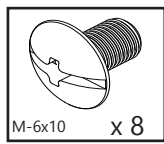
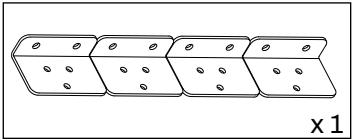
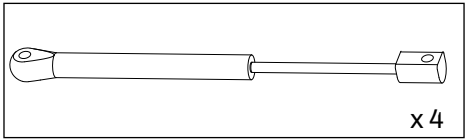
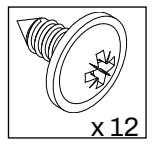
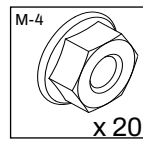
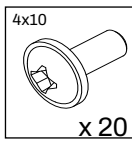
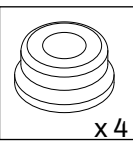
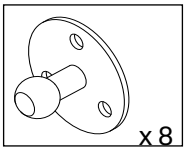
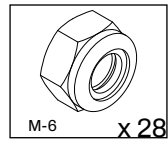
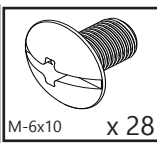
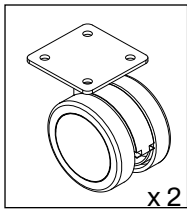
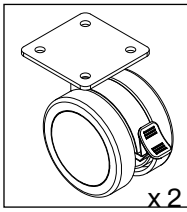
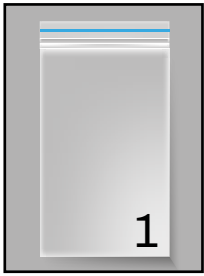

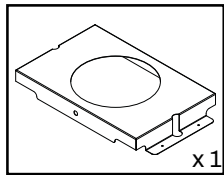
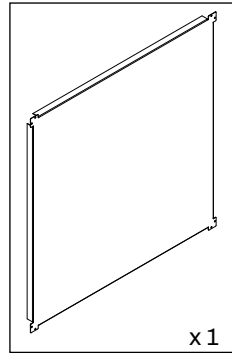
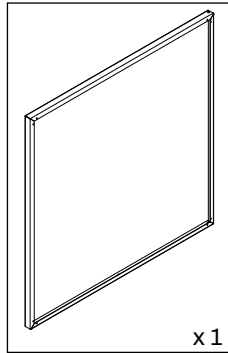
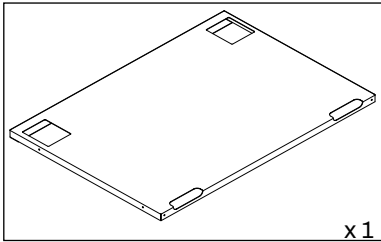
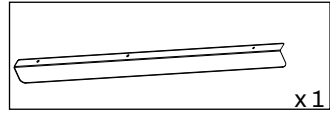
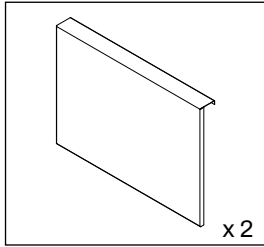
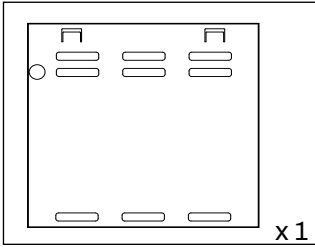
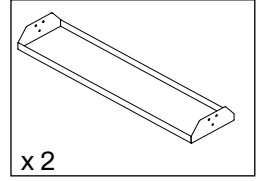
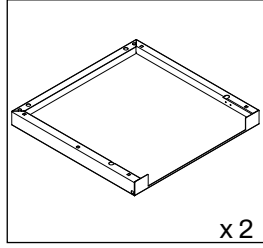
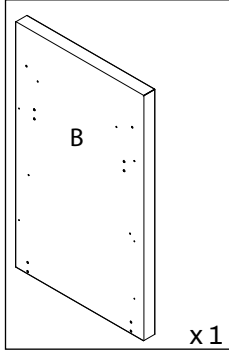
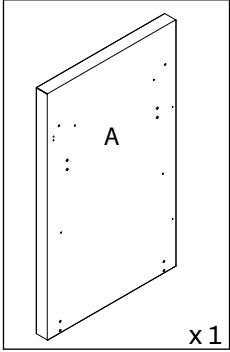
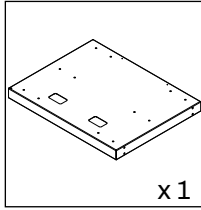
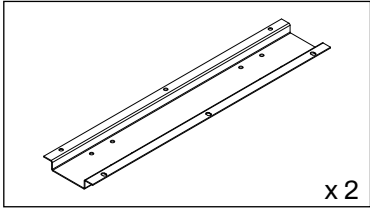

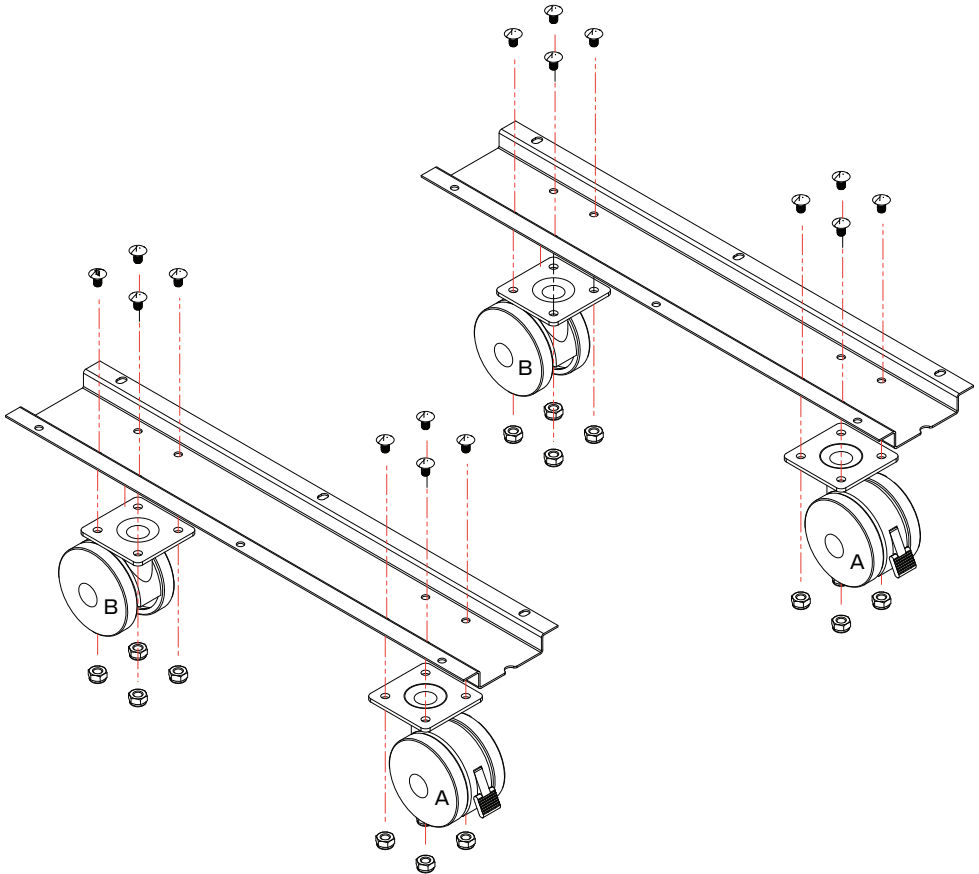
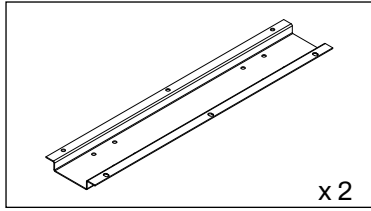
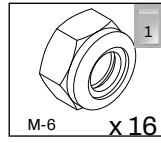
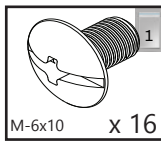
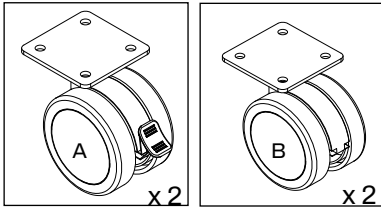

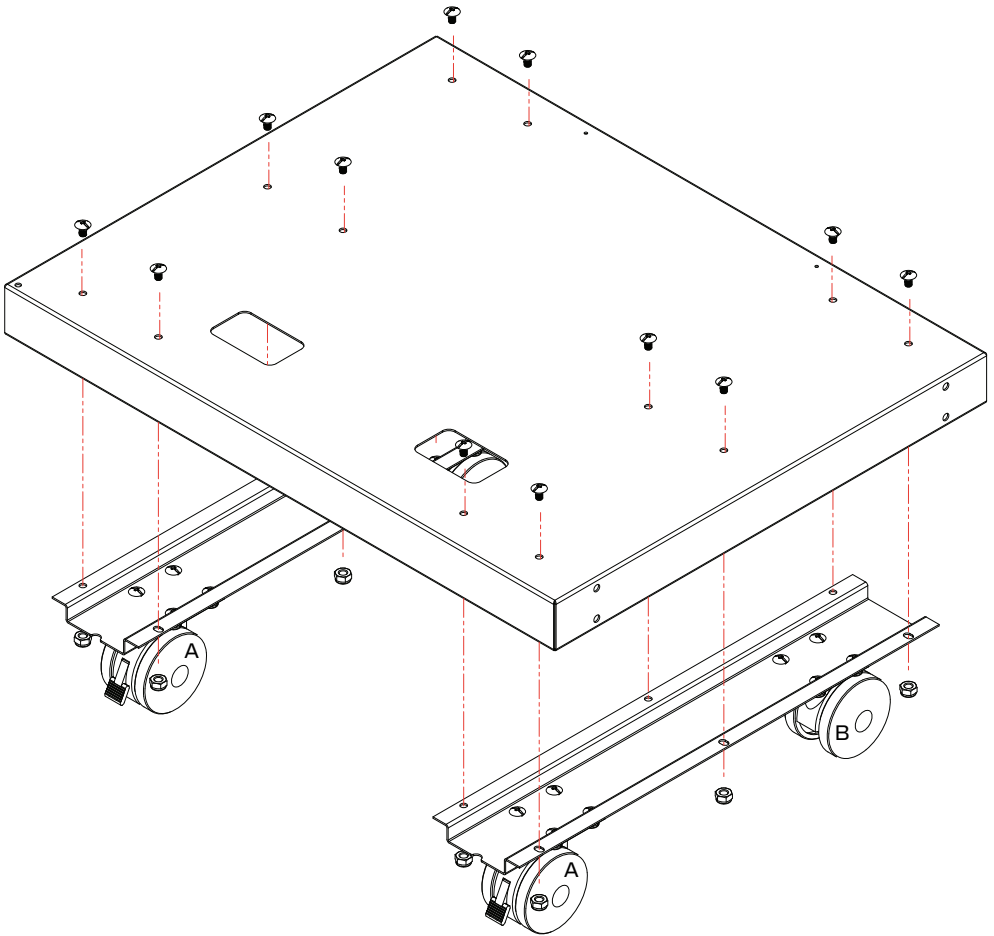
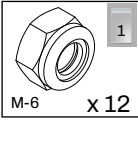
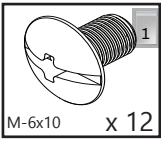
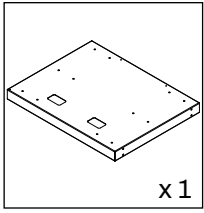

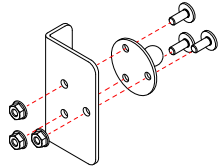
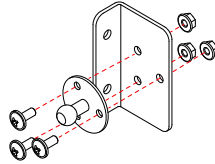
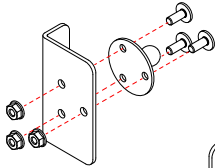
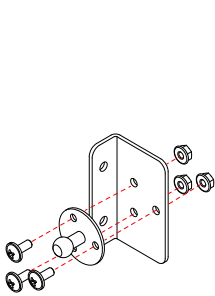
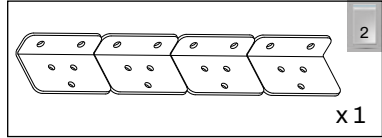
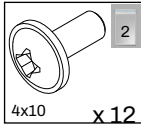
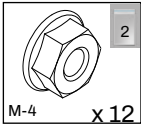
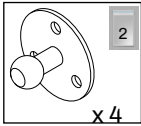

A & B

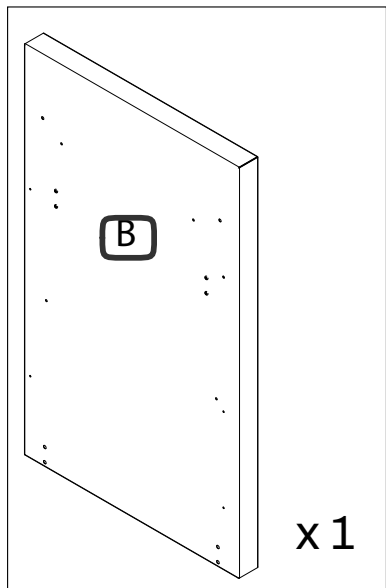
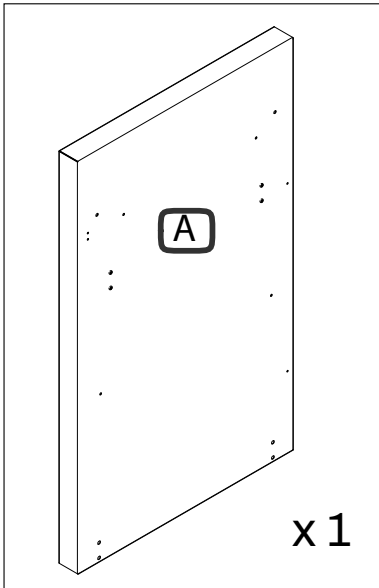

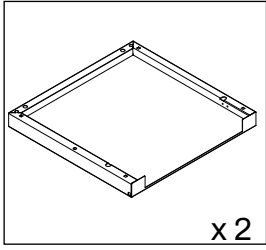

A & B

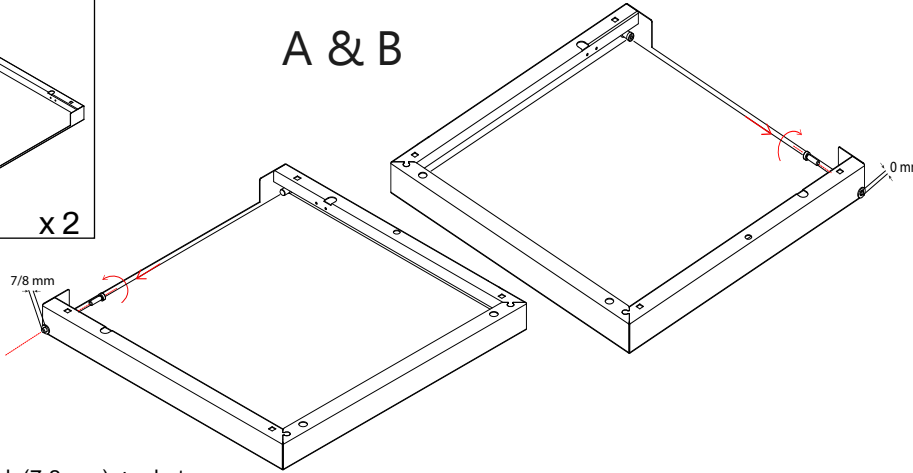

EN Leave a 0,2 Inch (7-8 mm) gap between the screw and the board.

FR Laisser un écart de 7-8 mm entre la vis et la tablette

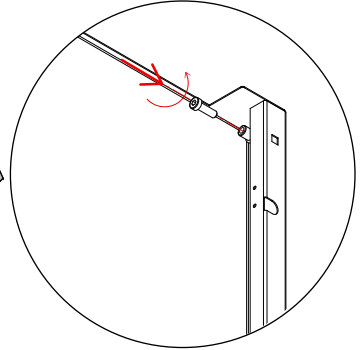
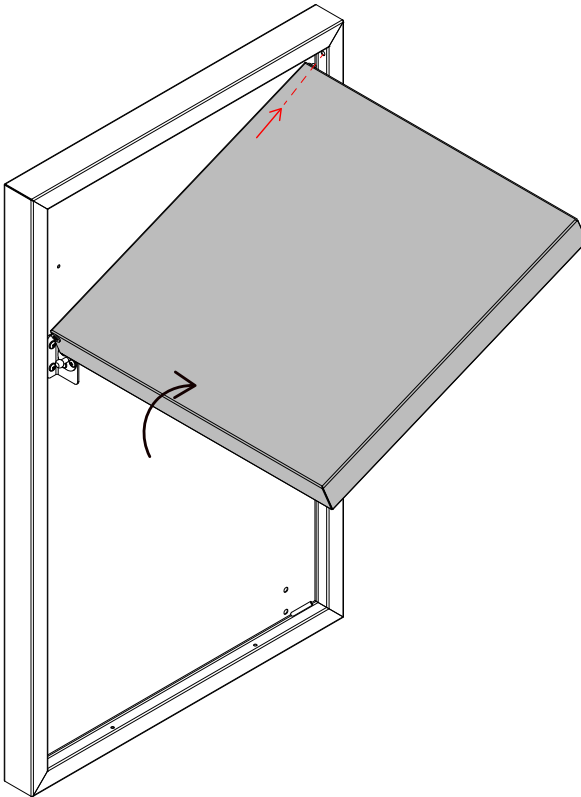

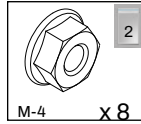
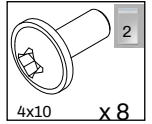
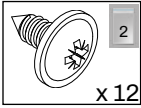
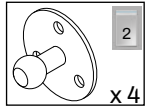
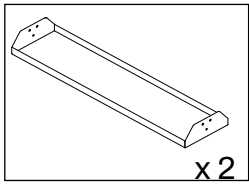

A & B

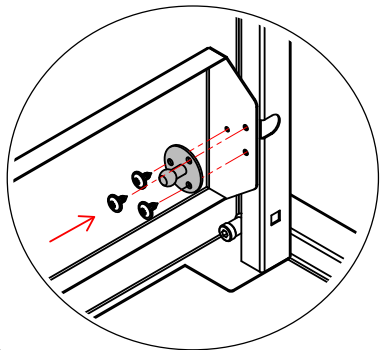
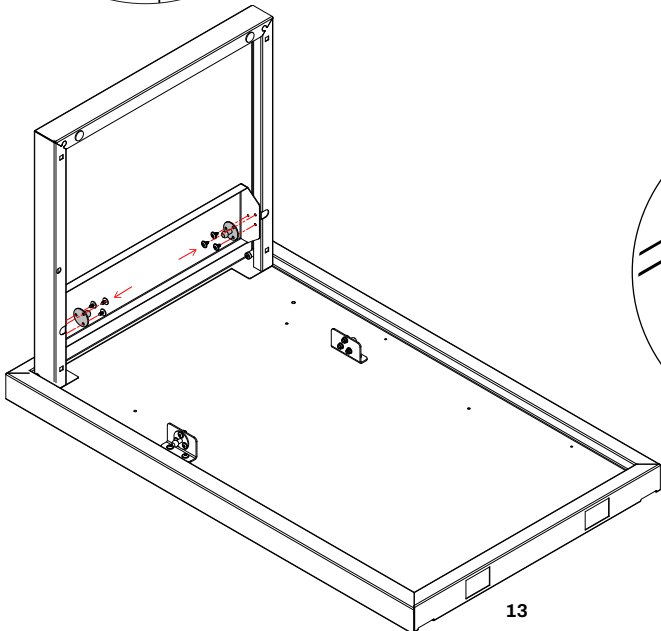
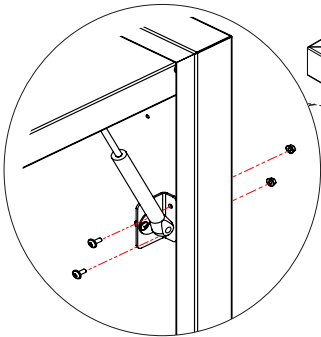
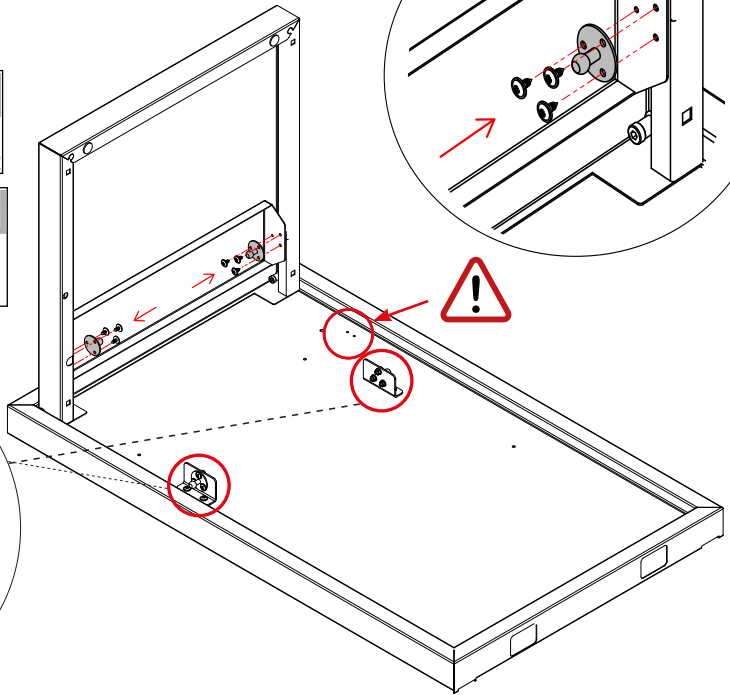
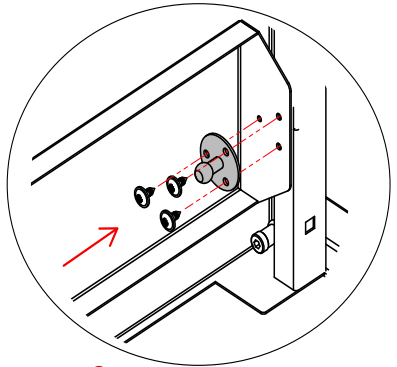

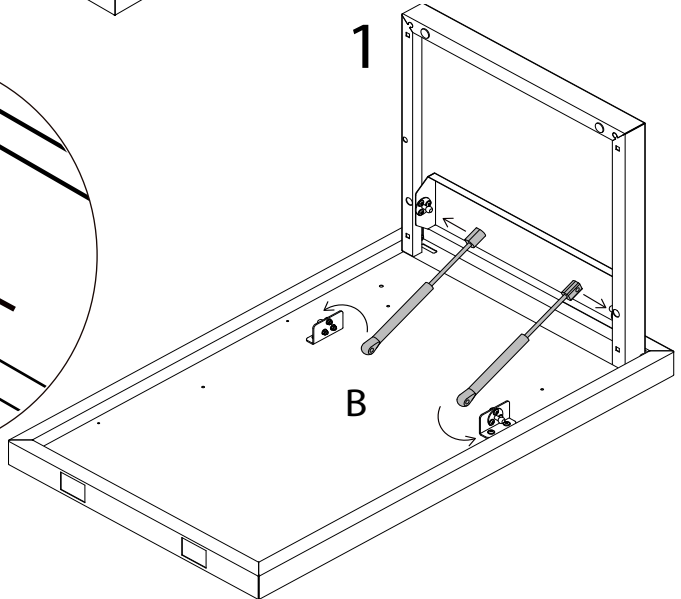
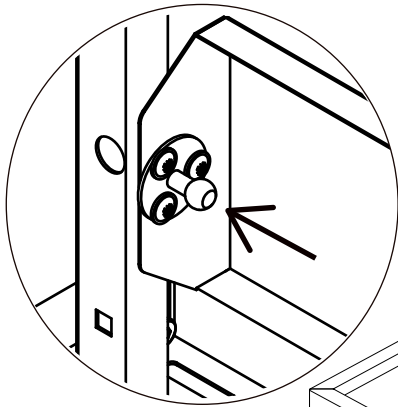
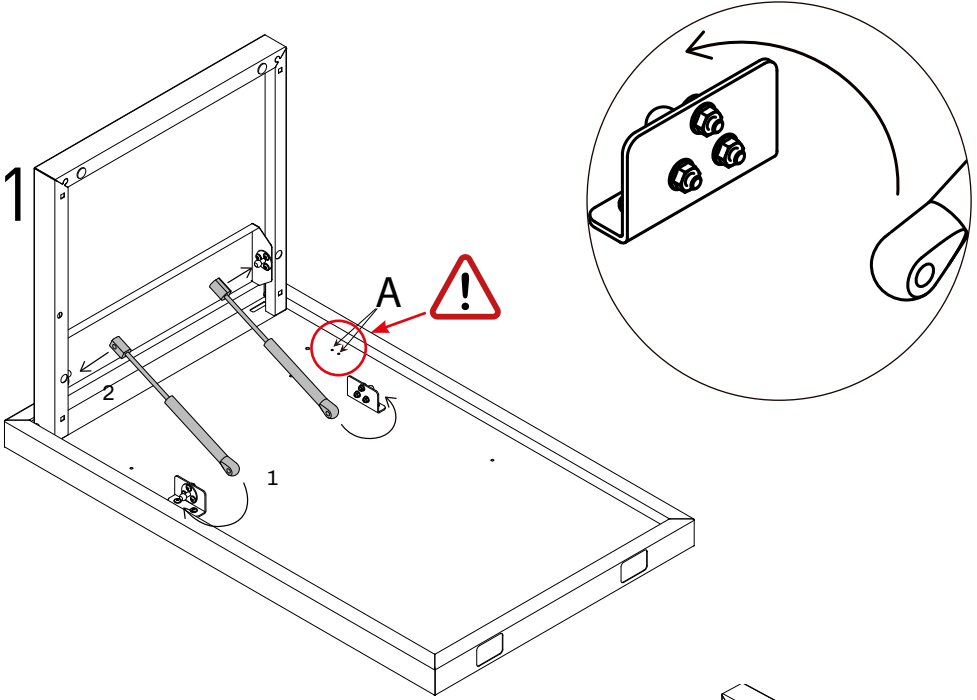
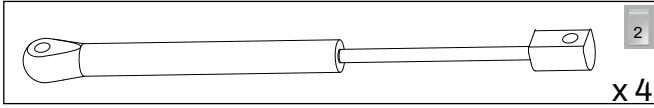

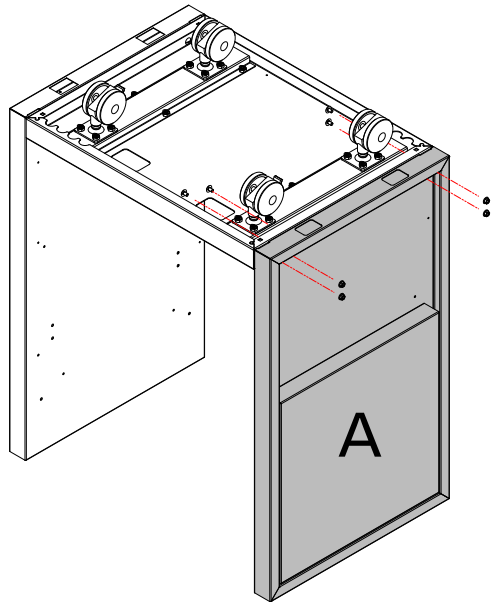
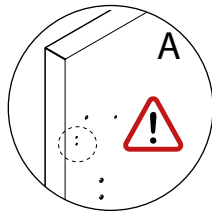
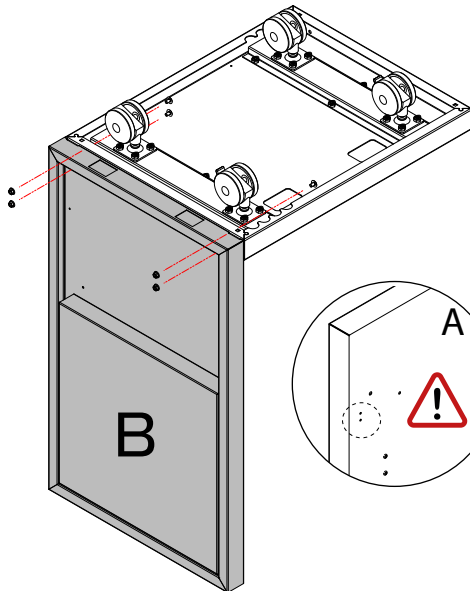
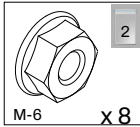
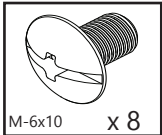
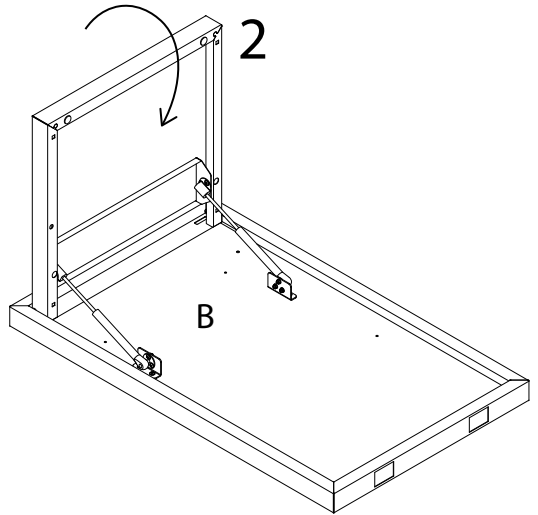
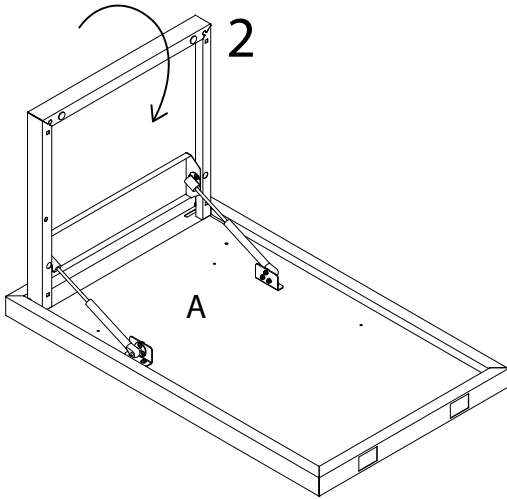

EN Be careful, cutting edges
FR Attention, éléments coupants

EN Lock the griddle cart by engaging the brake on the front wheels.

FR Verrouillez le chariot de la plancha en activant le frein sur les roues avant.

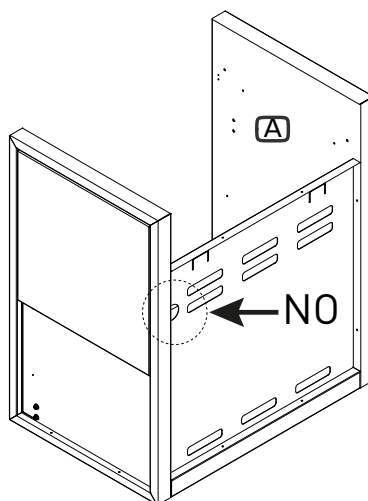
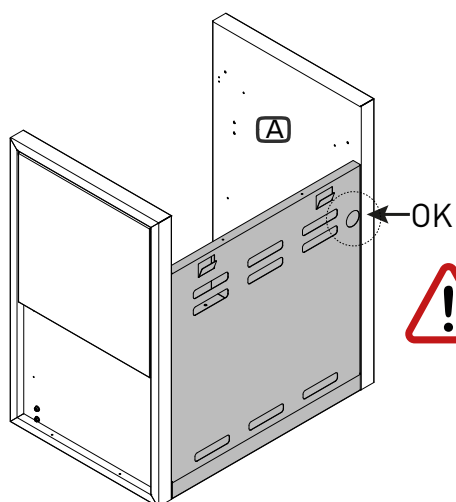
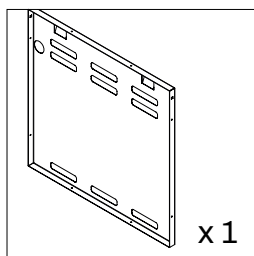
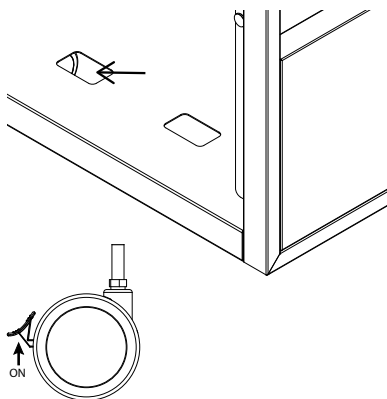

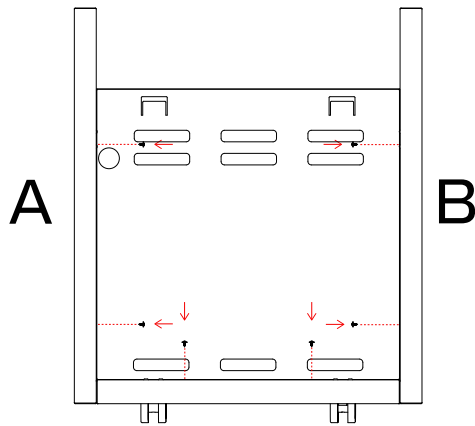
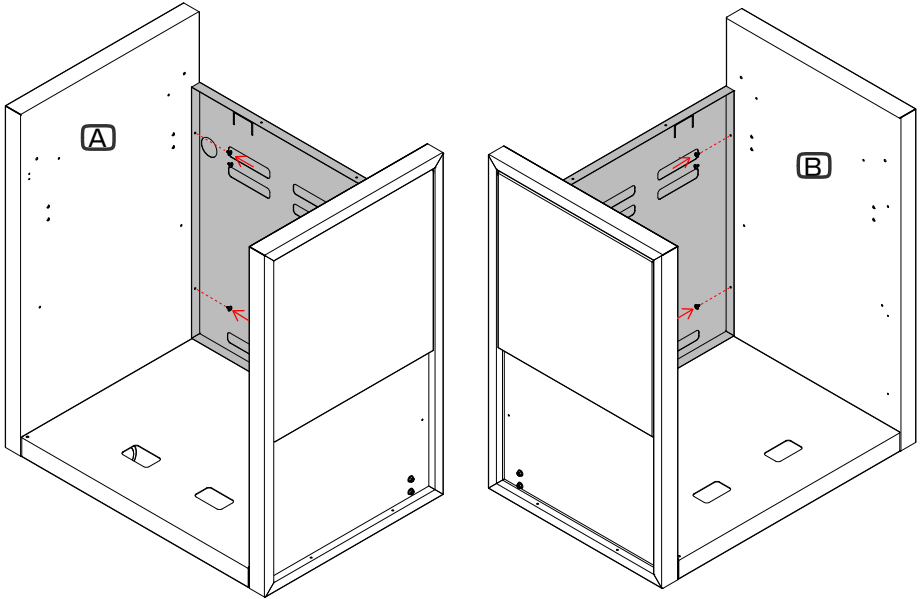
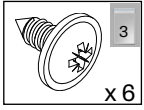

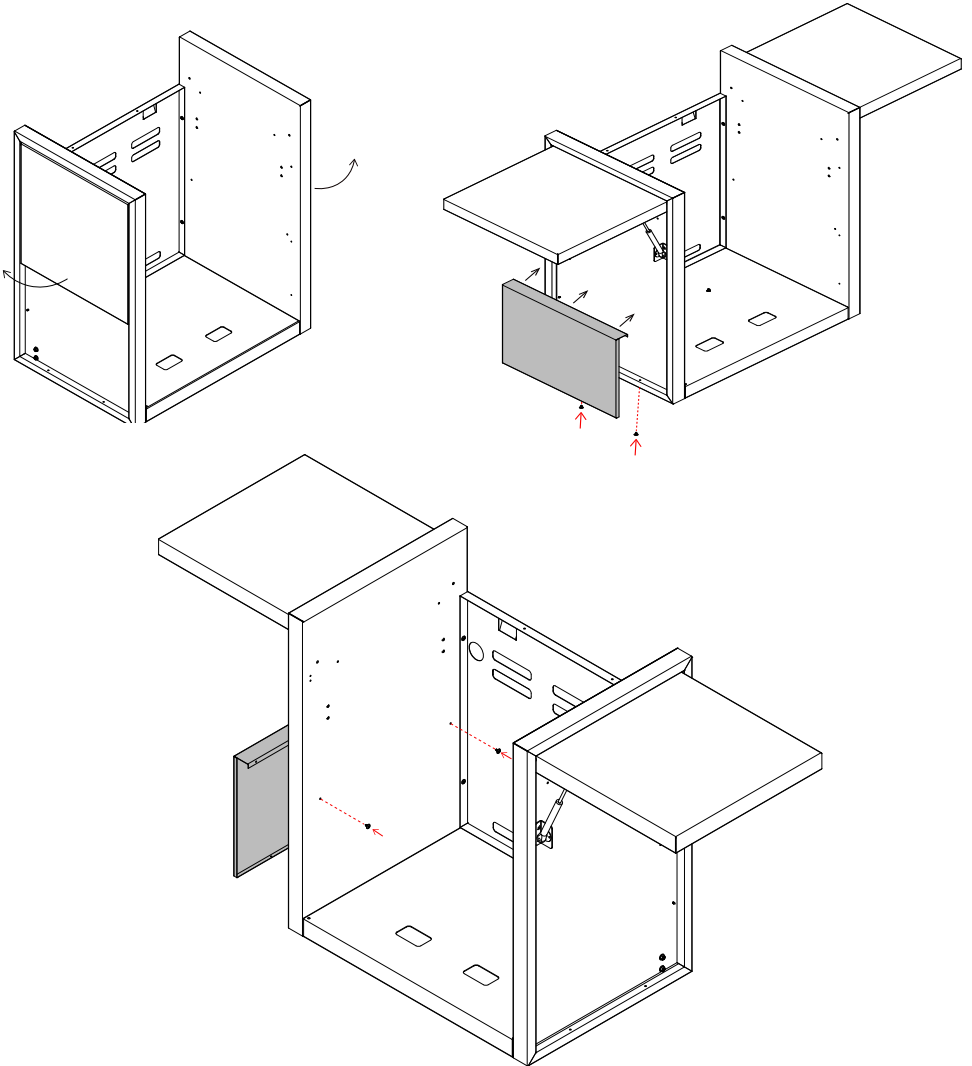
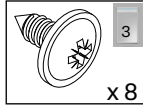
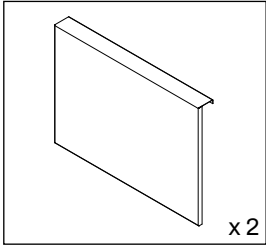

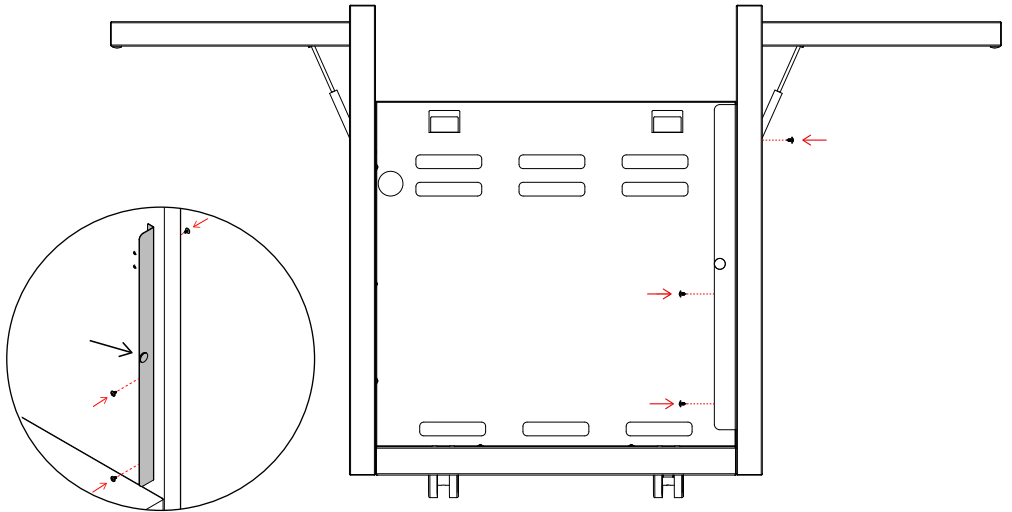
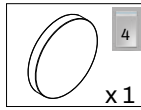
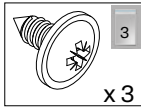
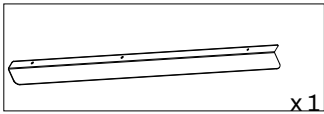
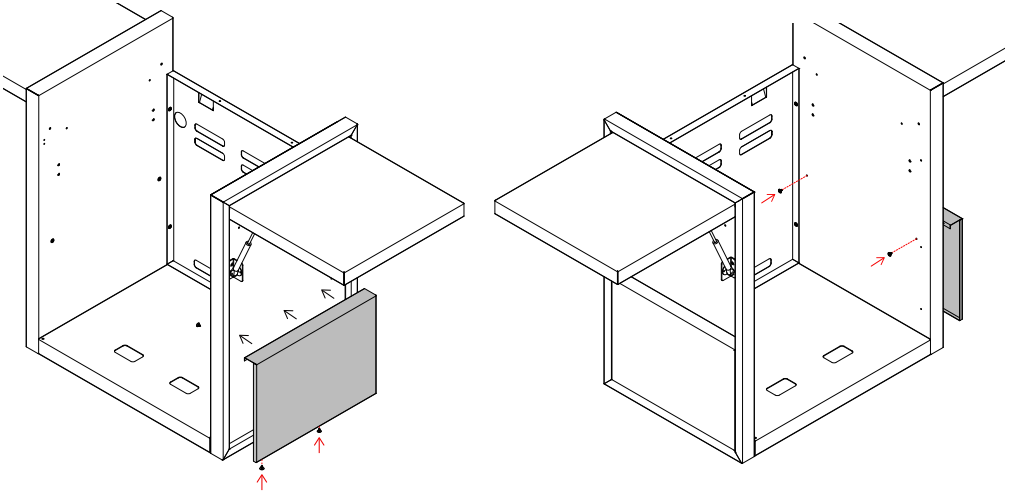

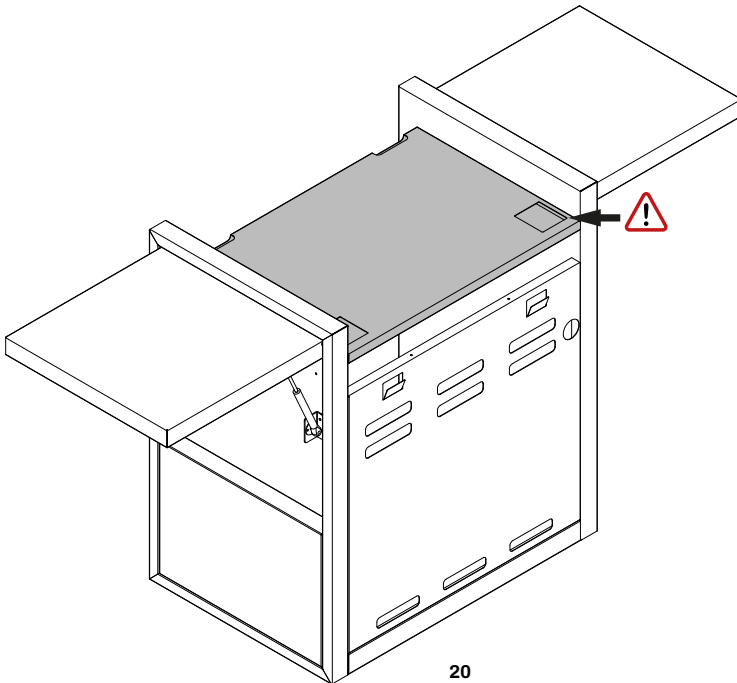
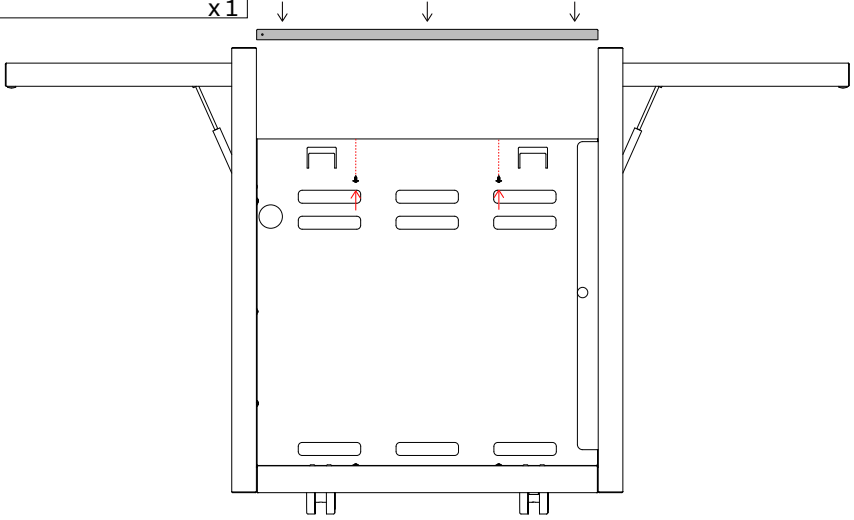
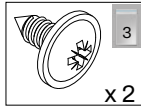
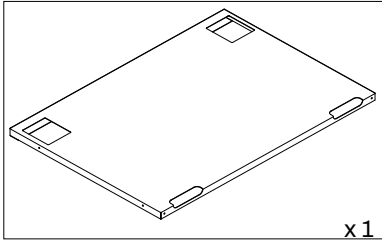

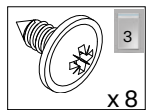
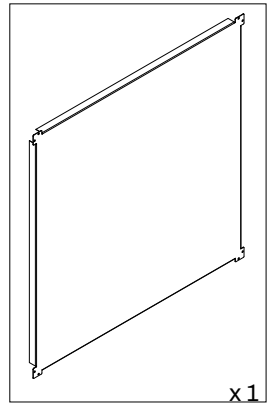
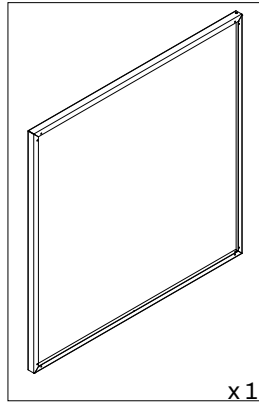
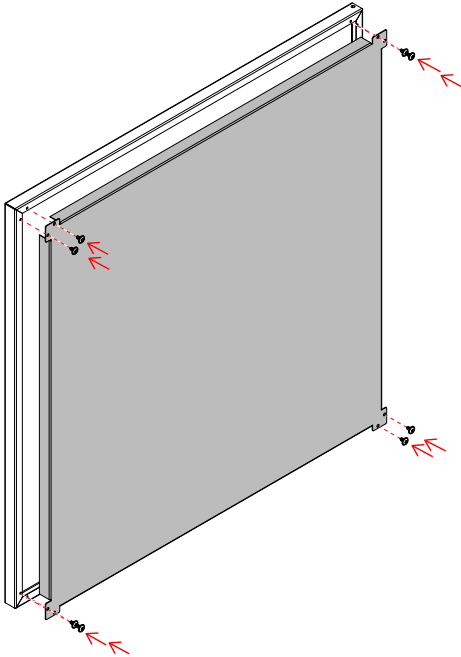
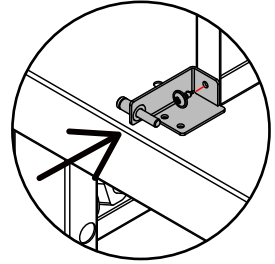
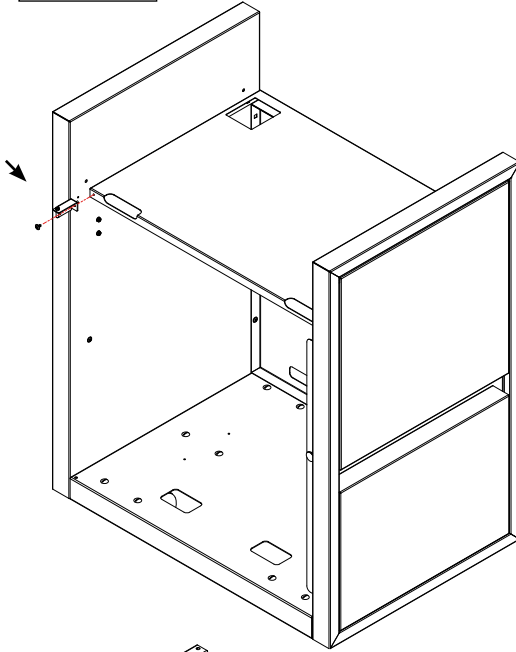
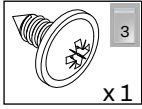
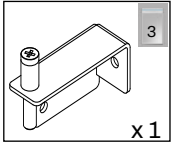

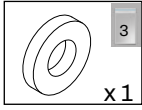
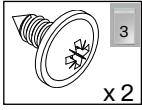

EN Gently lift the tray.
FR Soulever délicatement le plateau.

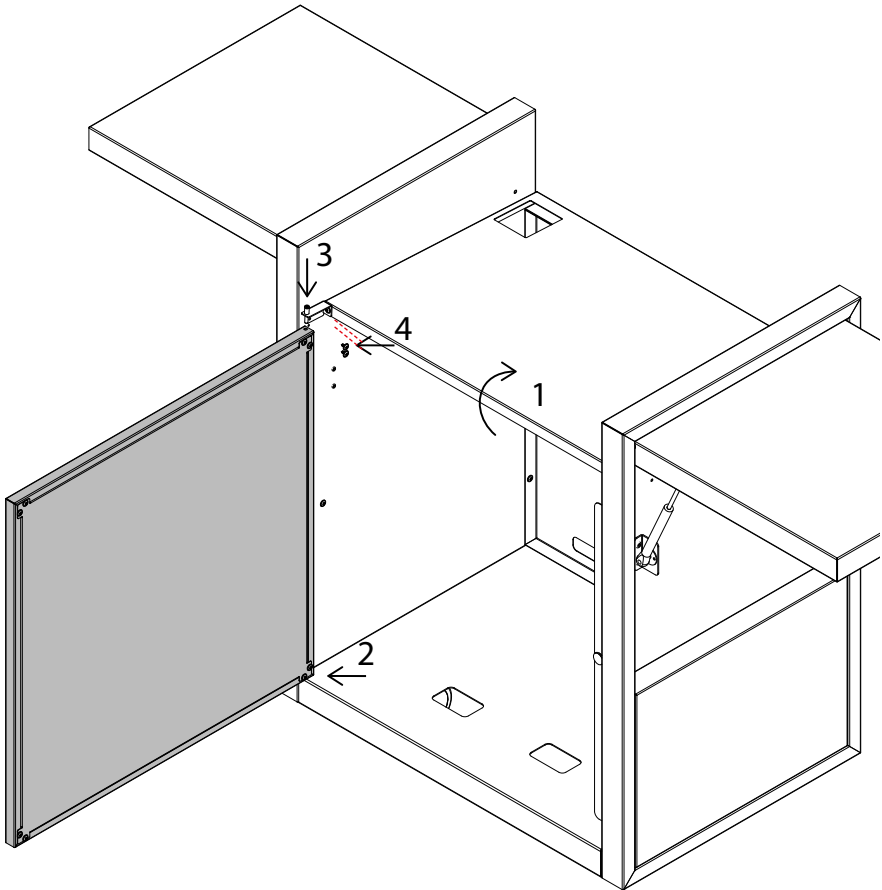
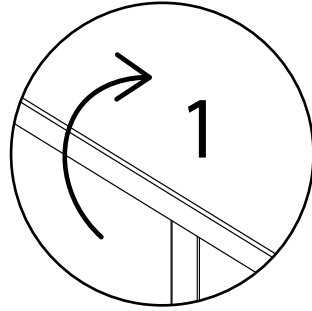

EN Hold the tray up to insert the door, remembering to fit the spacer.

FR Maintenir le plateau levé pour insérer la porte sans oublier de mettre l'entretoise.

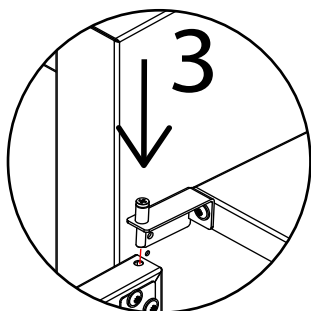
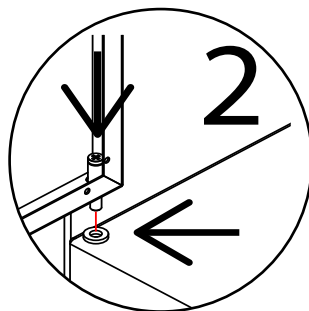

EN Insert the door into the top tray.

FR Insérer la porte dans le plateau supérieur.

EN Gently lower the top tray.

FR Abaisser délicatement le plateau supérieur.

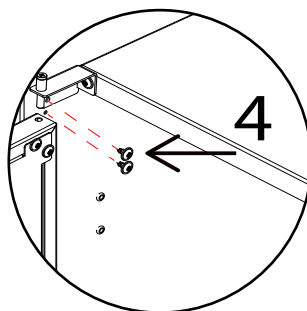

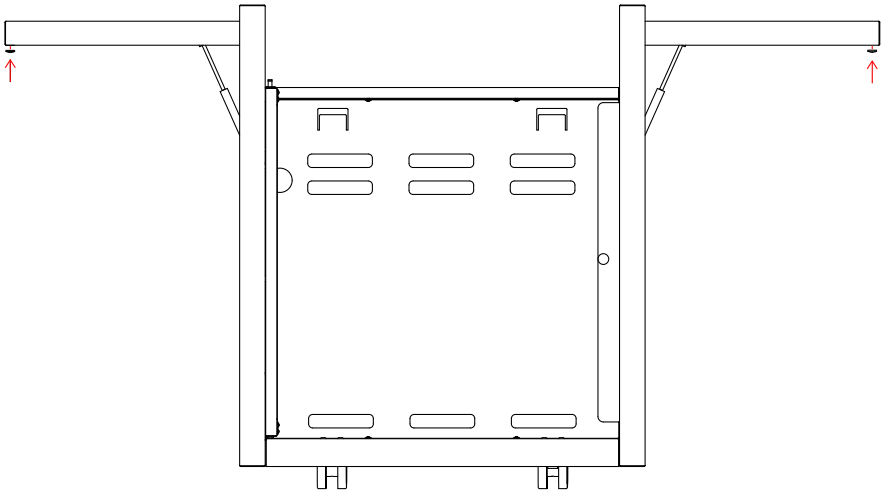
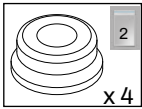
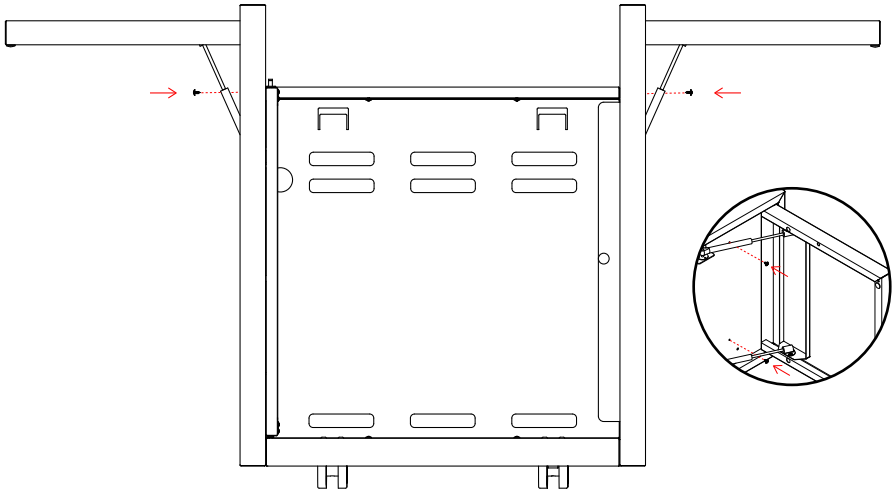
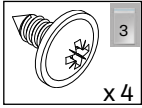

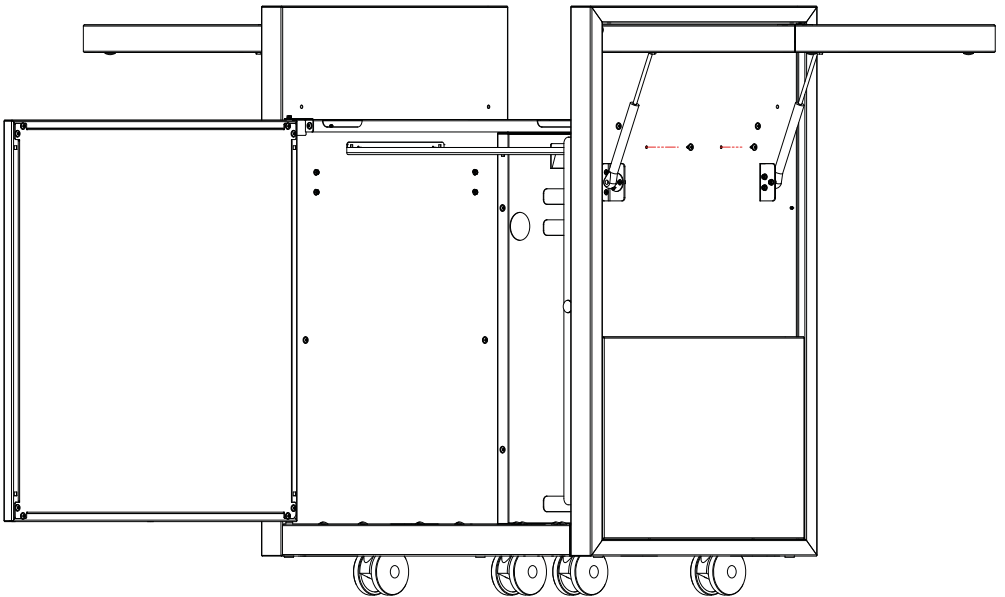
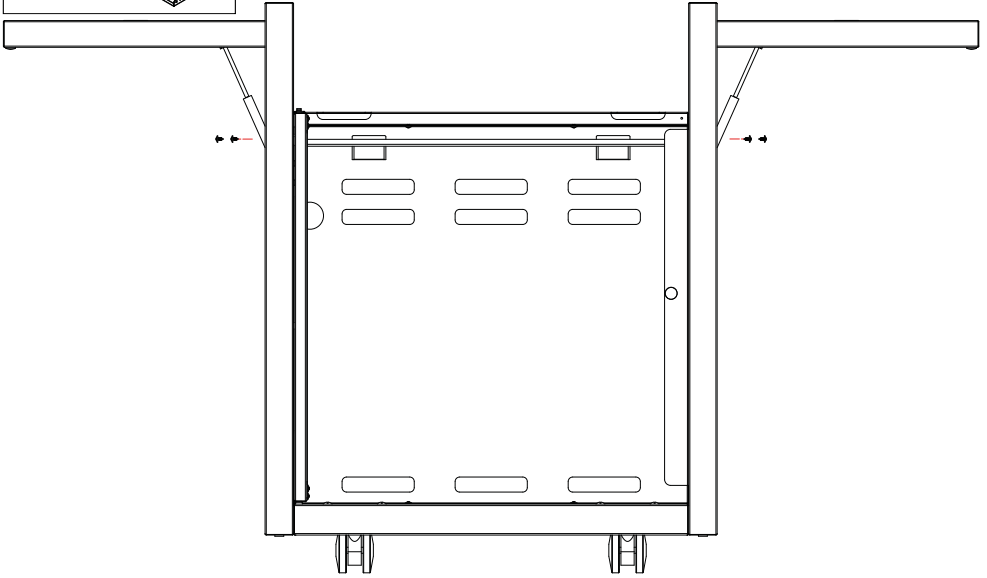
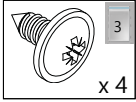
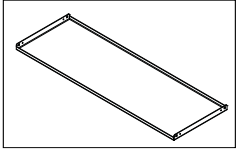

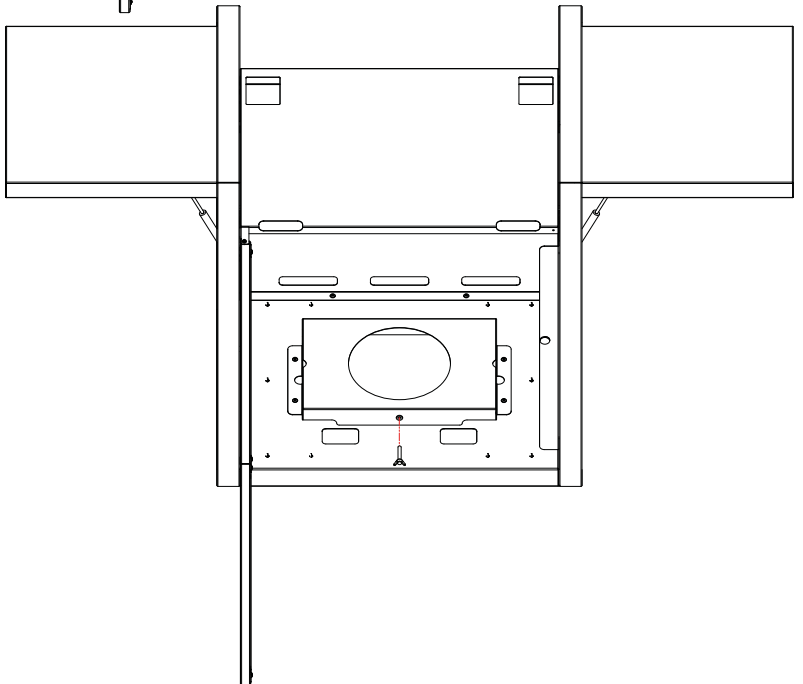
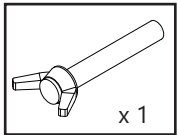
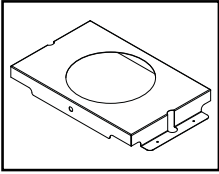
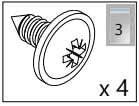
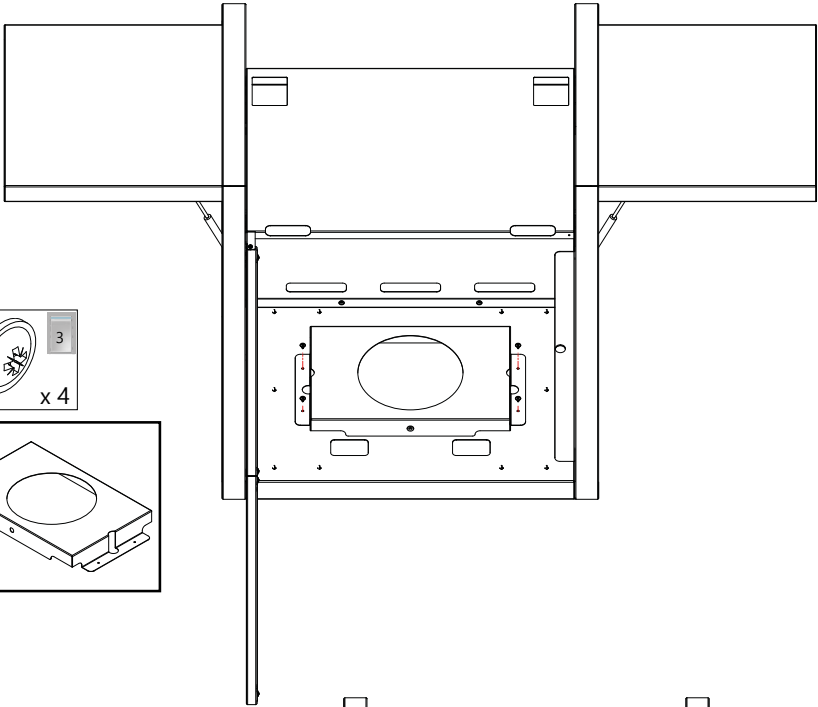

ASSEMBLY - MONTAGE

REMOVE THE PLATE BEFORE PLACING
THE IRON ON THE CART

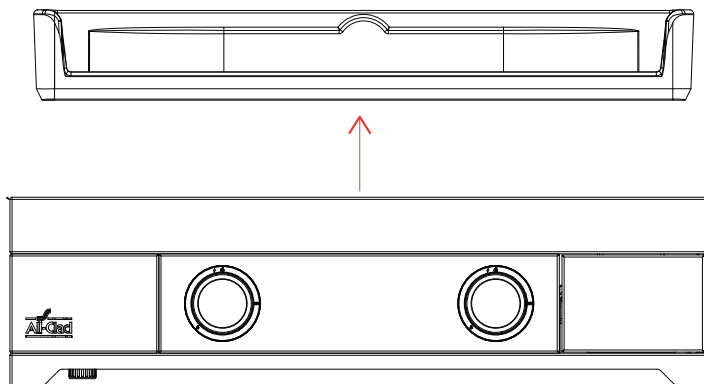

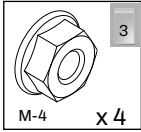
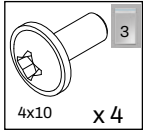

EN Remove the feet of the griddle and then screw the griddle onto the cart.

FR Retirez les pieds réglables de la plancha, puis fixez la plancha au chariot.

FIX THE GRIDDLE MANDATORY

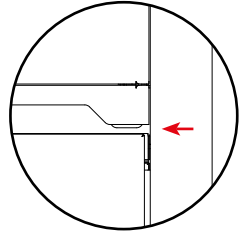

OK

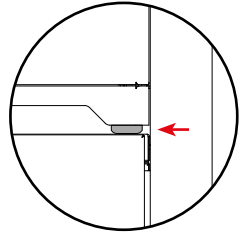

NO

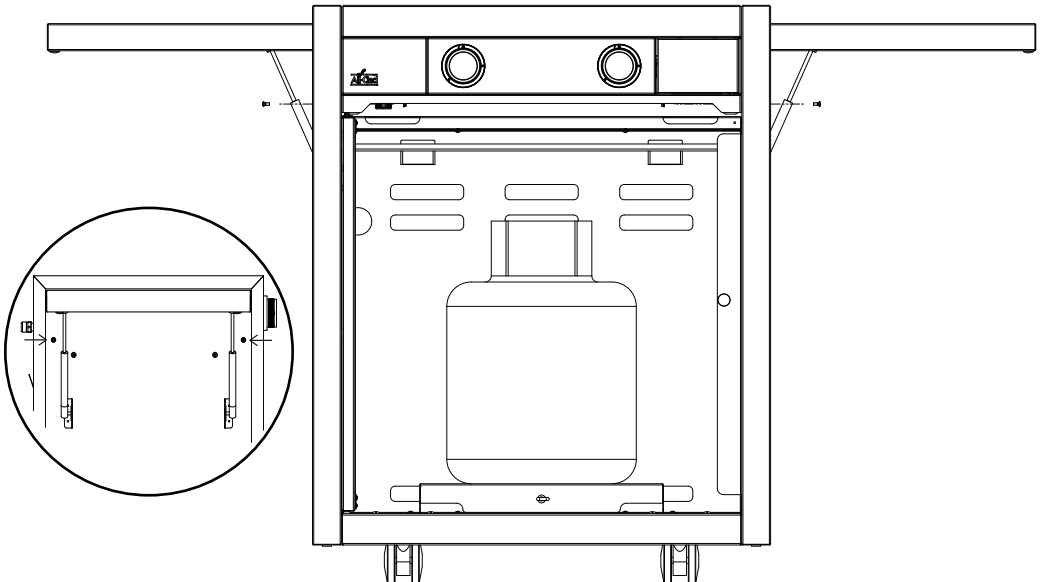

PLACE THE PLATE

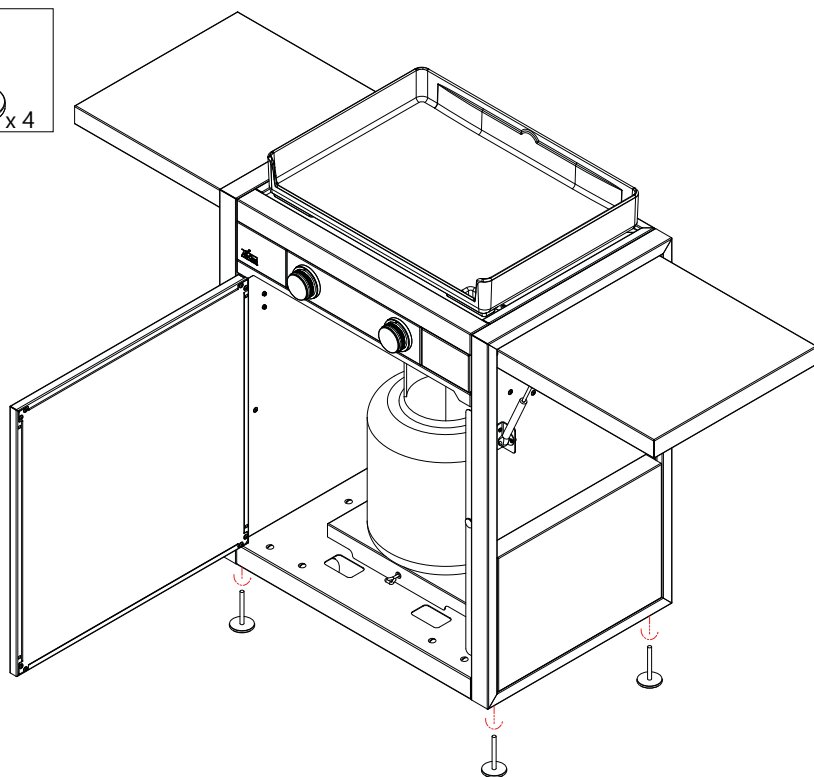
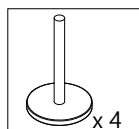
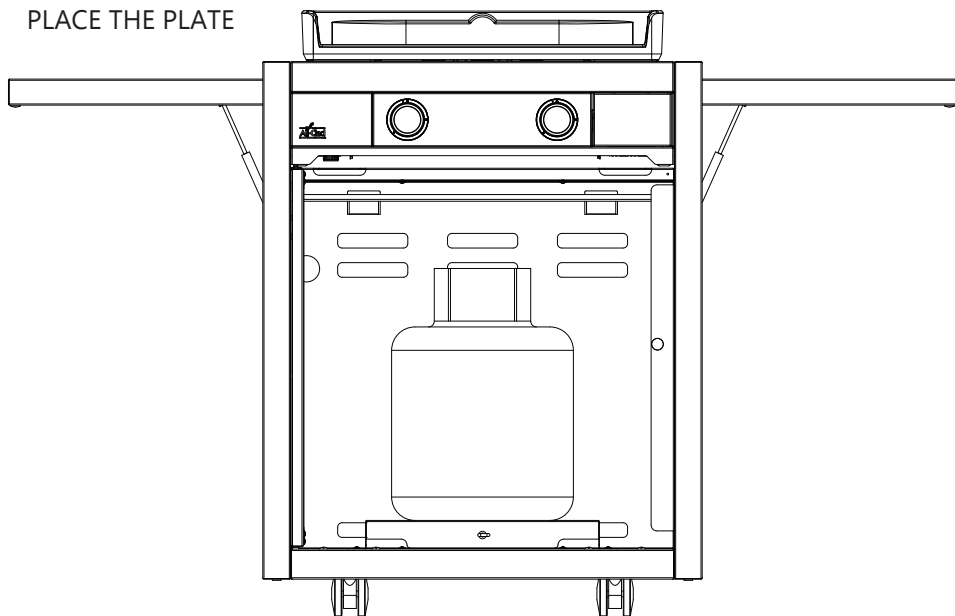

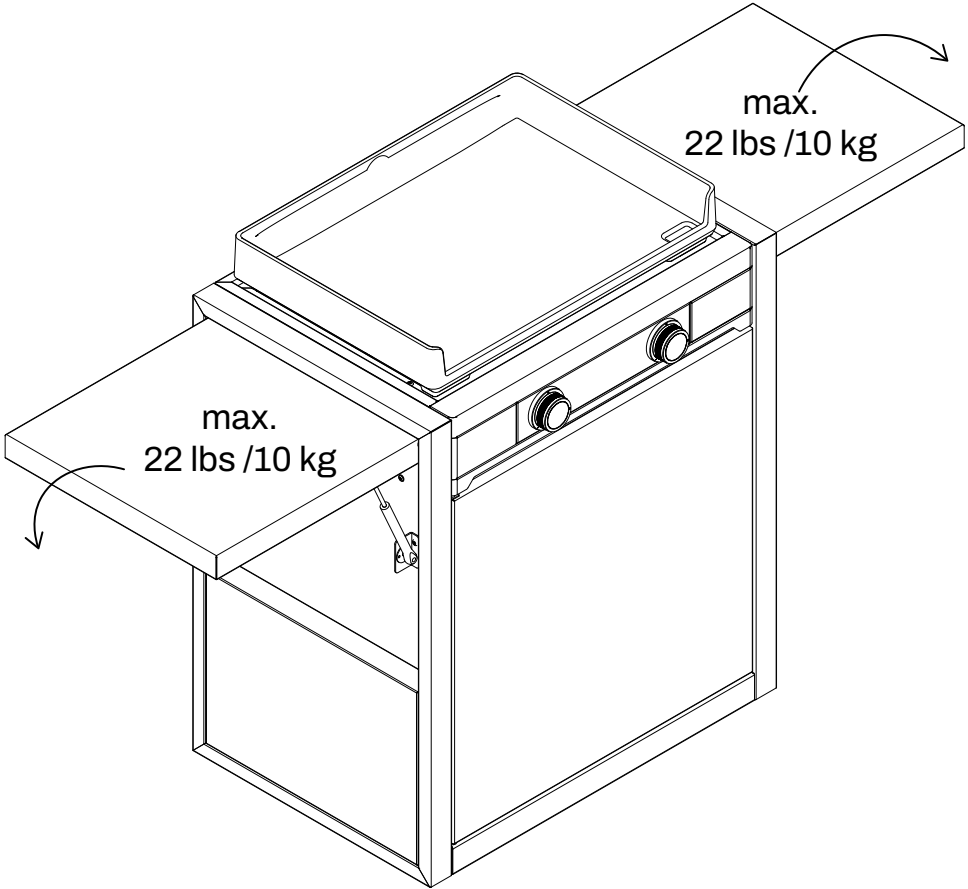

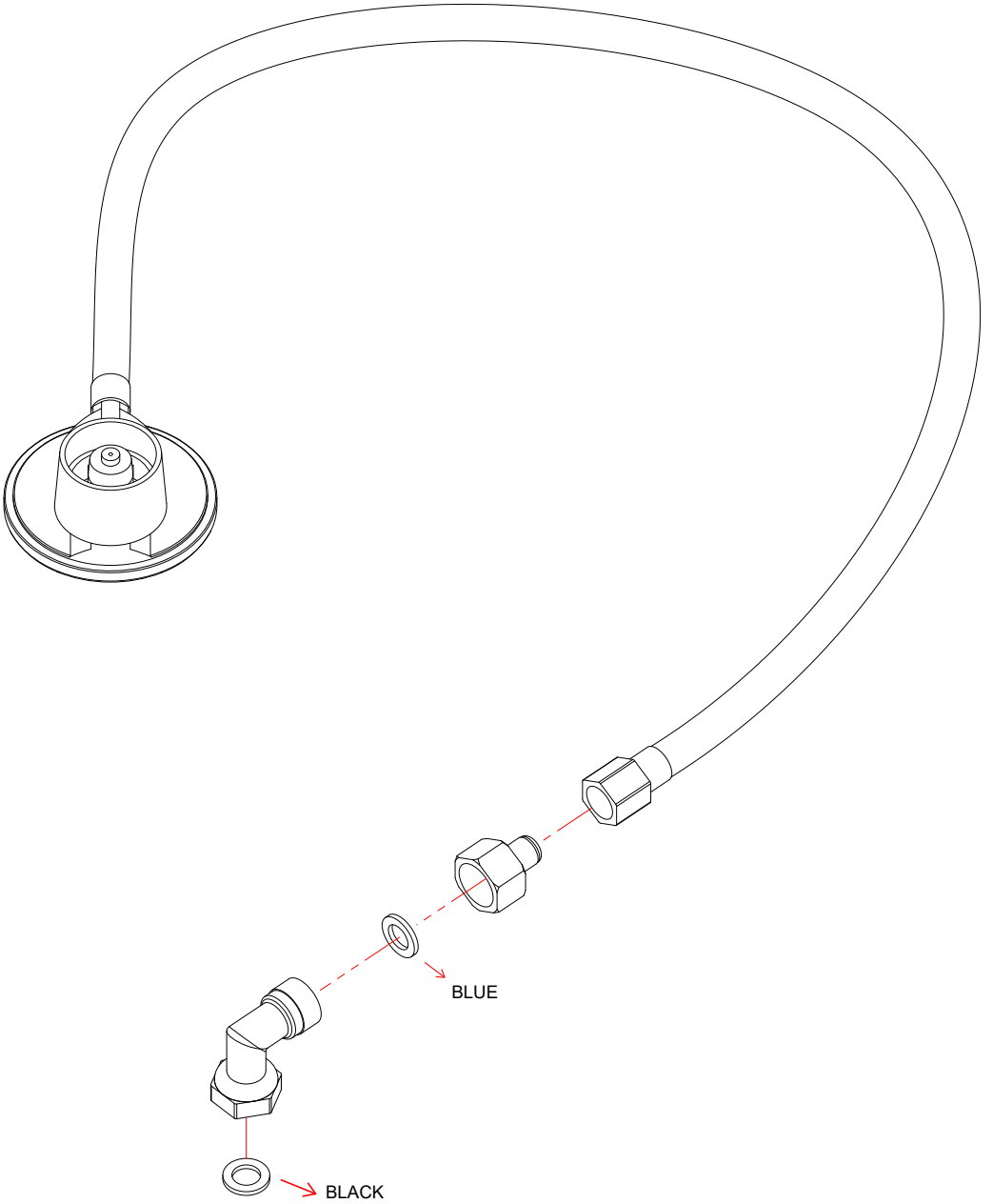

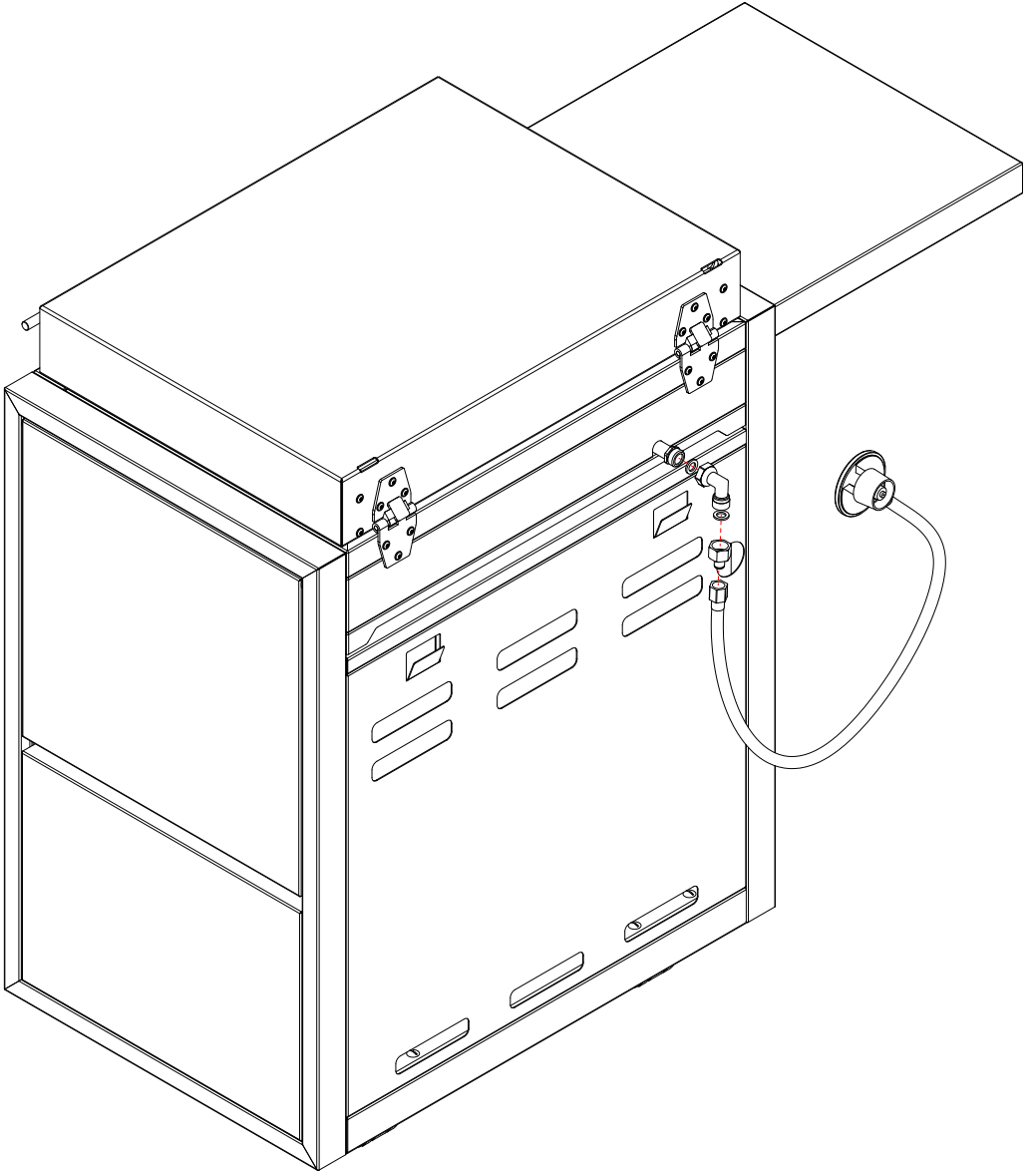

www.all-clad.com

All-Clad Metalcrafters
424 MORGANZA ROAD
CANONSBURG, PA 15317
USA