

# BLACK DIAMOND®

Project Name: \_\_\_\_\_

Location: \_\_\_\_\_

Item #: \_\_\_\_\_

Qty: \_\_\_\_\_

## Black Diamond Undercounter Freezer, 1 Solid Door, 6.3 Cu. Ft. Capacity, in Stainless Steel

### GRUCFZ-27



Elevate your commercial kitchen with the reliable Black Diamond Undercounter Freezer, perfect for space-saving frozen storage in restaurants, cafes, and bars. Built with a durable stainless steel exterior and a painted aluminum interior, this freezer ensures longevity and efficiency. It offers a 6.3 cubic foot capacity and maintains a temperature range of -8° to 0°F. Featuring a single solid stainless steel door, fully automatic controller, and R290 refrigerant, it is designed for ease of use and performance. Maintenance is simple with its automatic defrost system and removable door gasket.

### FEATURES AND CONSTRUCTION

- Offers 6.3 Cu. Ft. of storage capacity for frozen foods and ingredients
- Equipped with a 0.25 horsepower compressor for efficient cooling
- Constructed with durable stainless steel for longevity and easy cleaning
- Maintains a temperature range of -8° to 0°F for optimal food preservation
- Utilizes R290 refrigerant for an eco-friendly operation
- Operates on 115V with a NEMA-5-15P plug for convenience
- Includes one adjustable wire shelf for versatile storage options
- Equipped with four casters for easy mobility and positioning
- Features a user-friendly automatic controller for precise temperature
- Stainless steel doors enhance durability and ease of cleaning

### ELECTRIC

115VV / 60Hz / 1Ph

Cord Length (Inches): 98.40"

Plug Type: NEMA 5-15P

Cord set included

NEMA 5-15P



### 3RD PARTY APPROVALS



### WARRANTY (USA / CANADA)

Two (2) Year Limited Warranty on Parts and Labor, Five (5) Year Warranty on Compressor and Evaporator

Contact us for details at 1.877.368.2797



### STORAGE CAPACITY

- Cubic Feet: 6.3 cu. ft.

### TEMPERATURE

- Holding Temperature (Fahrenheit): -8° - 0°

These models are designed to operate in an environment where temperature and humidity do not exceed 75°F (24°C) and 55% relative humidity



# Black Diamond 1 Door Undercounter Freezer

GRUCFZ-27

FRONT

SIDE

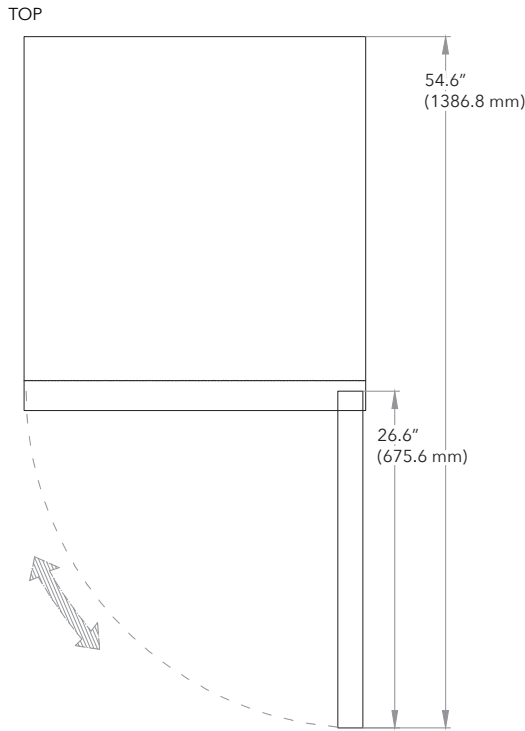
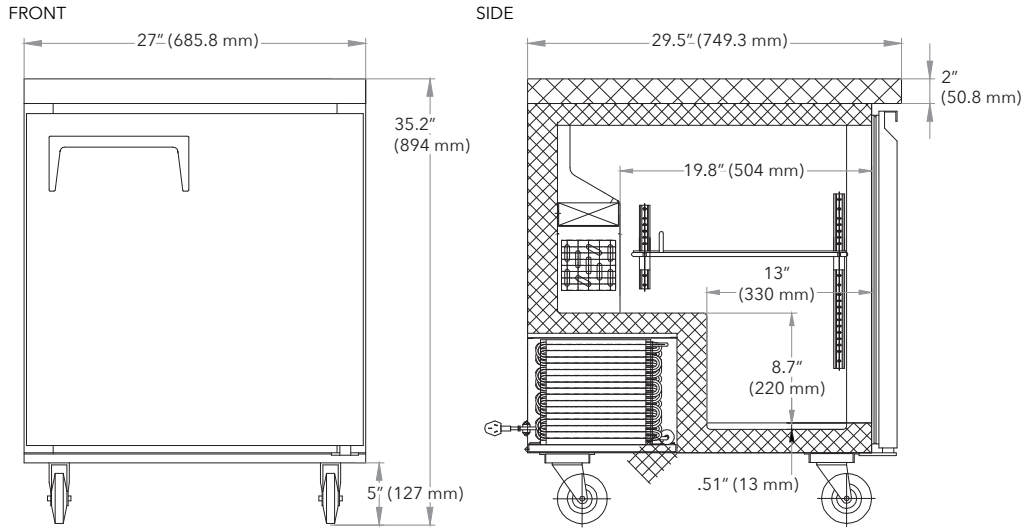

TOP

## Undercounter

Doors	Shelves	Amps	HP	Refrigerant	Assembled Dimensions (in)	Item Weight (lbs)	Shipping Weight (lbs)
1	1	3.6A	1/5	R290	27.00" x 29.50" x 35.20"	158.8	202.0

Due to periodic changes in designs, methods, procedures, policies and regulations, the specifications contained in this document are subject to change without notice. While we exercise good faith efforts to provide information that is accurate, we are not responsible for errors or omissions in information provided or conclusions reached as a result of using the specifications. By using the information provided, the user assumes all risks in connection with such use.