



Scout

M5823

 babyletto





hey there,

It's time to bring that dream nursery to life with babyletto.

We are here to help with all the tools and resources you need to design a space that feels like you.

Our babyletto community is important to us so we're always sharing styling tips, ideas to try, and unique inspiration.

Share your style with us at #babyletto



Welcome to the babyletto family

hola,

Ha llegado el momento de crear ese cuarto de bebé soñado gracias a babyletto.

Estamos aquí para ayudar con todas las herramientas y los recursos necesarios para diseñar un espacio adaptado a ti.

Valoramos la importancia de nuestra comunidad babyletto por eso siempre estamos compartiendo consejos de decoración, ideas para probar y una inspiración única.

Comparte tu estilo con nosotros en #babyletto



Te damos la bienvenida a la familia babyletto

bonjour,

Le temps est venu de créer la chambre de bébé de vos rêves avec babyletto.

Nous sommes ici pour vous aider en vous procurant tous les outils et les ressources dont vous avez besoin pour concevoir un espace qui vous correspond.

Nous accordons une grande importance à la communauté babyletto. Nous veillons à toujours partager des conseils de style, des idées à essayer et des inspirations uniques.

Partagez votre style avec nous en utilisant le mot-clic #babyletto



Bienvenue dans la famille babyletto

getting
started

para
comenzar

pour
commencer

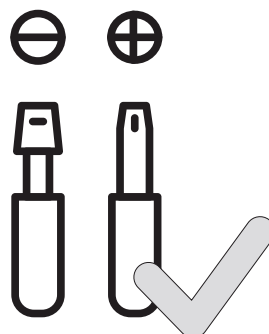
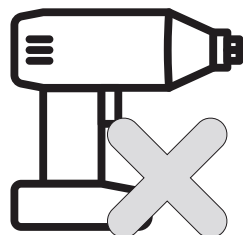
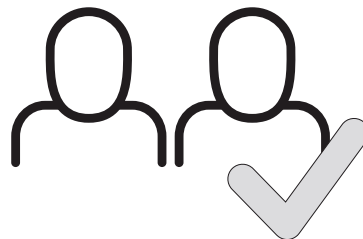
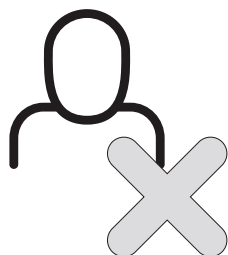

If you need help or have questions, please let us know!

Si necesita ayuda o si tiene preguntas, ¡no deje de contactarnos!

Si vous avez besoin d'aide ou avez des questions, n'hésitez pas à nous le faire savoir!

[BABYLETTO.COM/SUPPORT](https://www.babyletto.com/support)

(323) 282-5163

parts
not to scale

piezas
no a escala

pièces
non dessinées à l'échelle

A-3

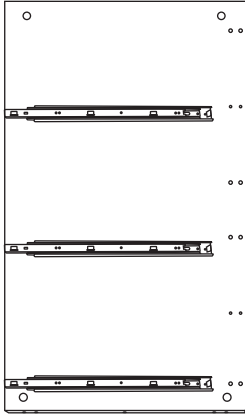

LEFT SIDE PANEL
PANEL LATERAL IZQUIERDO
PANNEAU LATÉRAL GAUCHE

B-3

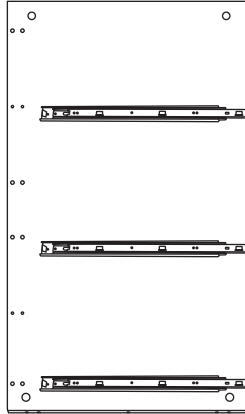

RIGHT SIDE PANEL
PANEL LATERAL DERECHO
PANNEAU LATÉRAL DROIT

C-1



TOP PANEL
PANEL SUPERIOR
DESSUS

D-3

x4

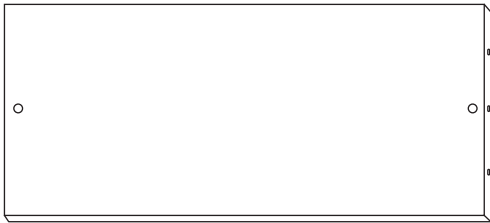

BACK PANEL
PANEL POSTERIOR
PANNEAU ARRIÈRE

E-2

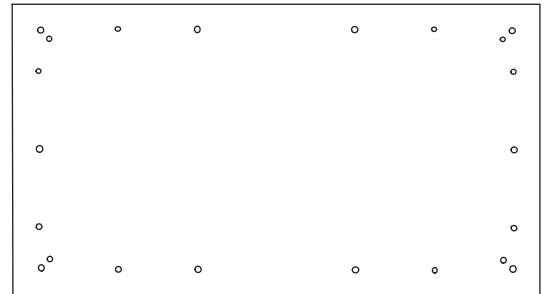

BASE
BASE
BASE

F

x4



FOOT
PIE
PIED

G

x2

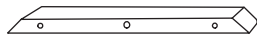

SIDE BOTTOM BAR
BARRA INFERIOR LATERAL
TRAVERSE INFÉRIEURE DE DROITE

H

x2

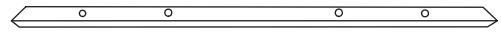

FRONT / BACK BOTTOM BAR
BARRA INFERIOR DELANTERA / TRASERA
TRAVERSE INFÉRIEURE AVANT / ARRIÈRE

J-2
x2



DRAWER FRONT I
FRENTE DE CAJÓN I
FAÇADE DE TIROIR I

K-2

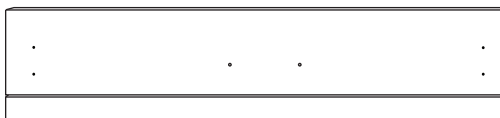

DRAWER FRONT II
FRENTE DE CAJÓN II
FAÇADE DE TIROIR II

L-2
x3



DRAWER BACK
PARTE TRASERA DEL CAJÓN
ARRIÈRE DE TIROIR

M-2
x3



LEFT DRAWER SIDE
LADO DEL CAJÓN IZQUIERDO
CÔTÉ GAUCHE DE TIROIR

N-2
x3



RIGHT DRAWER SIDE
LADO DERECHO DEL CAJÓN
CÔTÉ DROIT DE TIROIR

O
x3



DRAWER BOTTOM
FONDO DE CAJÓN
FOND DE TIROIR

U-1
x2

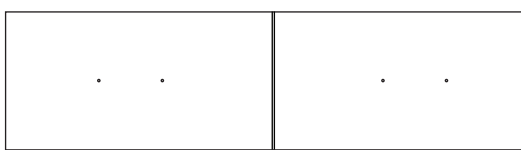

FINISHED DRAWER FRONT I
FRENTE DE CAJÓN TERMINADO I
FAÇADE DE TIROIR DE FINITION I

V-1

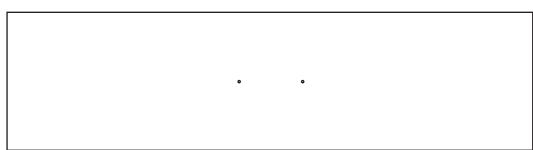

FINISHED DRAWER FRONT II
FRENTE DE CAJÓN TERMINADO II
FAÇADE DE TIROIR DE FINITION II

hardware
actual size

herraje
tamaño real

matériel
taille actuelle

H1

x12

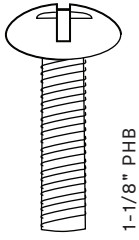

1-1/8" PHB

H2

x12



7/16" PHS

H3

x16



CB

H4

x16



CL

H5

x28

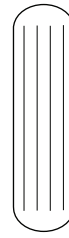

0.8*3 WD

H6

x10

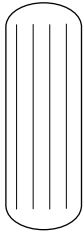

1*3 WD

H8

x10



1-1/4" KB

H9

x5

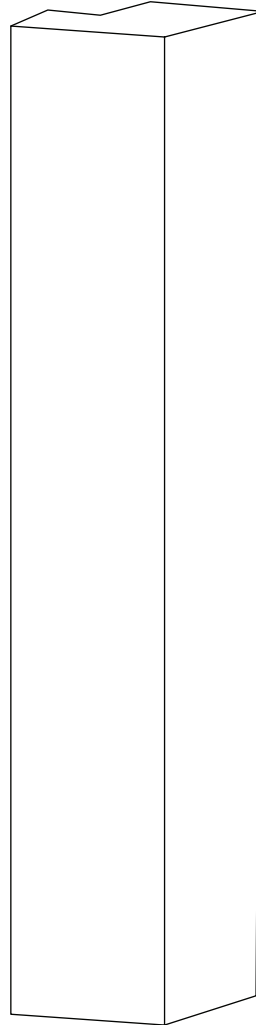

K

H10

x6

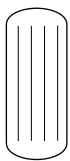

0.8*2 WD

H11

x36

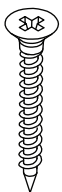

7/8" PHS

assembly
instructions

instrucciones
de ensamblaje

instructions
de montage

1

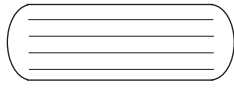

H6
x10

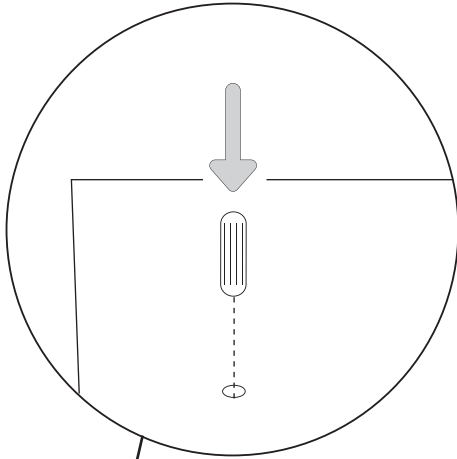

x10

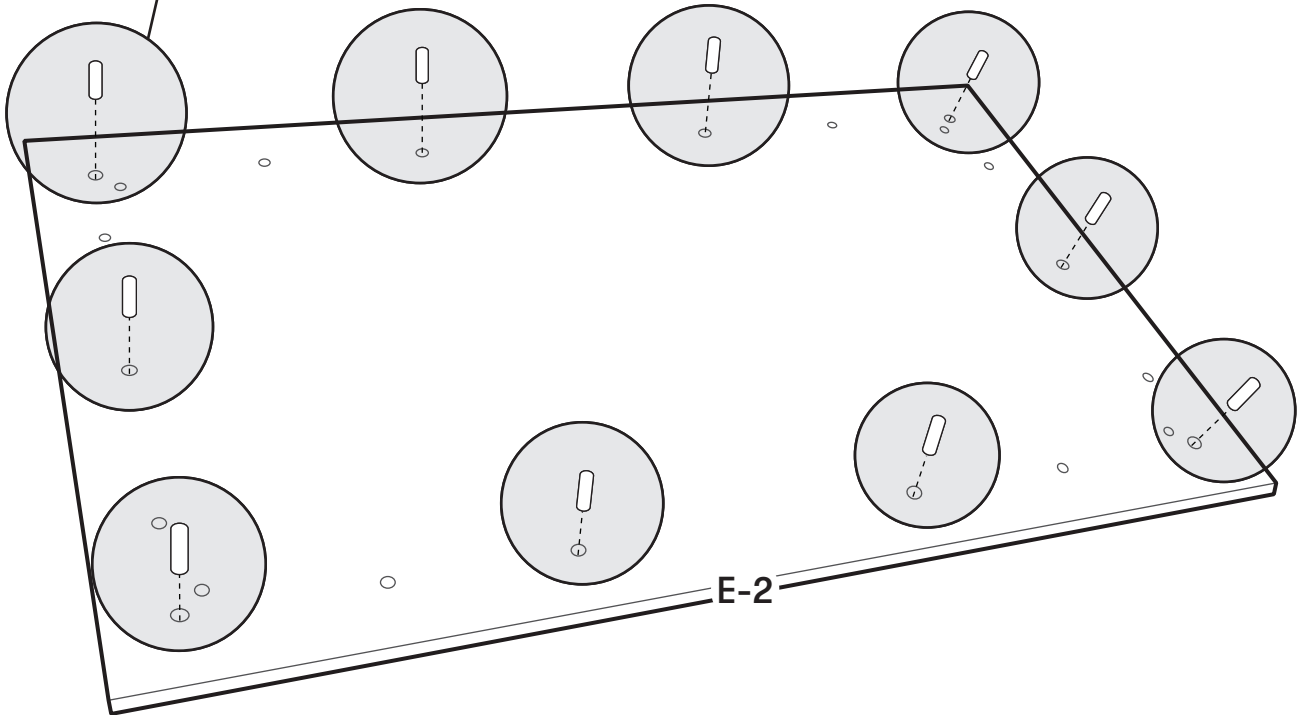

2

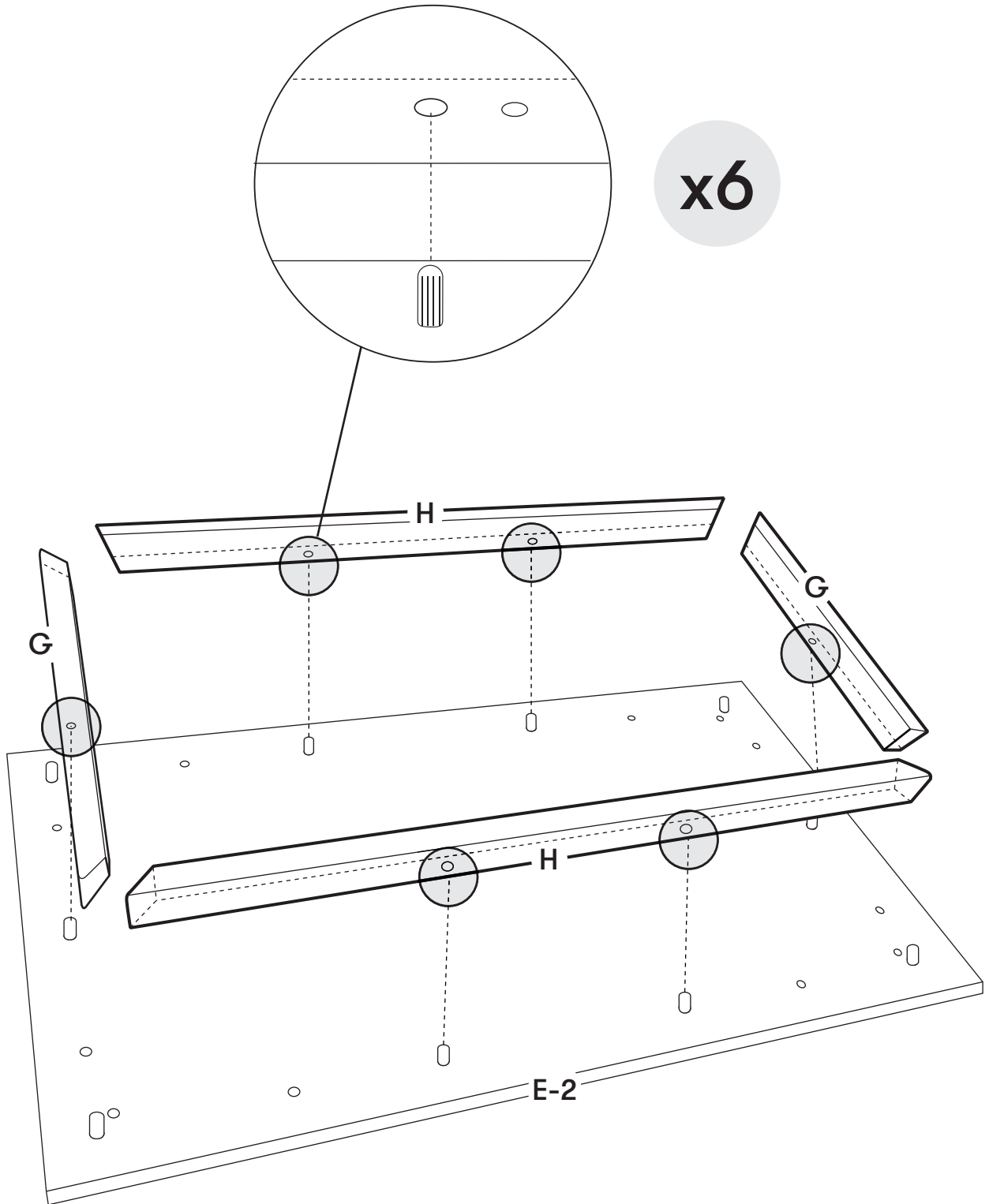

3

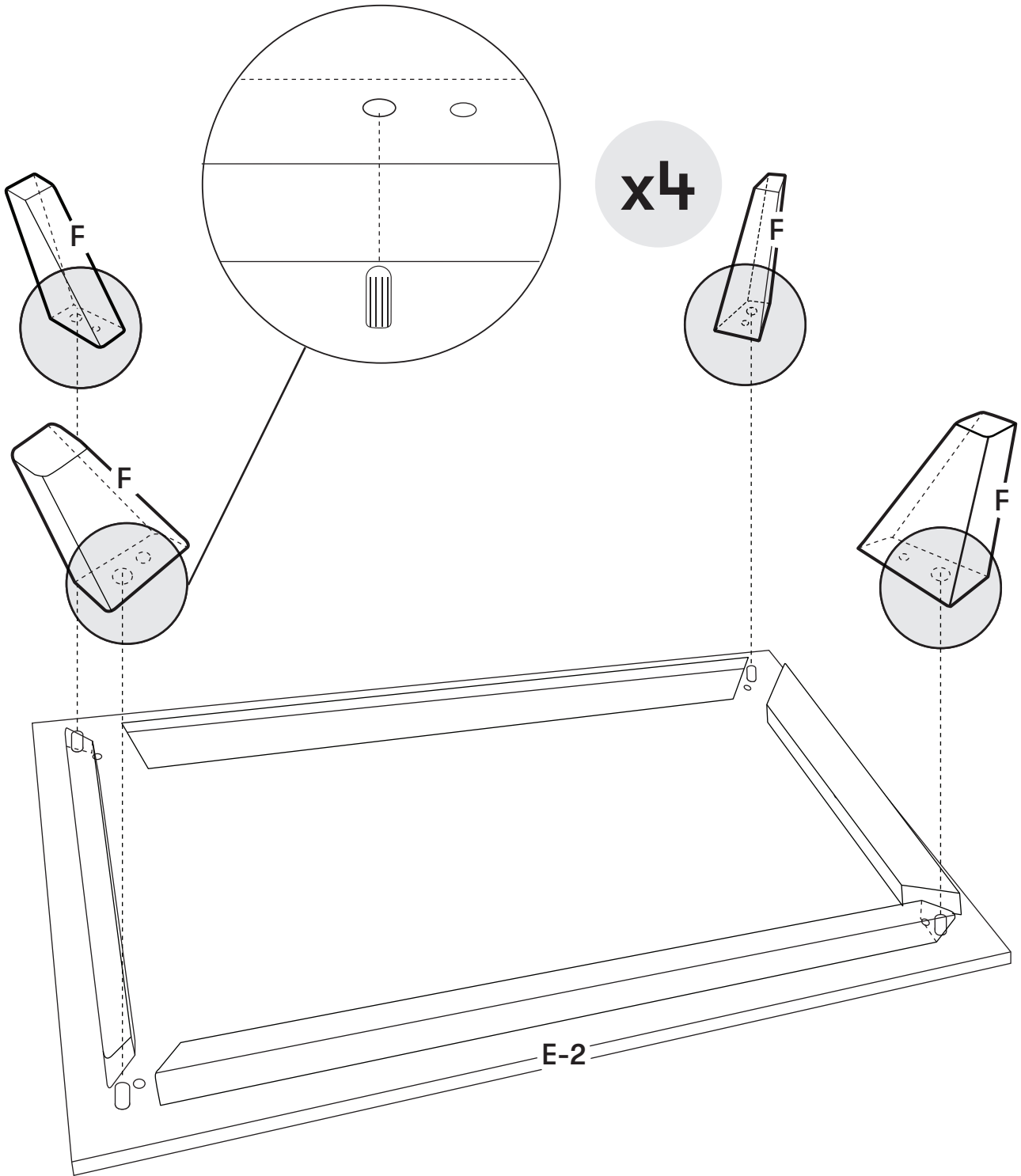

4

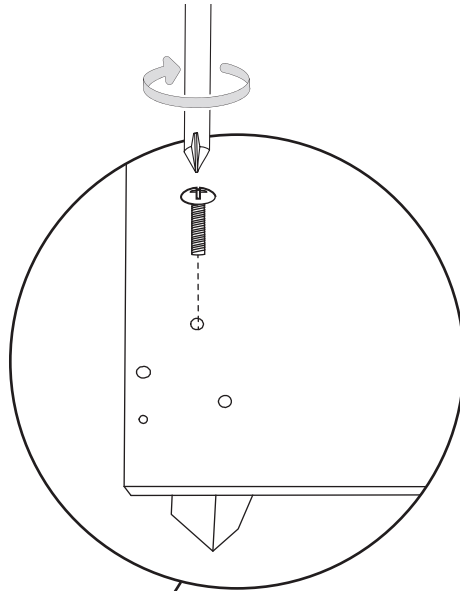
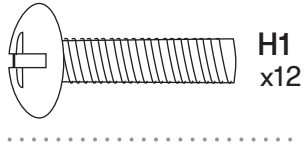

x12

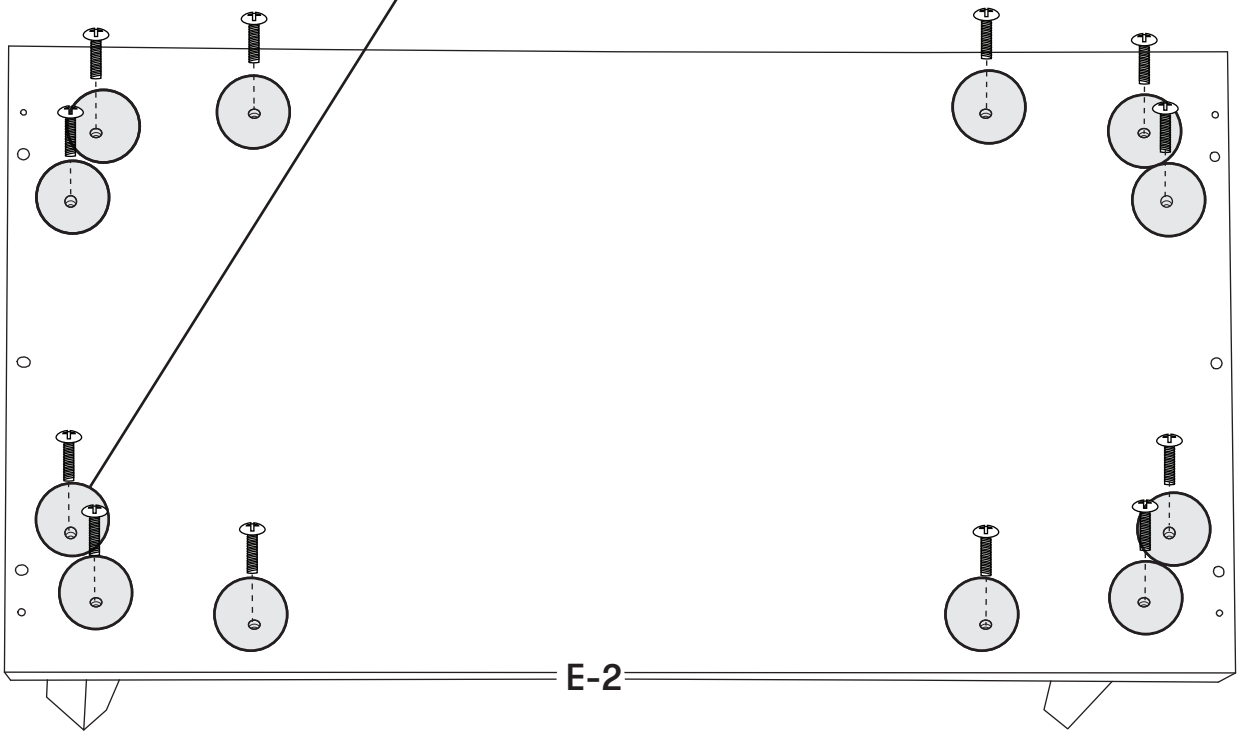

5

H3
x4

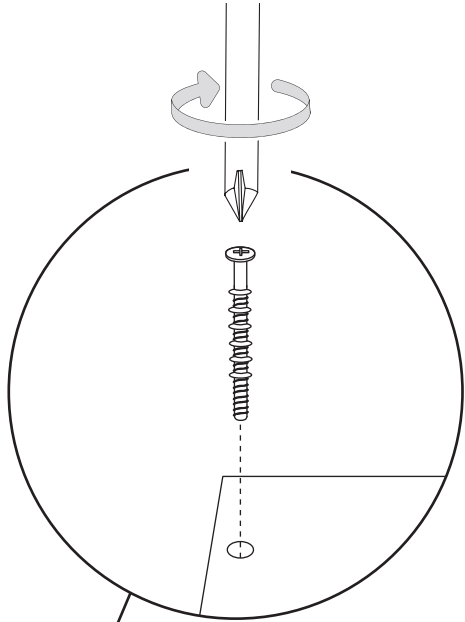

x4

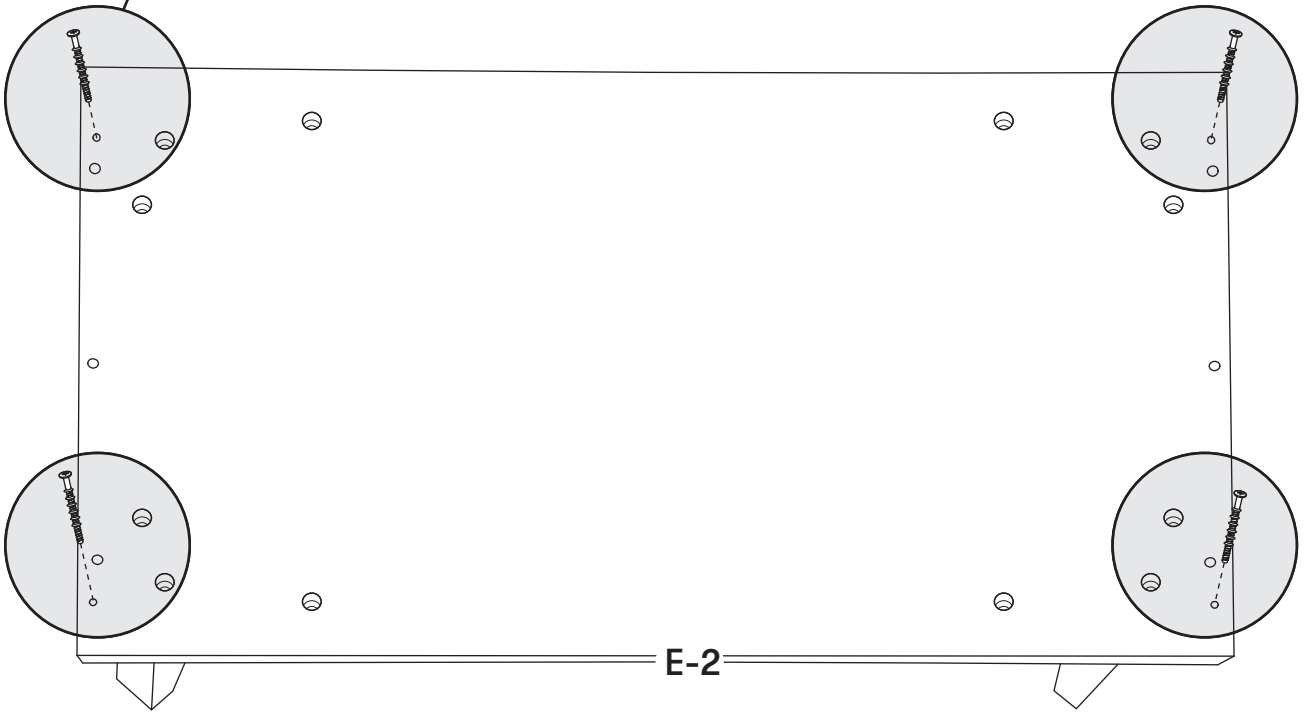
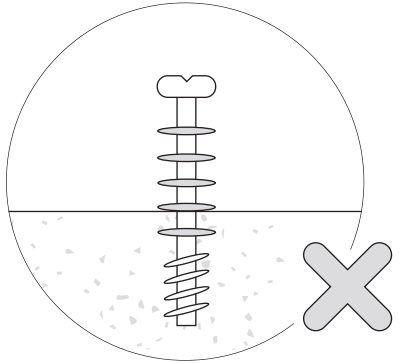
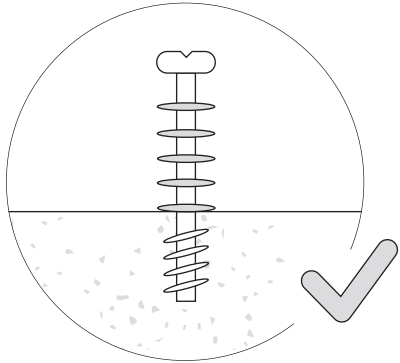

6

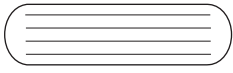

H5
x6

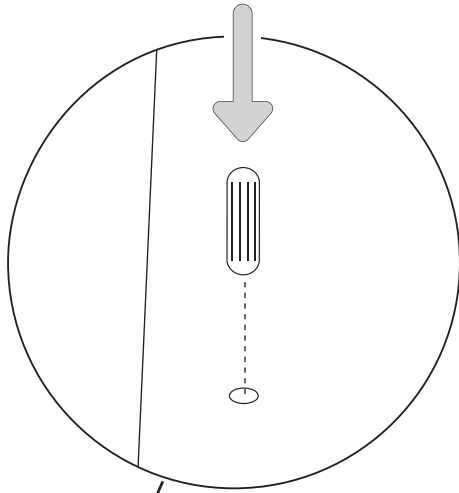

x6

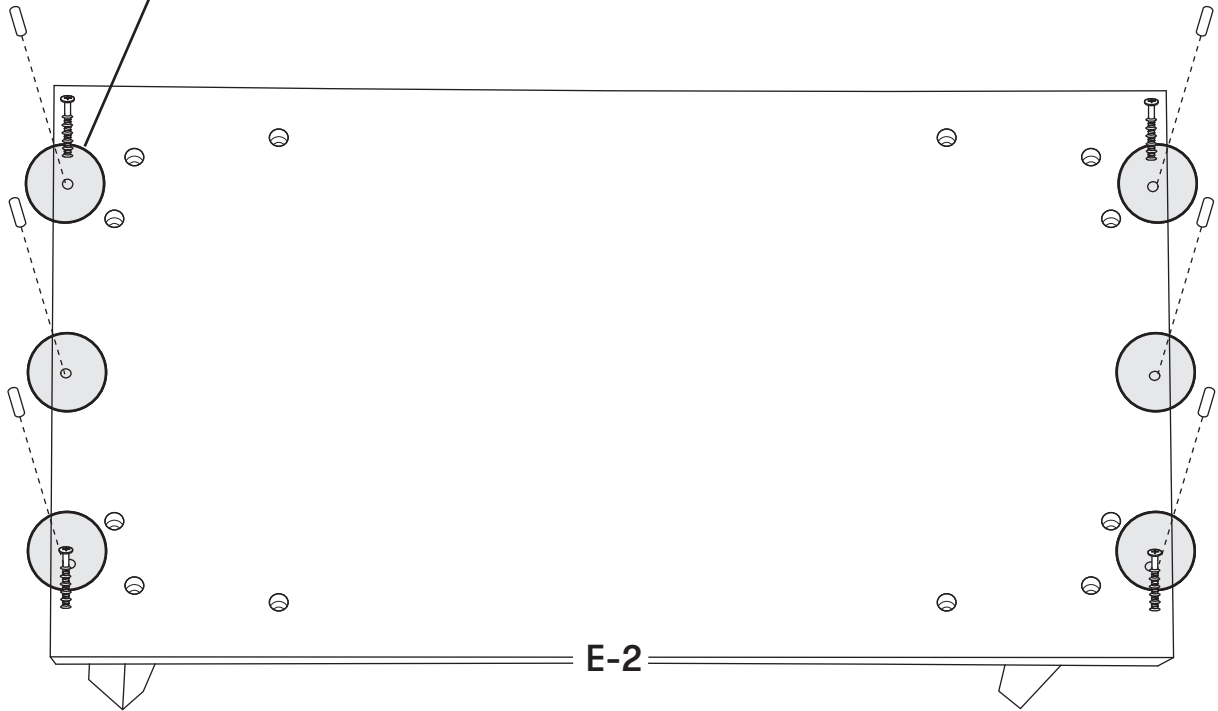

7

H3
x8

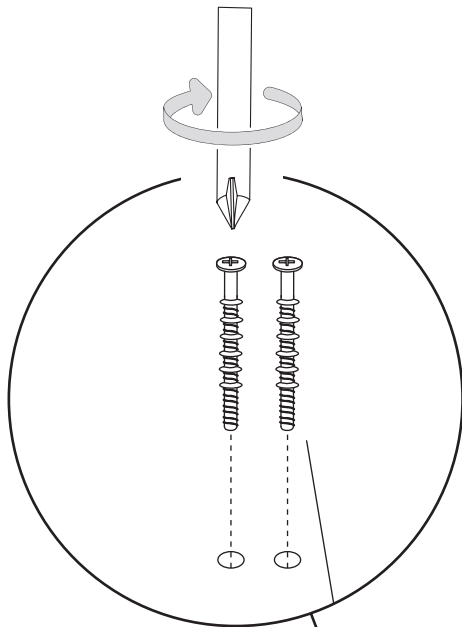

x4

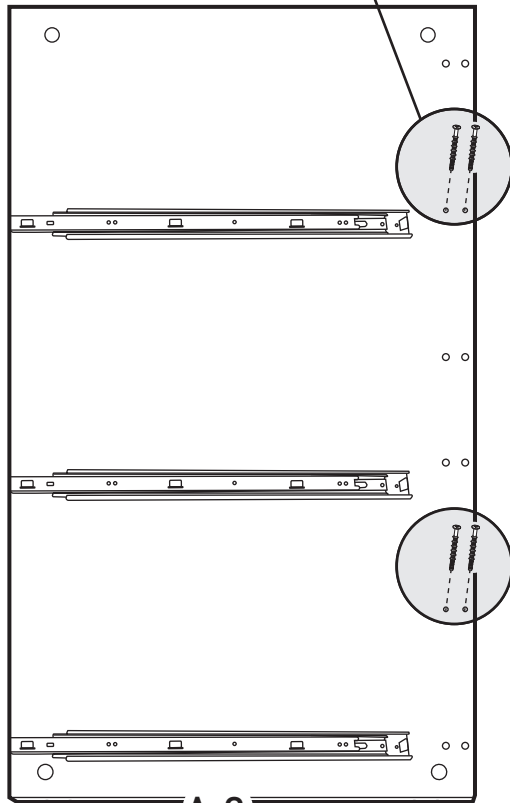
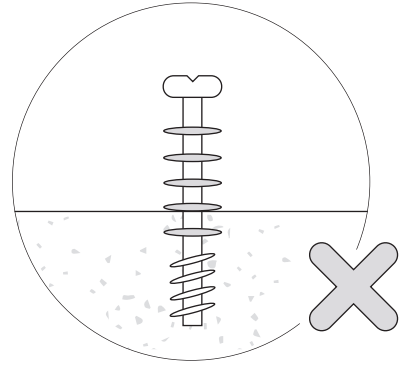
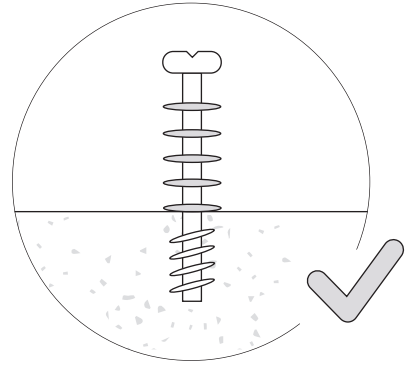

A-3

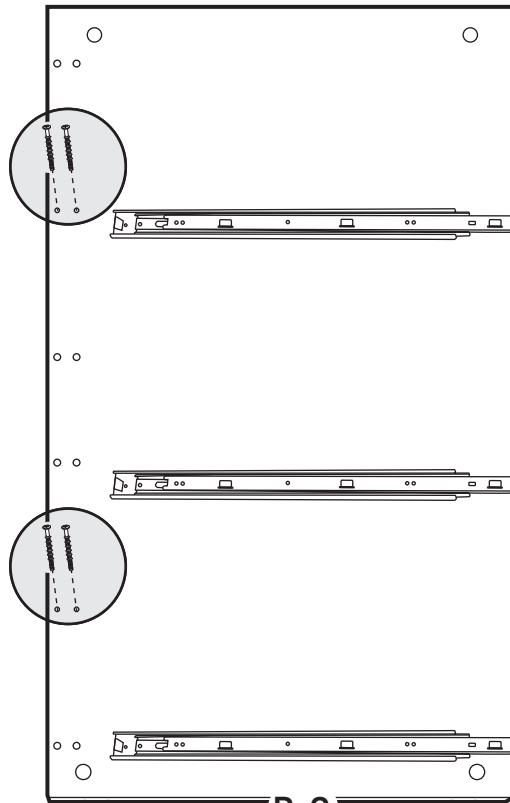

B-3

8

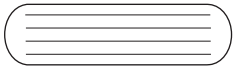

H5
x16

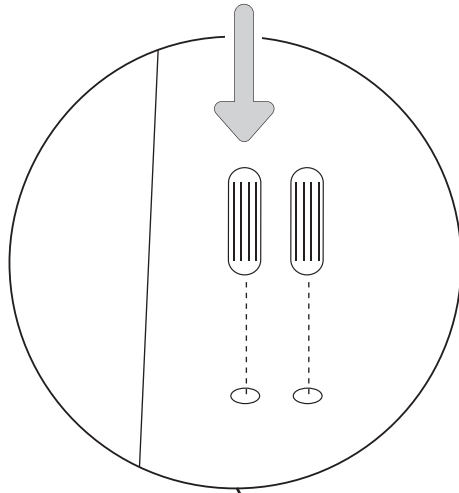

x8

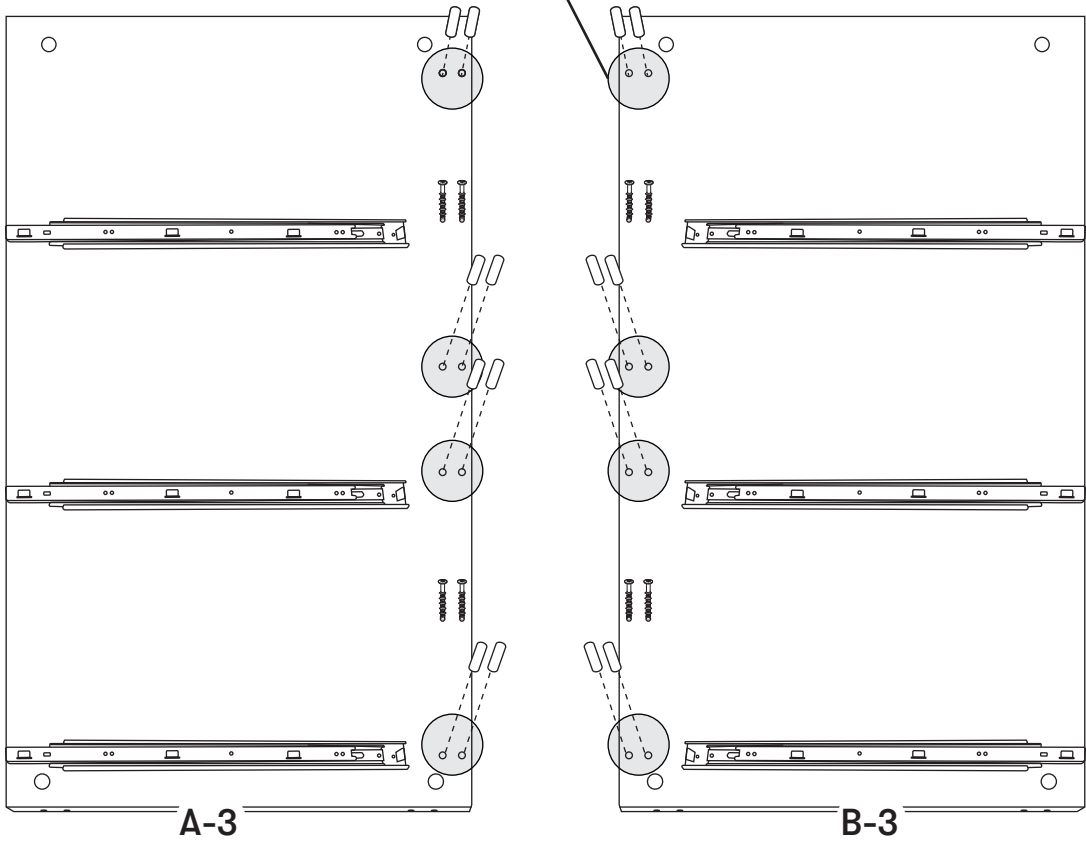

9

H4
x4

x4

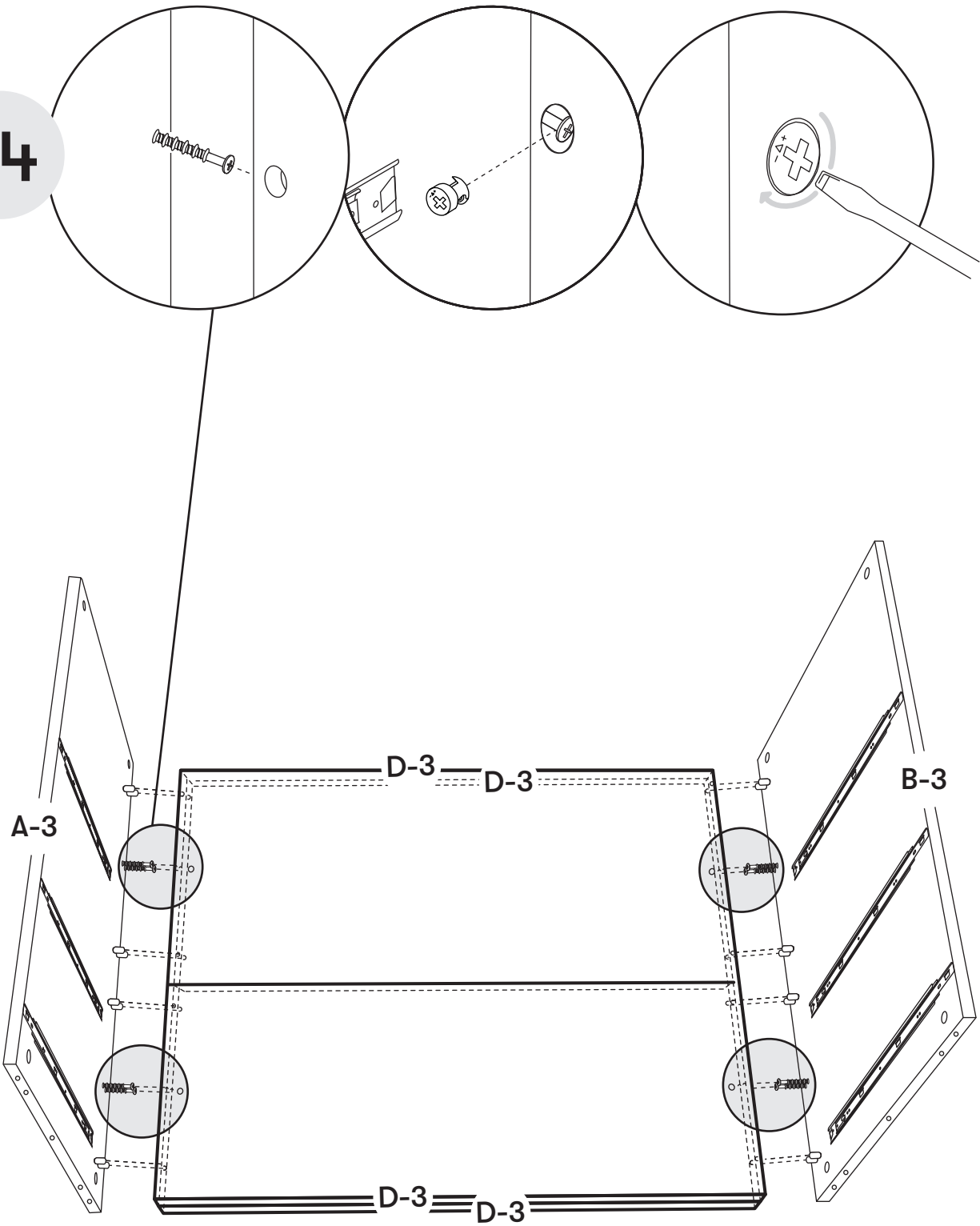

10



H4
x4

x4

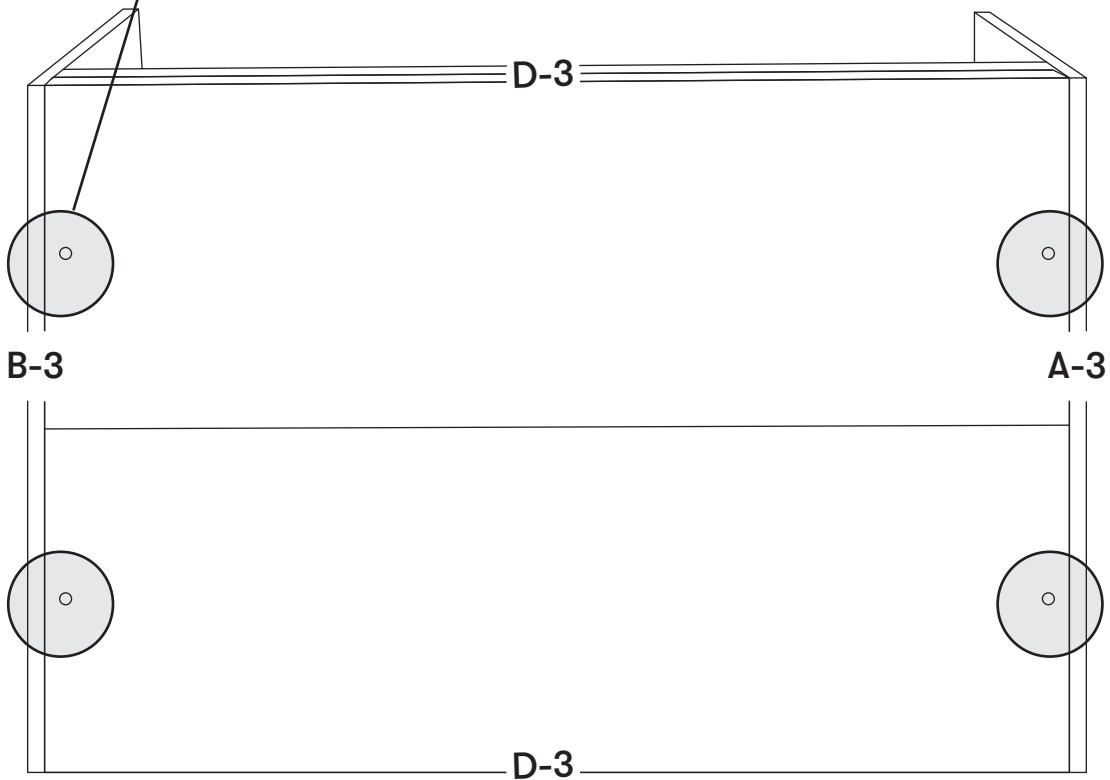
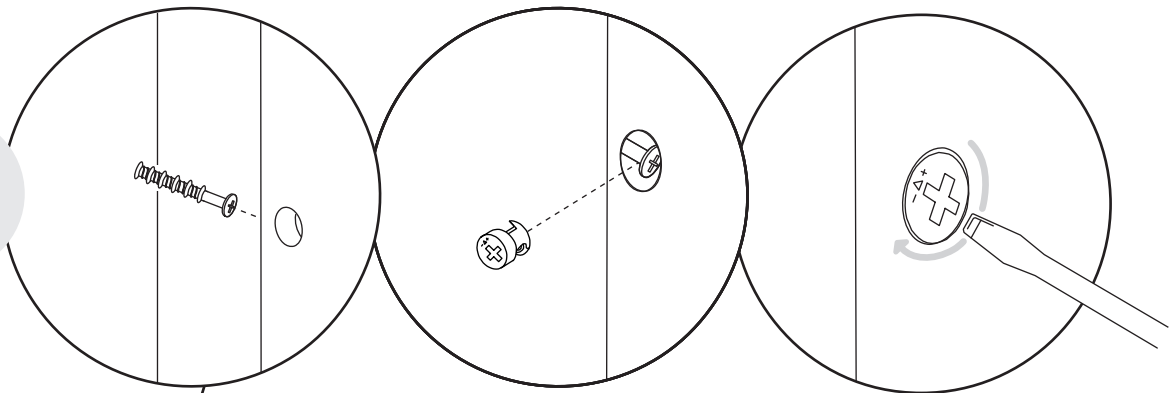

11

H4
x4

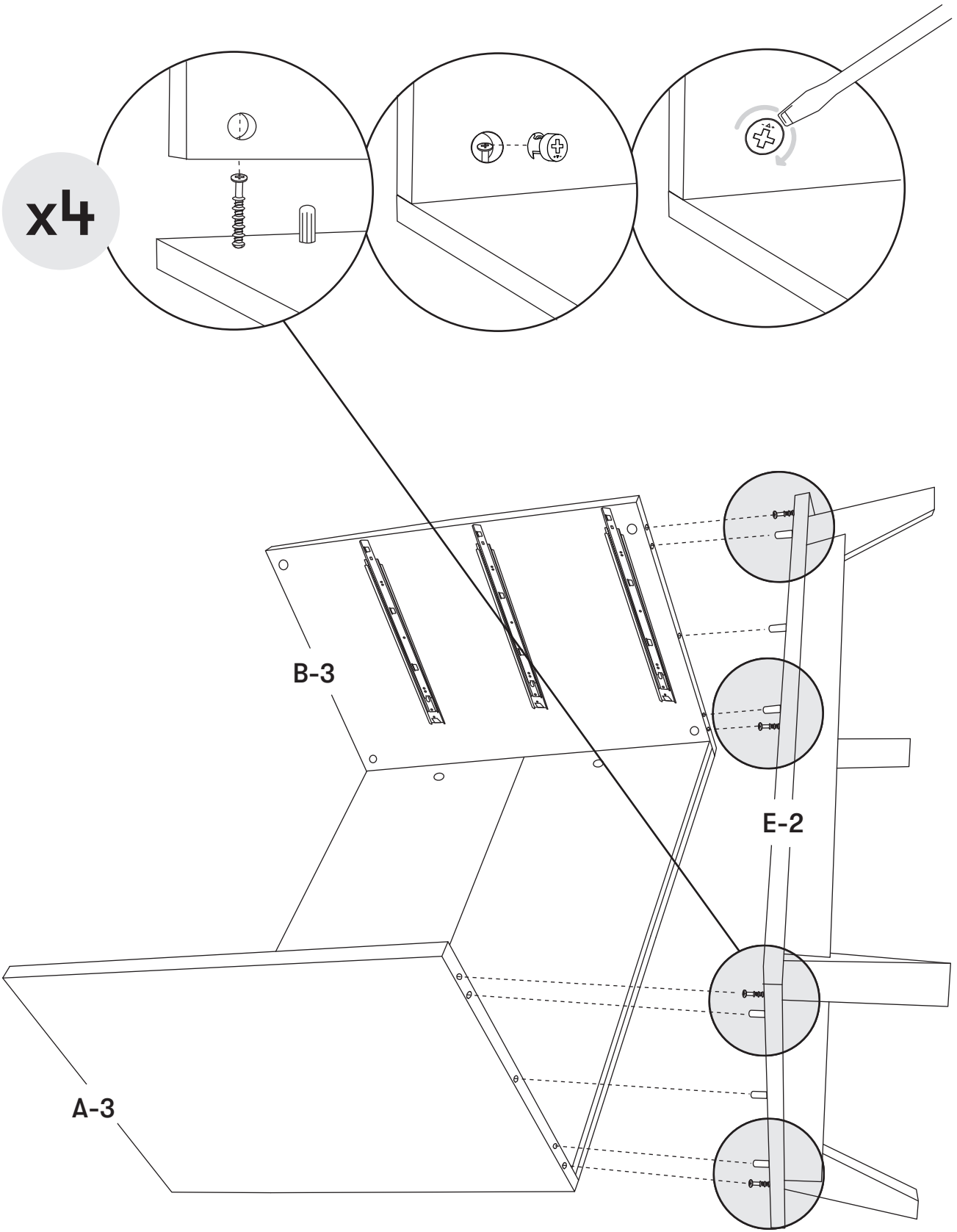

12

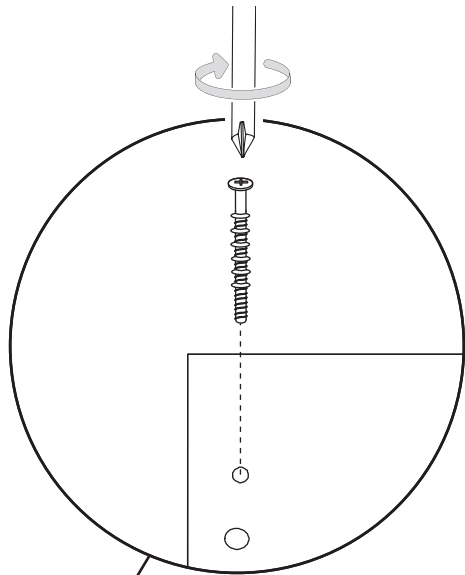

x4

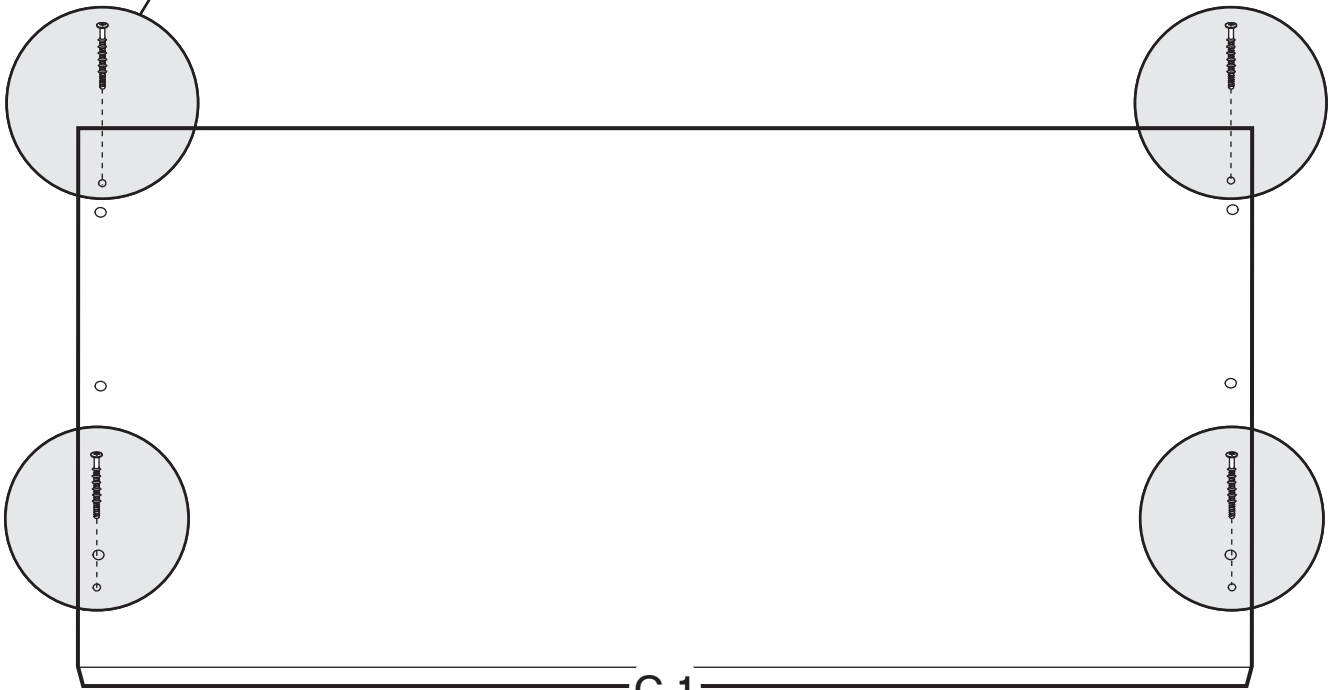
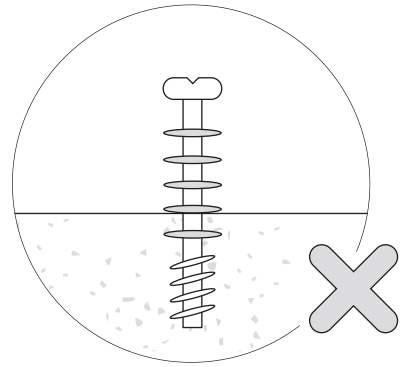
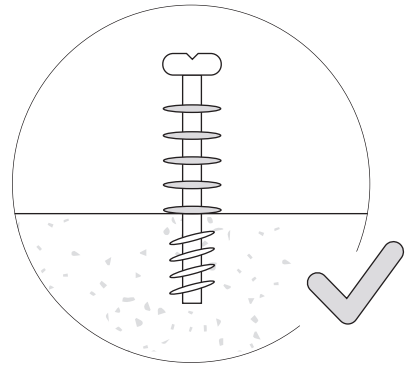

13

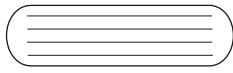

H5
x6

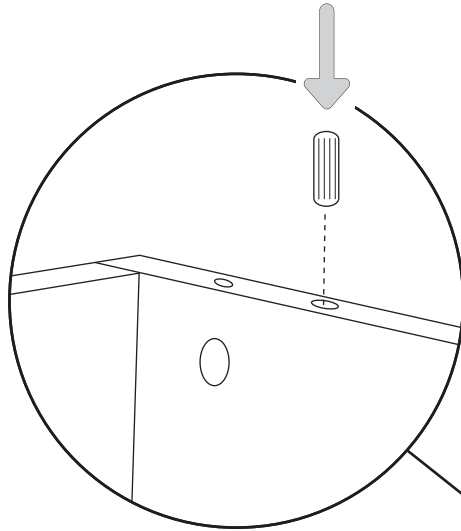

x6

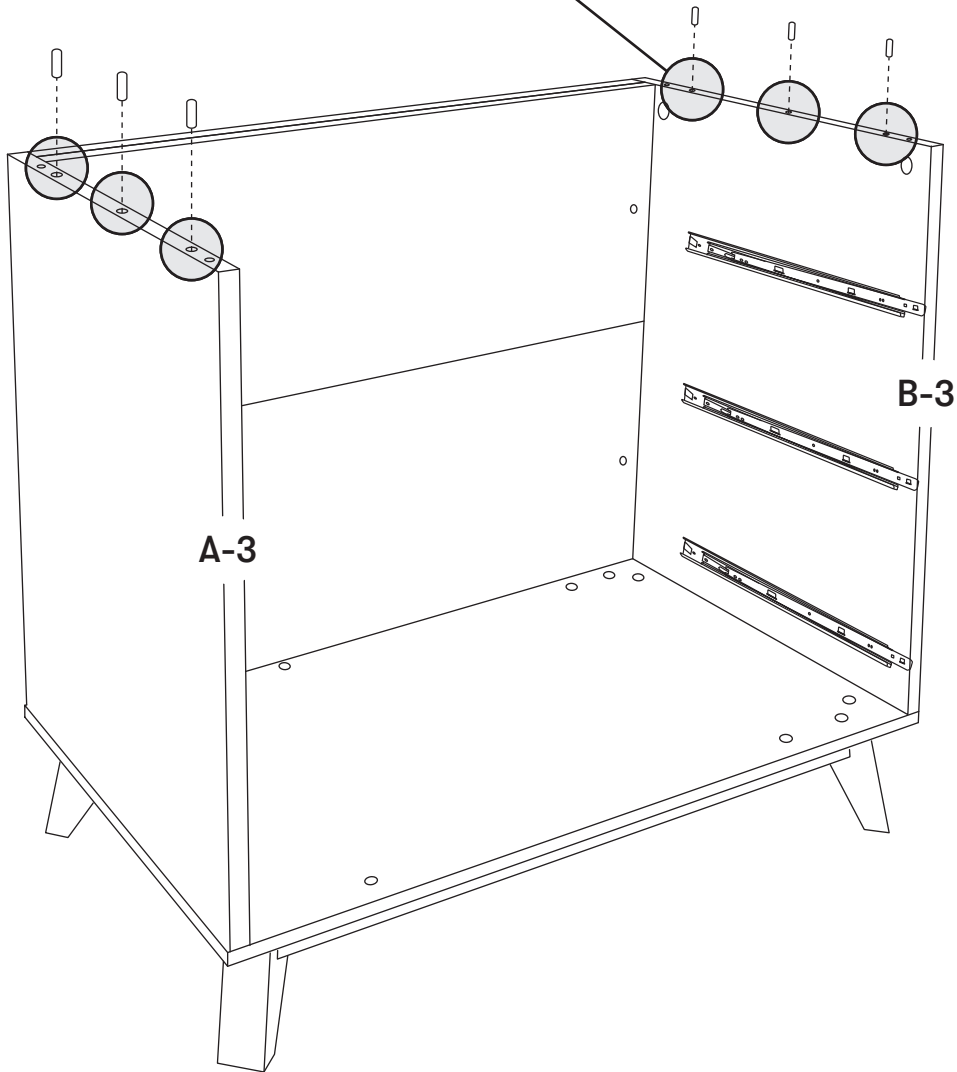

14

H4
x4

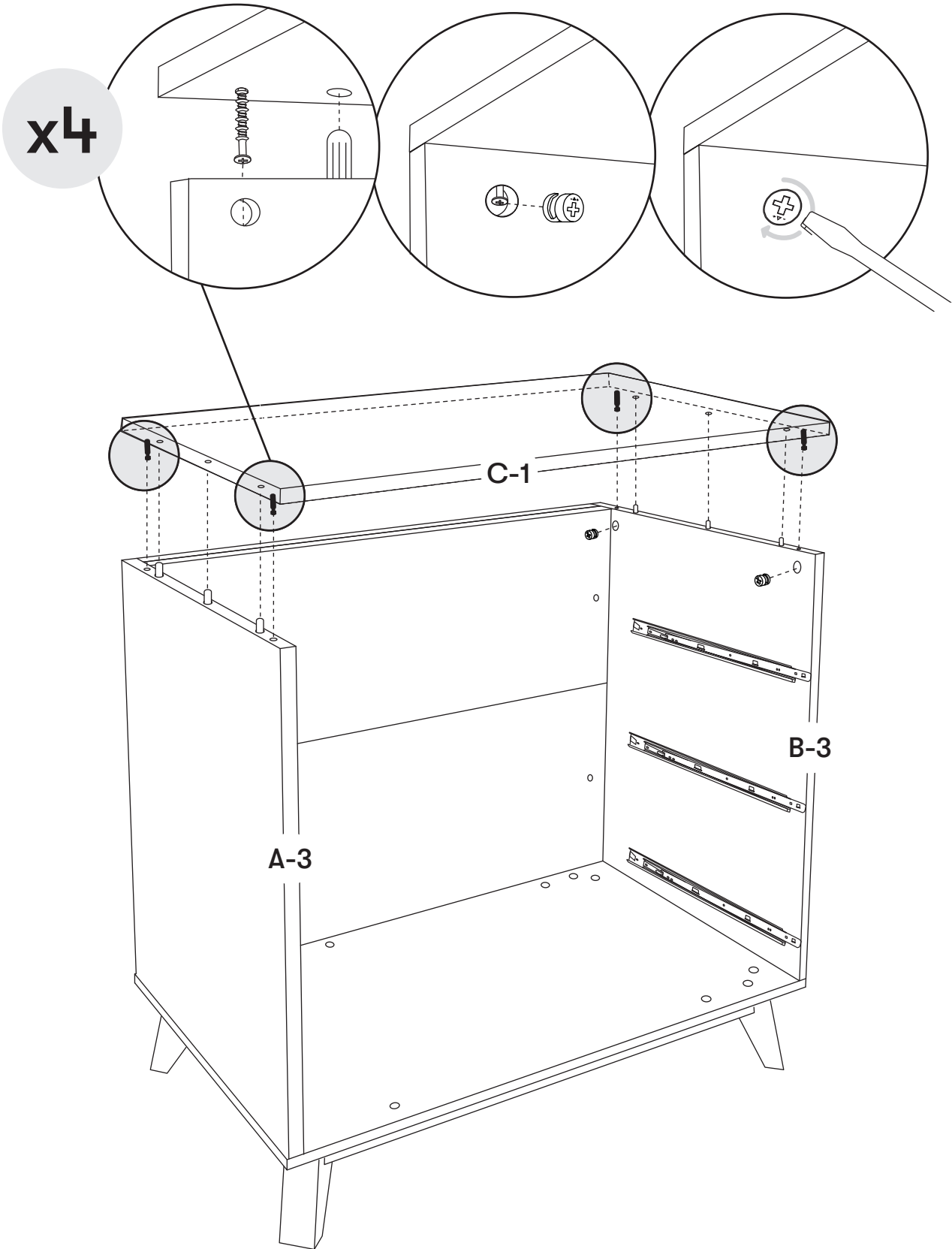

tray
parts

piezas de
la bandeja

pièces du
plateau

T-1

x2



TRAY FRONT / BACK RAIL
RIEL FRONTAL / POSTERIOR DE LA BANDEJA
BORDURE AVANT / ARRIÈRE DU PLATEAU

T-2

x2



TRAY SIDE RAIL
BANDEJA RIEL LATERAL
BORDURE DU PLATEAU

T-3



TRAY CROSS SUPPORT
BANDEJA DE SOPORTE CRUZADO
SUPPORT TRANSVERSAL DU PLATEAU

T-4

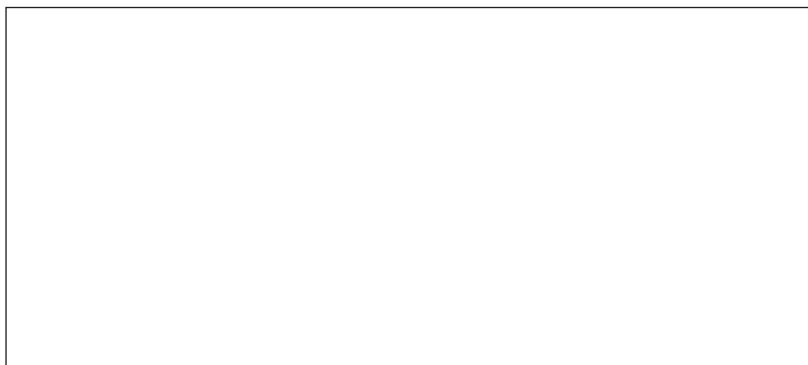

TRAY BOTTOM PANEL
PANEL INFERIOR DE LA BANDEJA
FOND DU PLATEAU

T-5



SAFETY STRAP
CORREA DE SEGURIDAD
SANGLE DE SÛRETÉ

hardware
actual size

herraje
tamaño real

matériel
taille actuelle

TH-1

x4

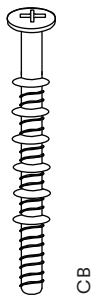

TH-2

x4



TH-3

x4



TH-4

x4

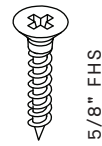

TH-5

x2

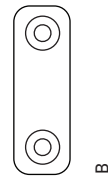

TH-7

x2

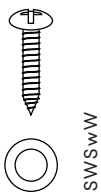

15a

TH-1
x4

TH-3
x4

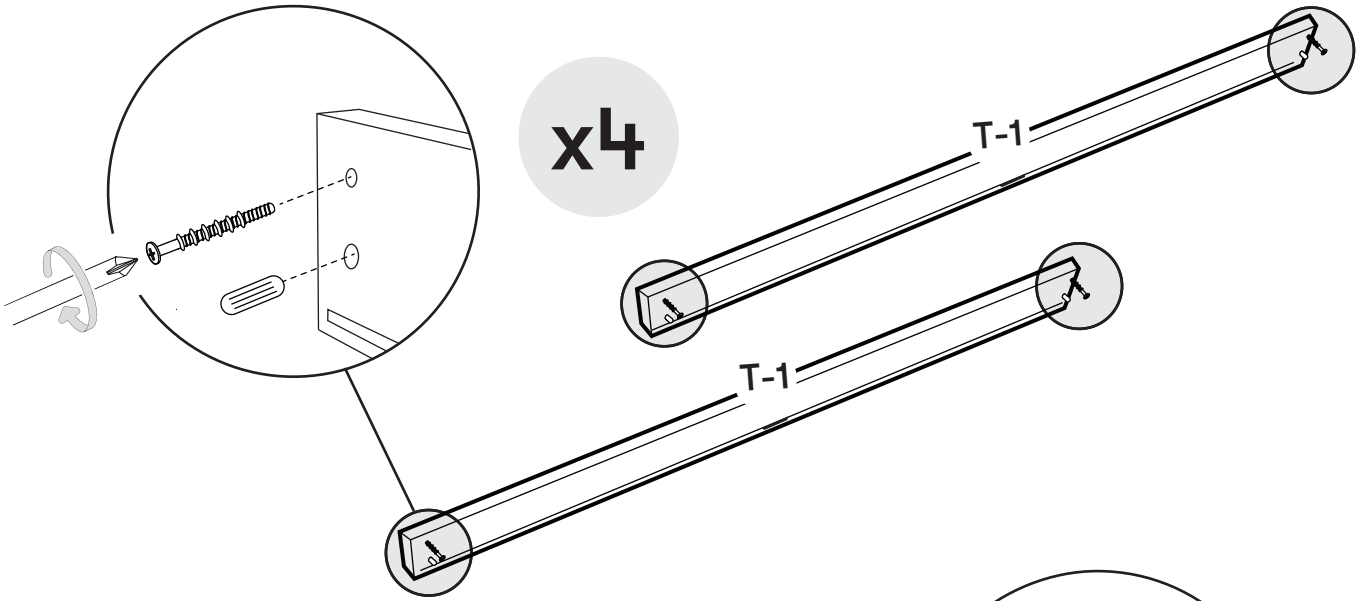

15b

TH-2
x2

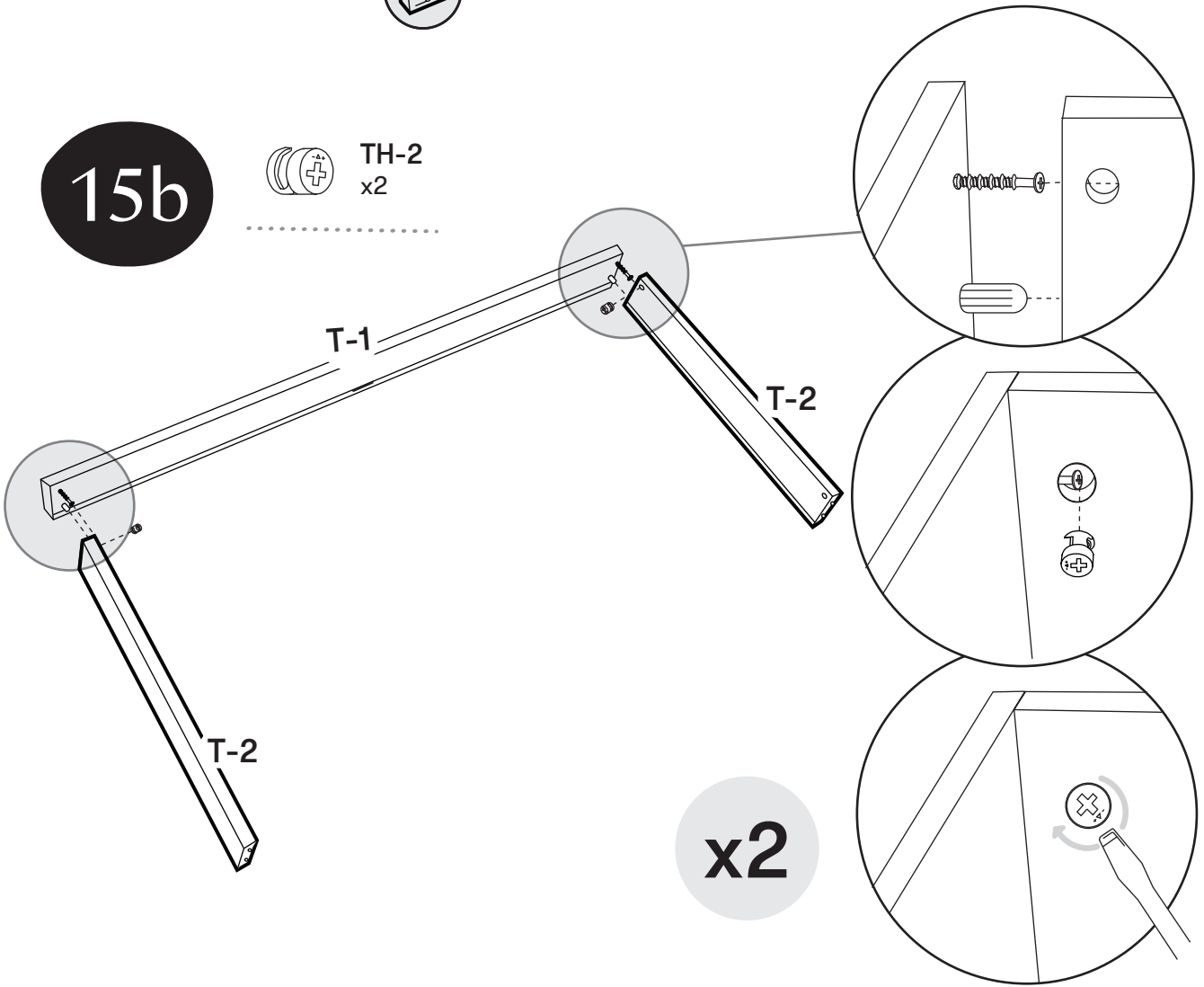

15c

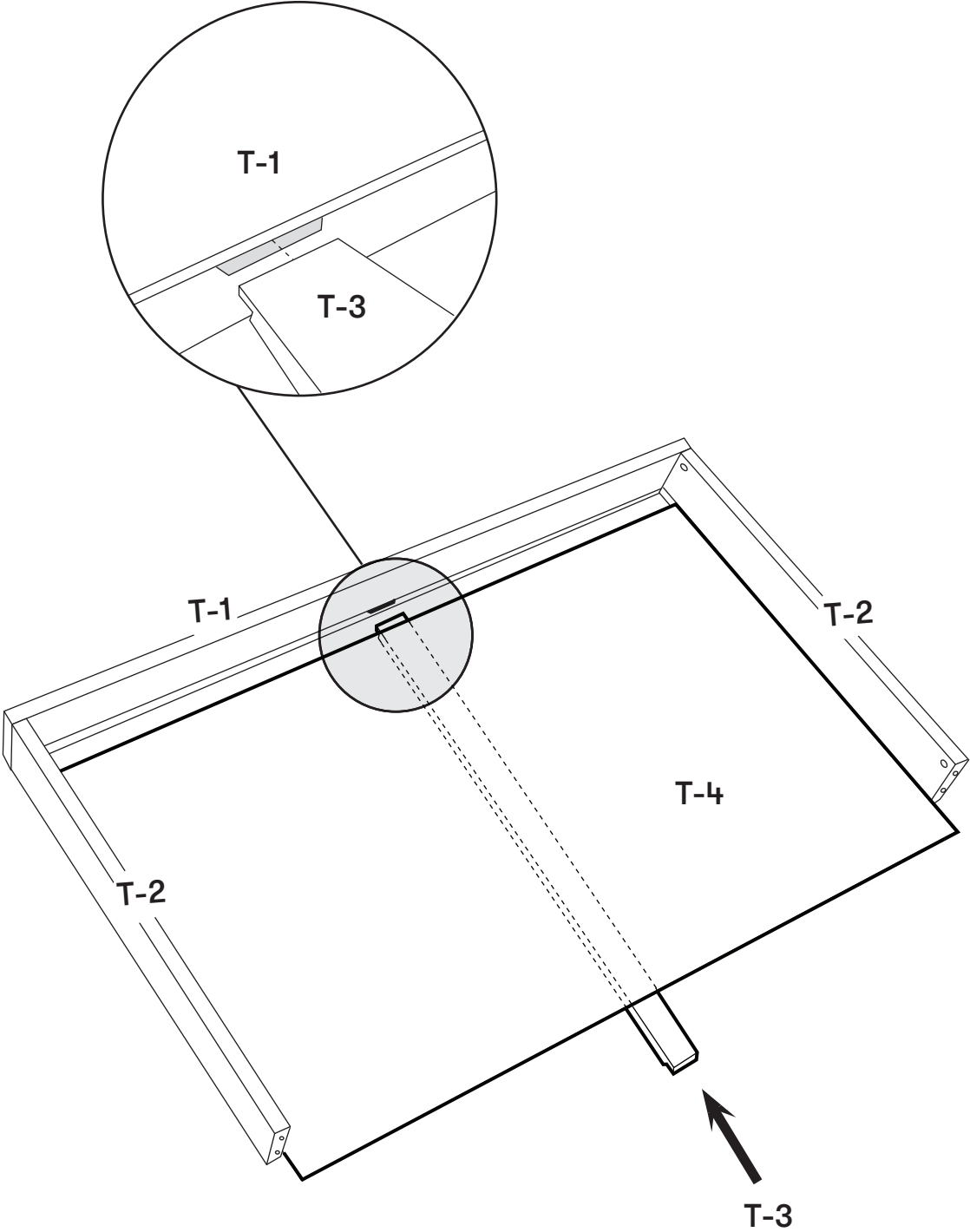

15d

TH-2
x2

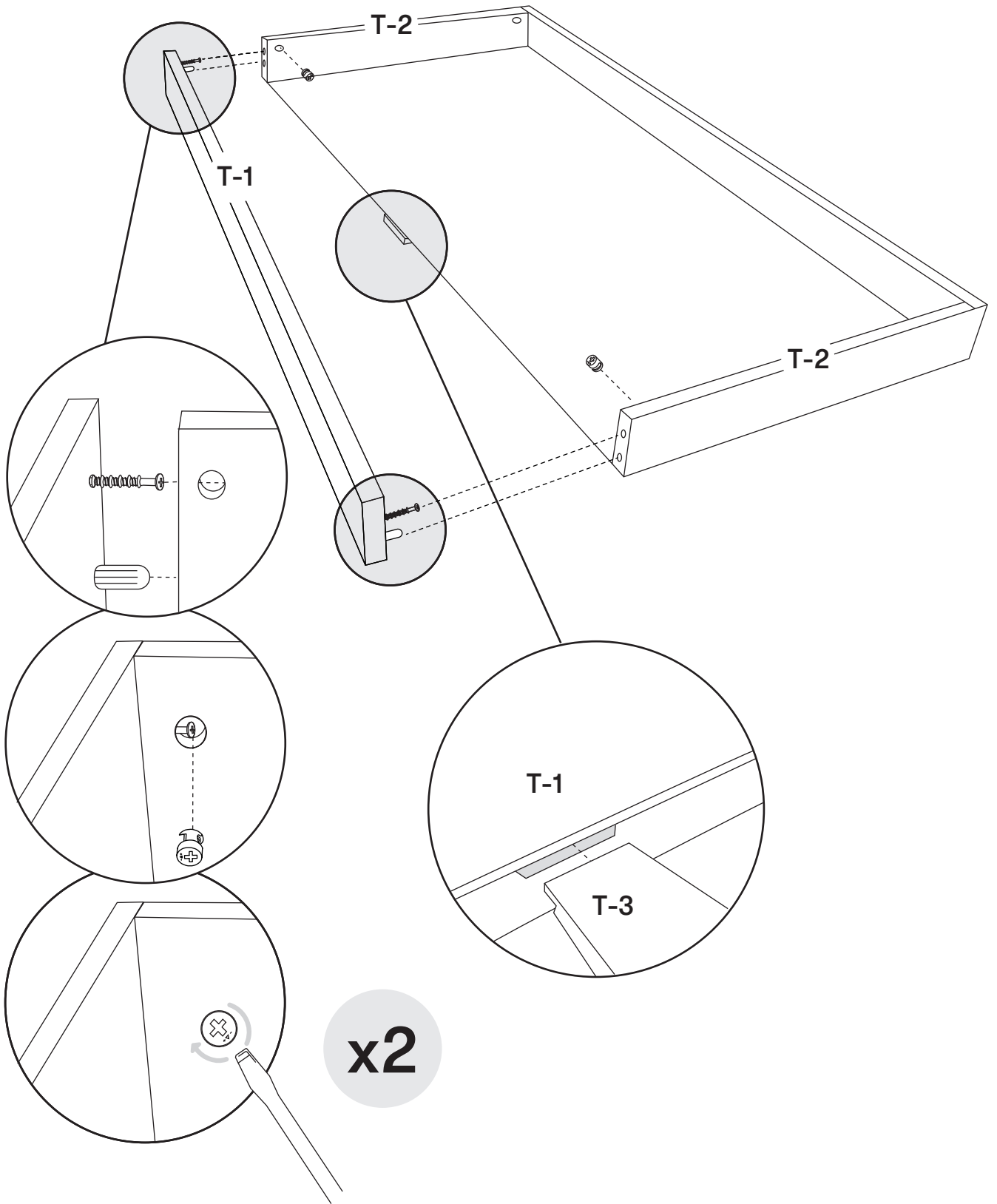

15e



TH-7
x2



x2

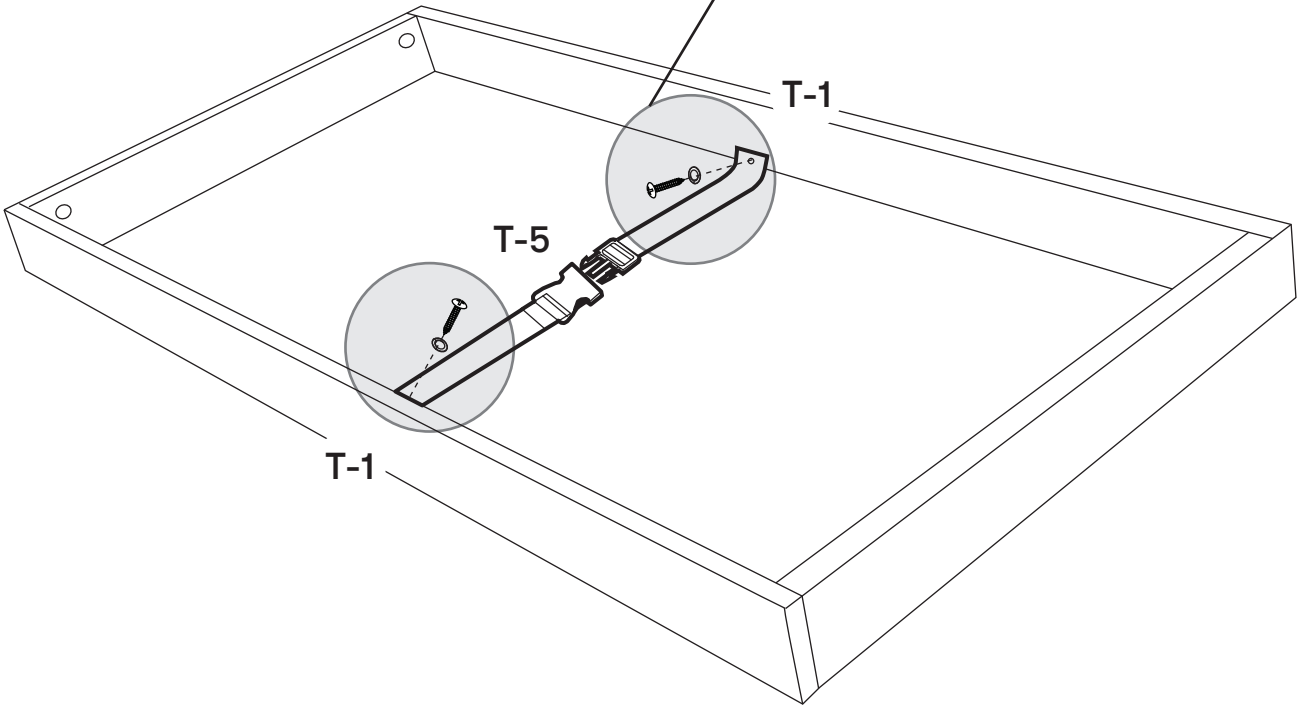
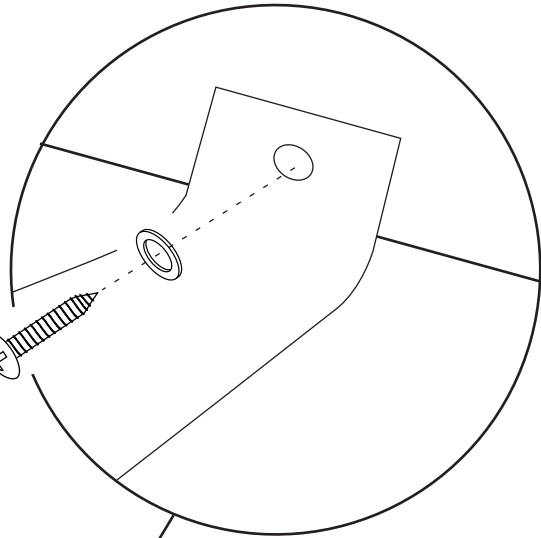

16

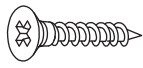

TH-4
x4

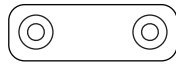

TH-5
x2

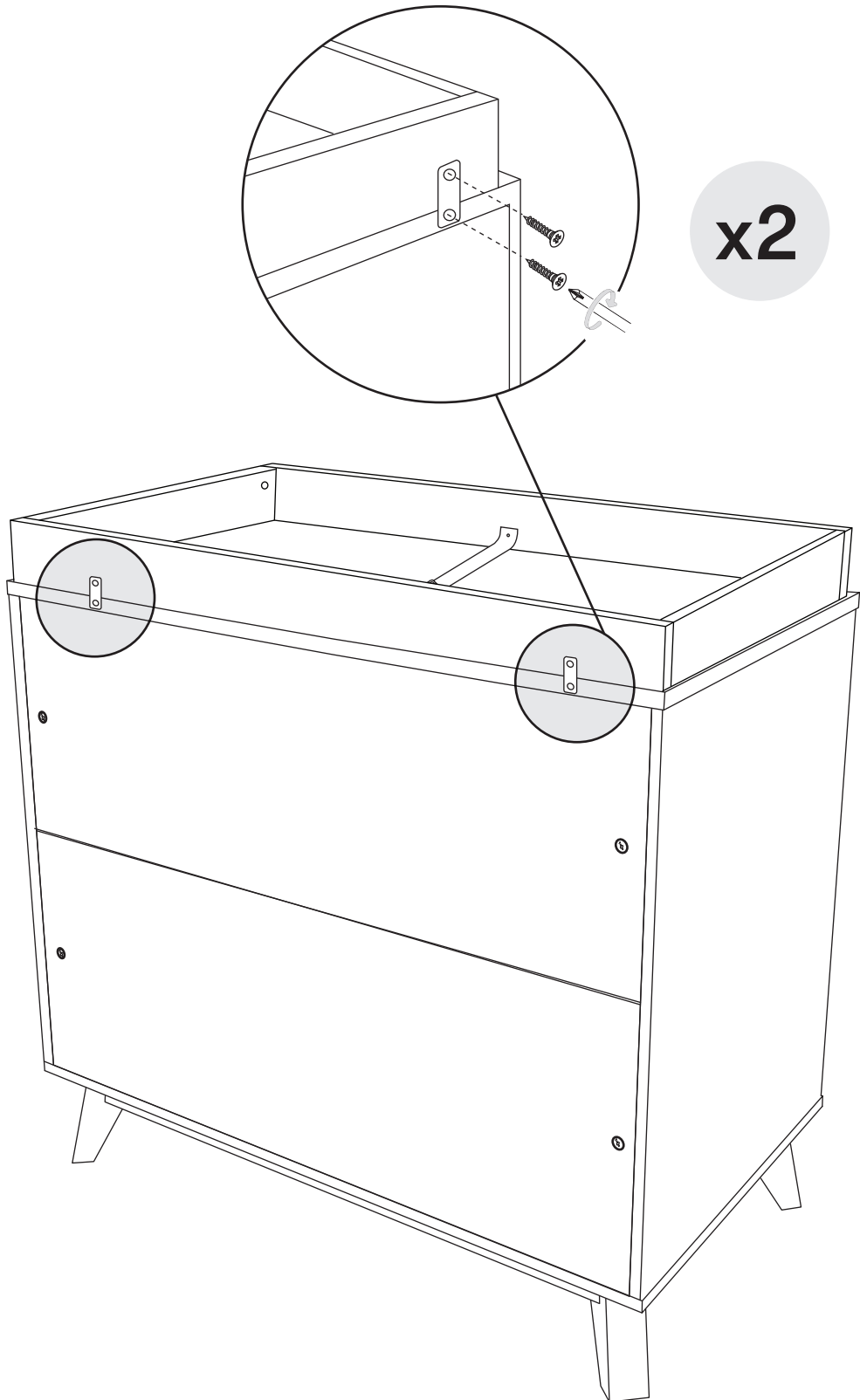

x2



restraint
system

sistema de
sujeción

systeme de
retenue

⚠ WARNING:
⚠ ADVERTENCIA:
⚠ AVERTISSEMENT:



- Secure your baby on the pad with the straps and buckle.
- Asegure al bebé sobre la almohadilla usando las correas y la hebilla.
- Sécurisez votre bébé sur le coussin avec les sangles et la boucle.

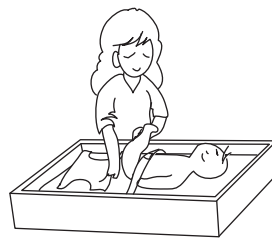

- After changing, unbuckle the straps.
- Después de cambiarlo, desabroche las correas.
- Après le changement de couche, détachez les sangles.



- Never leave your baby unattended on the changing tray.
- Nunca deje al bebé sin supervisión sobre la bandeja del mudador.
- Ne laissez jamais votre bébé sans surveillance sur le plateau à langer.

17

anti-tip kit
installation

instalación del kit
contra volcamientos

installation de la trousse
anti-basculement

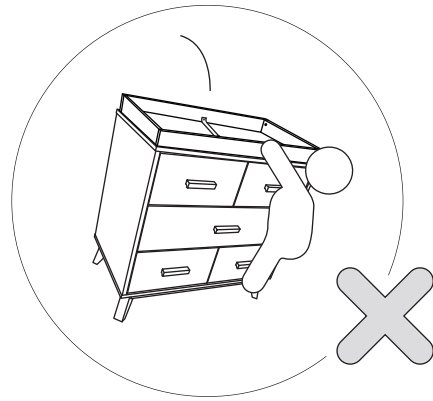
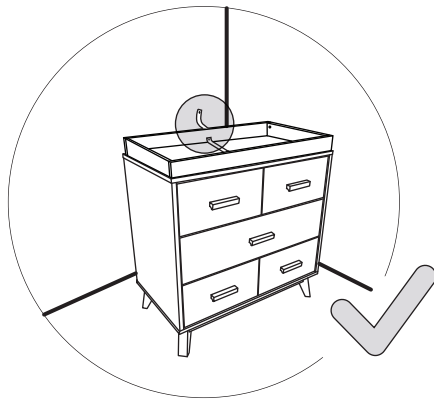

Children have died from furniture tipover. To reduce the risk of furniture tipover, **ALWAYS** install tip over restraint provided.

Han muerto niños al volcarse los muebles. Para reducir el riesgo de que se vuelque un mueble, **SIEMPRE** instale la sujeción contra volcamientos incluida.

Des enfants sont morts lors du basculement de meubles. Pour réduire le risque de basculement des meubles, veillez à **TOUJOURS** installer le dispositif de retenue fourni.

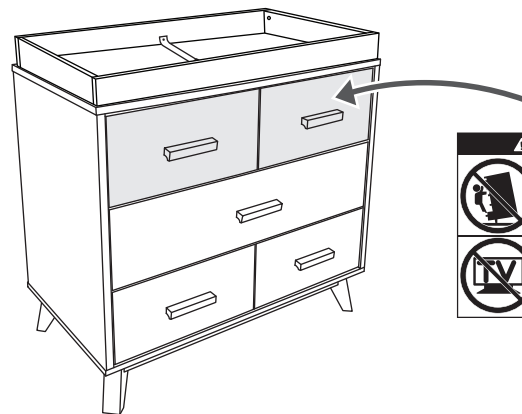

* Every detail of this dresser, including drawer extension, has been thoughtfully constructed in accordance with CPSC's ASTM F2507-23 standard to reduce tip-over risk.

* Cada detalle de esta cómoda, incluida la extensión del cajón, se ha construido cuidadosamente de acuerdo con la norma ASTM F2507-23 de la CPSC para reducir el riesgo de vuelco.

* Chaque détail de cette commode, y compris l'extension du tiroir, a été soigneusement construit selon la norme CPSC ASTM F2507-23 pour réduire le risque de renversement.

hardware
actual size

herraje
tamaño real

matériel
taille actuelle



X 1

For wall
Para la pared
Pour le mur



X 1

For dresser
Para la cómoda
Pour la commode

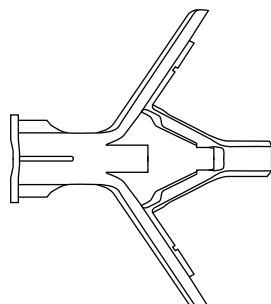

X2

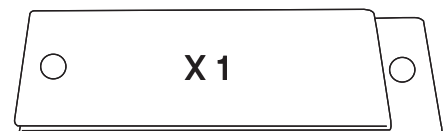

X 1

X 1

For drywall
Para tablaroca
Pour une cloison en plâtre

EN

Find your wall material and follow steps to attach the anti-tip kit to your wall.

Drywall or plaster with available wood stud:

- Mark the attachment point with a pencil, 1" to 2" (25-50 mm) below top of dresser, positioned over a wood stud.
- Drill 1/8-inch (3 mm) diameter pilot hole into the wood stud, on the pencil mark.
- Following the appropriate pictogram instructions on the following pages, drive the screw with washer through the textile strap and tighten screw firmly into the wood.

Drywall without available wood stud:

- Mark the attachment point with a pencil, 1" to 2" (25-50 mm) below top of dresser.
- Drill 3/8-inch (9 mm) diameter hole through the wall, on the pencil mark.
- Drive the plastic anchor into the hole, using a hammer if needed.
- Following the appropriate pictogram instructions on the following pages, drive the screw with washer through the textile strap and tighten screw firmly into the plastic anchor in the wall. Do not over-tighten.

If your wall material is not listed here, or if you have any questions, consult your local hardware store.

ES

Determine el material de la pared y siga los pasos para instalar el kit anti-volcamientos en la pared.

Tablaroca o panel de yeso con remache de madera disponible:

- Marque el punto de sujeción con un lápiz, 25-50 mm (1-2 pulgadas) bajo la parte superior de la cómoda, posicionado sobre un remache de madera.
- Taladre un agujero guía de 3 mm (1/8 pulgada) de diámetro en el remache de madera, sobre la marca hecha con el lápiz.
- Siguiendo las instrucciones correspondientes del pictograma en las páginas siguientes, instale el tornillo con arandela a través de la tira textil y apriete el tornillo firmemente en la madera.

Tablaroca sin remache de madera disponible:

- Marque el punto de sujeción con un lápiz, 25-50 mm (1-2 pulgadas) bajo la parte superior de la cómoda.
- Taladre un agujero guía de 9 mm (3/8 pulgada) de diámetro en la pared, sobre la marca hecha con el lápiz.
- Instale la fijación de plástico en el agujero, usando un martillo si es necesario.
- Siguiendo las instrucciones correspondientes del pictograma en las páginas siguientes, instale el tornillo con arandela a través de la tira textil y apriete el tornillo firmemente en la fijación de plástico en la pared. No apriete en exceso.

Si no aparece indicado aquí el material de la pared, o si tiene alguna pregunta, consulte con su ferretería local.

FR

Trouvez votre propre matériau mural et suivez les étapes pour fixer la trousse anti-basculément à votre mur.

Cloison sèche et en plâtre avec montants en bois :

- Marquez le point de fixation à l'aide d'un crayon à une distance de 25 à 50 mm (1 à 2 po) sous le dessus de la commode, placé sur un montant en bois.
- Percez un avant-trou d'un diamètre de 3 mm (1/8 po) dans le montant en bois, sur la marque de crayon.
- Suivez les instructions sous forme de pictogramme correspondantes figurant sur les pages suivantes, insérez la vis et la rondelle dans la sangle de tissu, puis vissez fermement la vis dans le montant en bois.

Cloison sèche sans montant en bois :

- Marquez le point de fixation à l'aide d'un crayon à une distance de 25 à 50 mm (1 à 2 po) sous le dessus de la commode.
- Percez un avant-trou d'un diamètre de 9 mm (3/8 po) dans le montant en bois, sur la marque de crayon.
- Insérez l'ancrage en plastique dans le trou, à l'aide d'un marteau au besoin.
- Suivez les instructions sous forme de pictogramme correspondantes figurant sur les pages suivantes, insérez la vis et la rondelle dans la sangle de tissu, puis vissez fermement dans l'ancrage en plastique du mur. Ne serrez pas excessivement.

Si le matériau de votre mur ne figure pas dans la liste ci-dessus, ou si vous avez des questions, adressez-vous à votre fournisseur local.

17a

Fasten strap to back of dresser.

Fije la tira en la parte posterior de la cómoda.

Fixez la sangle à l'arrière de la commode.

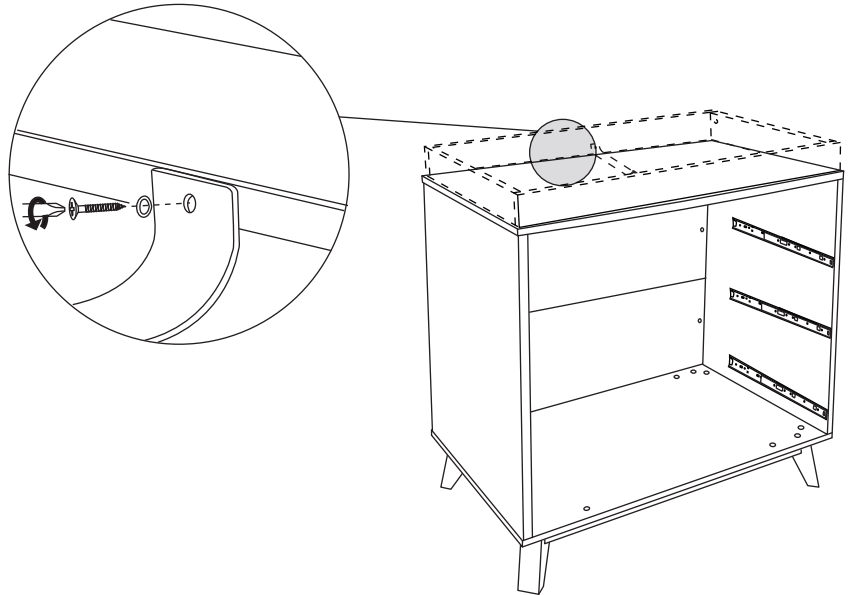

17b

Mark spot on wall 1-2" (25-50mm) below the top of the dresser.

Marque el punto en la pared a 25-50 mm (1-2 pulgadas) debajo de la parte superior de la cómoda.

Marquez le point sur le mur à une distance de 25 à 50 mm (1 à 2 po) sous le dessus de la commode.

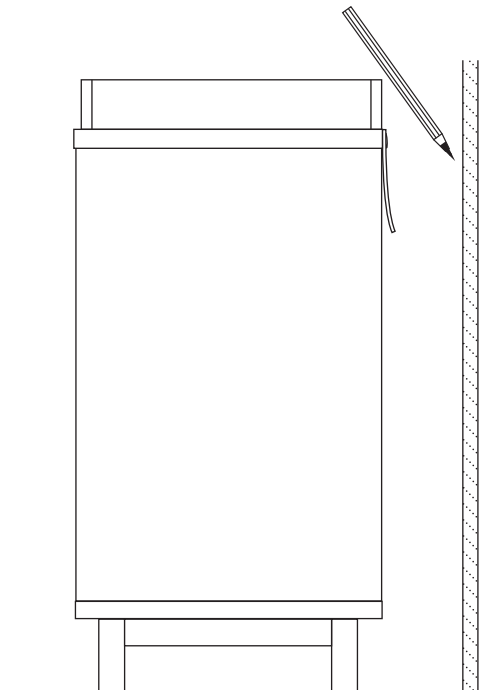

17c

Follow the "Find Your Wall Material" instructions on the previous page. Drill a 3/8" (9 mm) hole and insert plastic anchor into hole (if needed).

Siga las "Instrucciones según el tipo de material de la pared" en la página anterior.

Taladre un agujero de 9 mm (3/8 pulgada) e inserte la fijación de plástico en el agujero (si es necesario).

Trouvez votre matériau mural et suivez les instructions portant sur le « Type de matériau du mur » de la page ci-dessus. Percez un trou de 9 mm (3/8 po) et insérez l'ancrage en plastique dans le trou (au besoin).

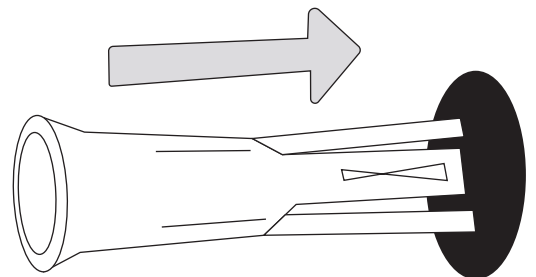

17d

Fasten strap/bracket by screwing into plastic anchor or wood stud.

Fije la tira/el soporte atornillando en la fijación de plástico o el remache de madera.

Fixez la sangle/le support par vissage dans l'ancrage de plastique ou le montant en bois.

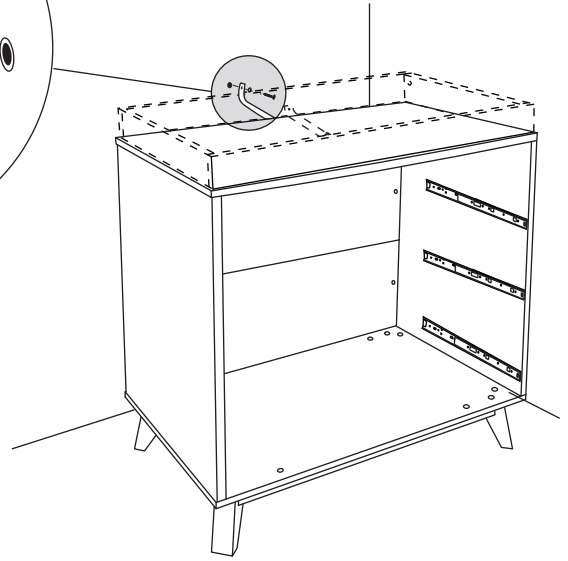
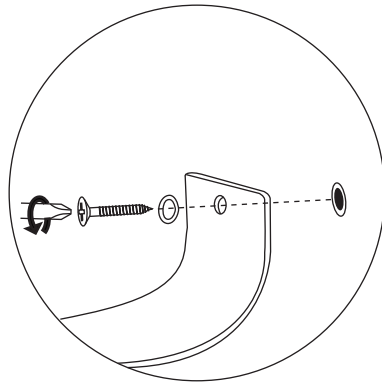

17e

Complete!

¡Listo!

C'est terminé!

* Drywall without available wood stud.

* Tablaroca sin remache de madera disponible.

* Cloison sèche sans montant en bois.

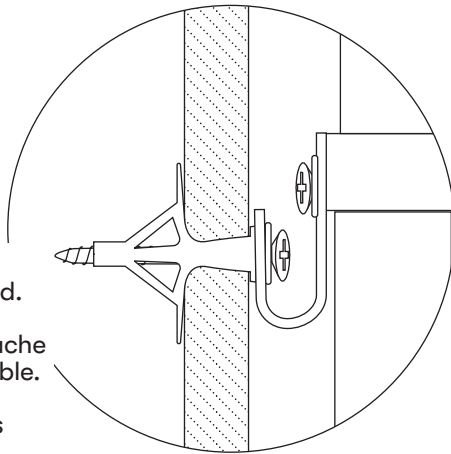

* Drywall or plaster with available wood stud.

* Tablaroca o panel de yeso con remache de madera disponible.

* Cloison sèche et en plâtre avec montants en bois.

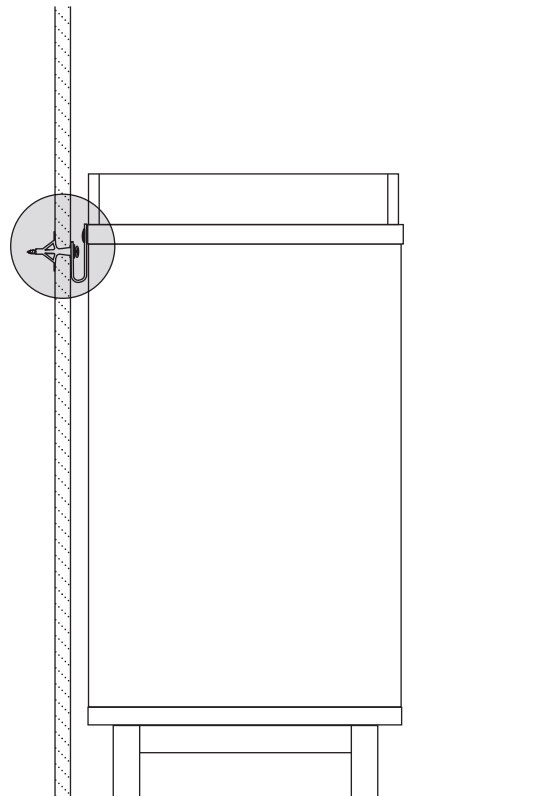
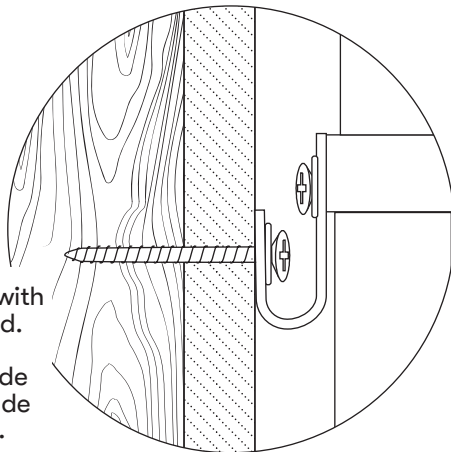

18a



H11
x4

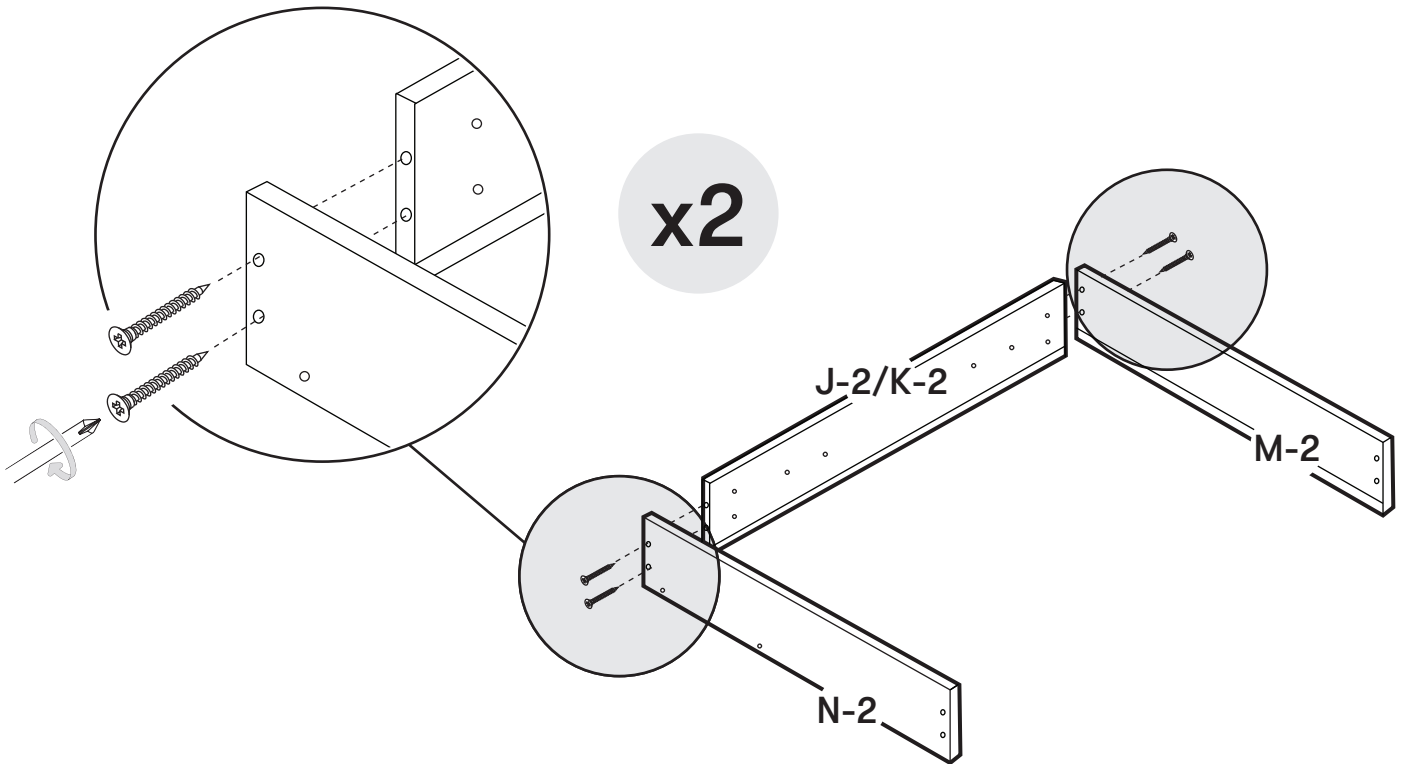

18b

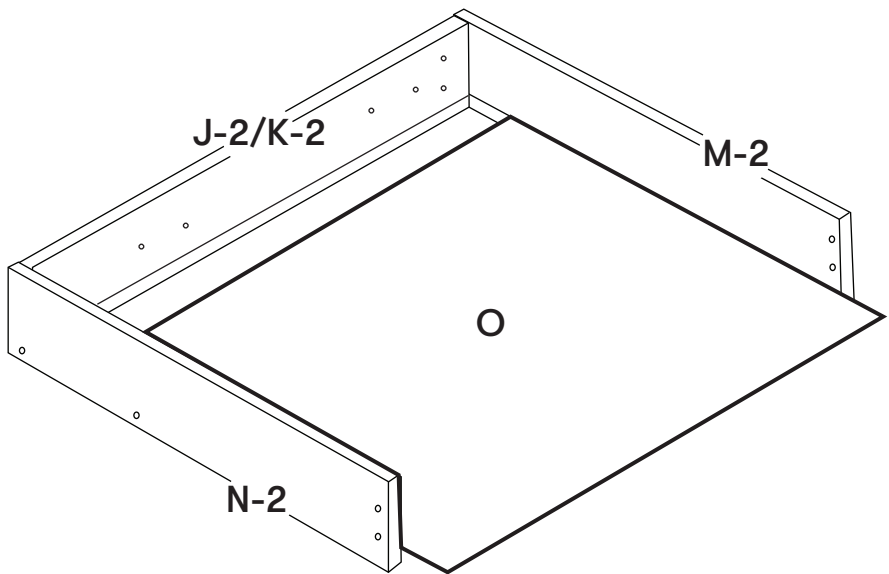

18c



H11
x4

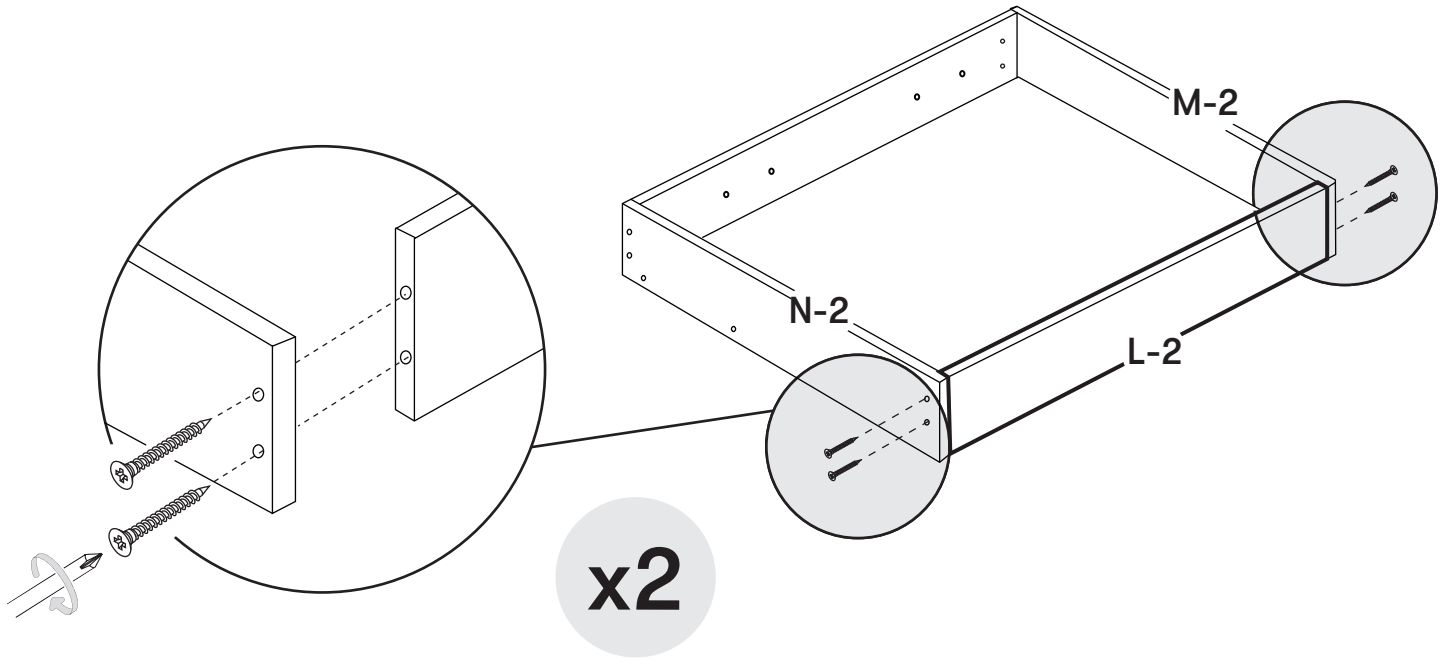

18d

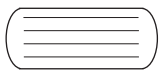

H10
x2



H11
x4

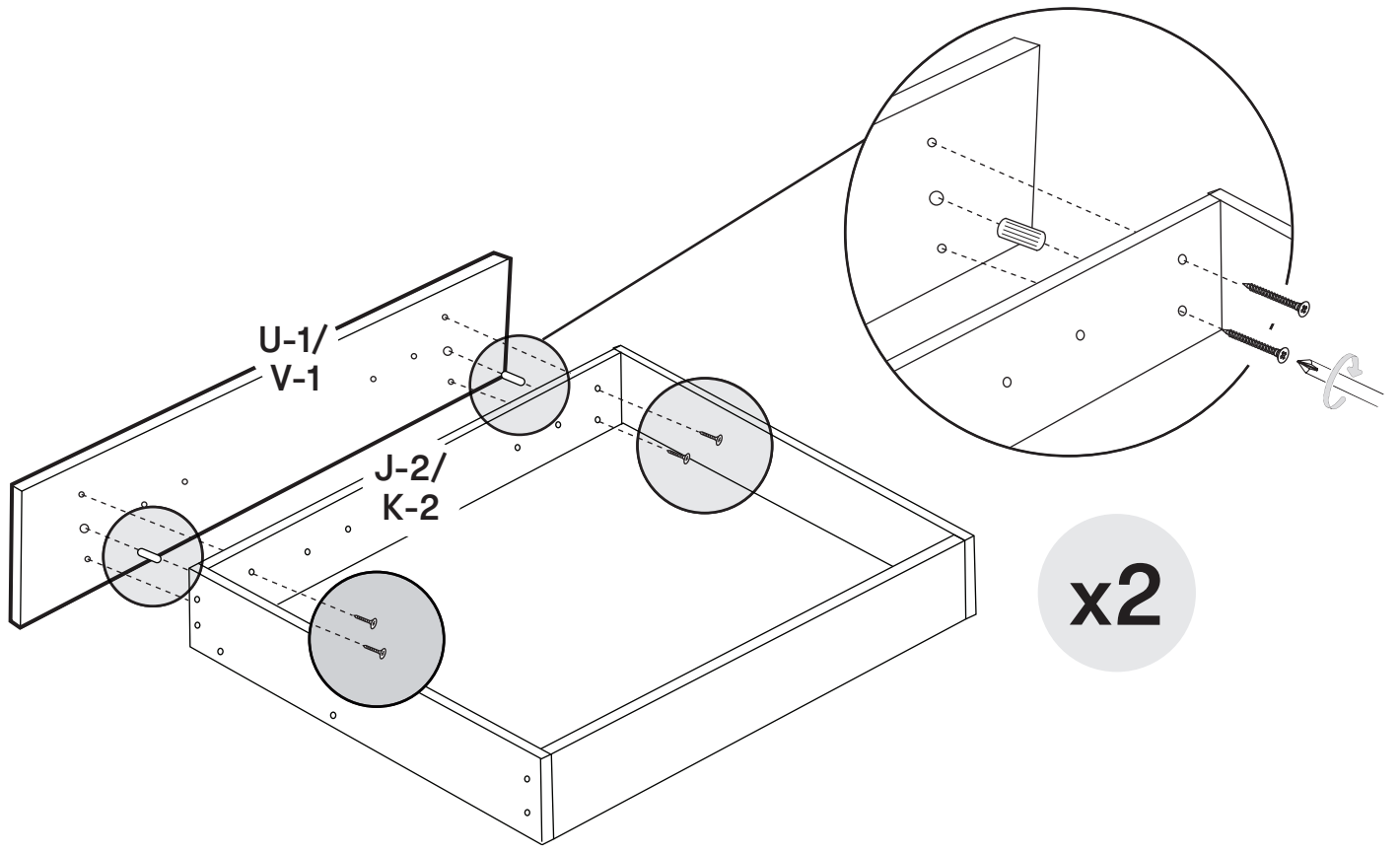

18e



H8
x4

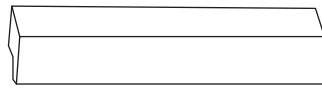

H9
x2

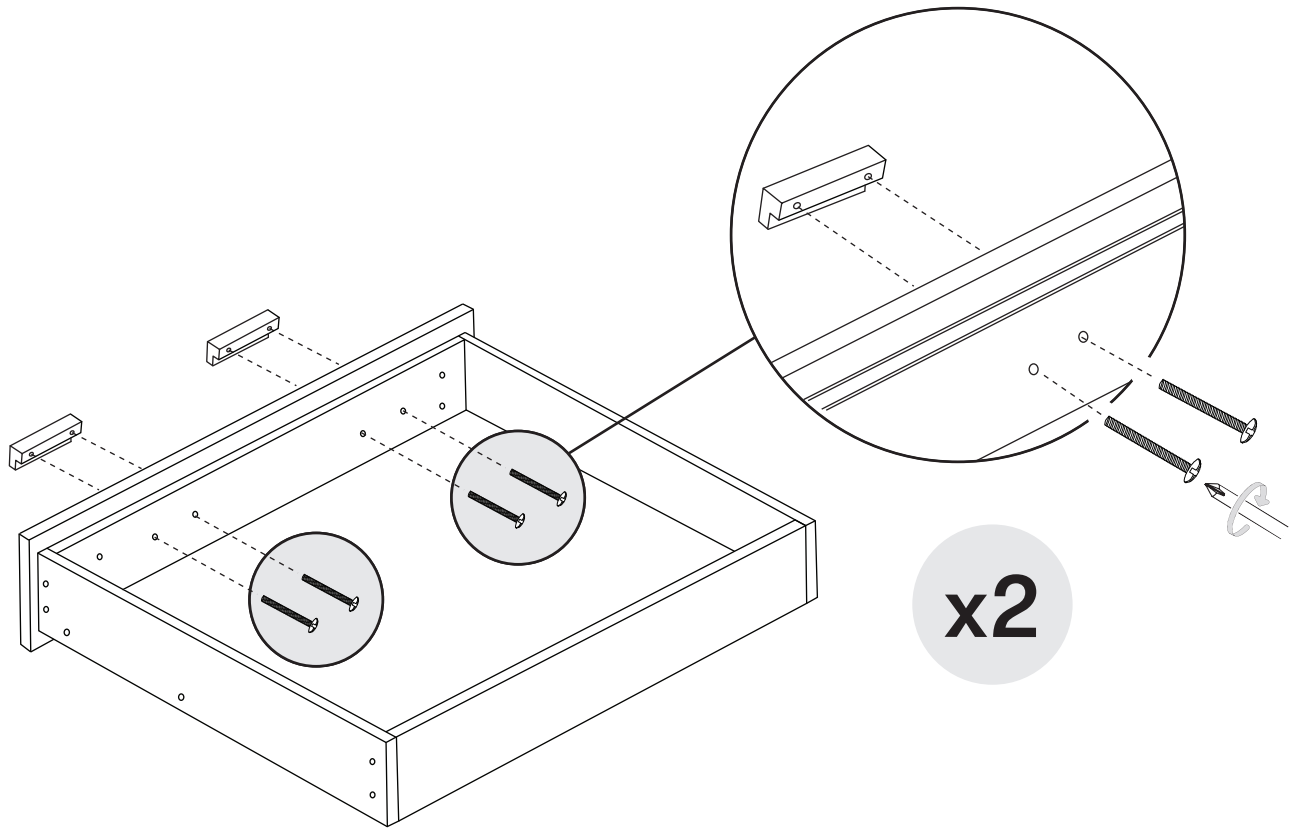

18f

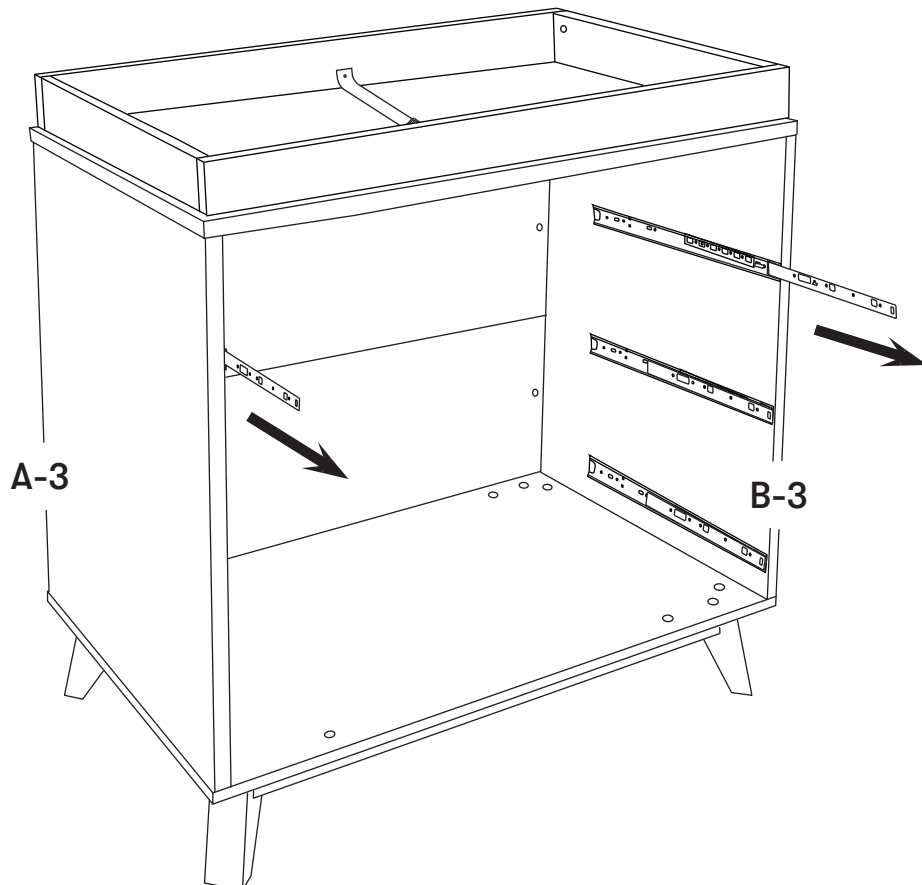

18g

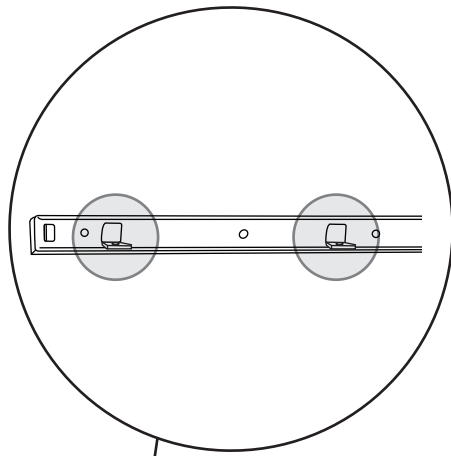

x2

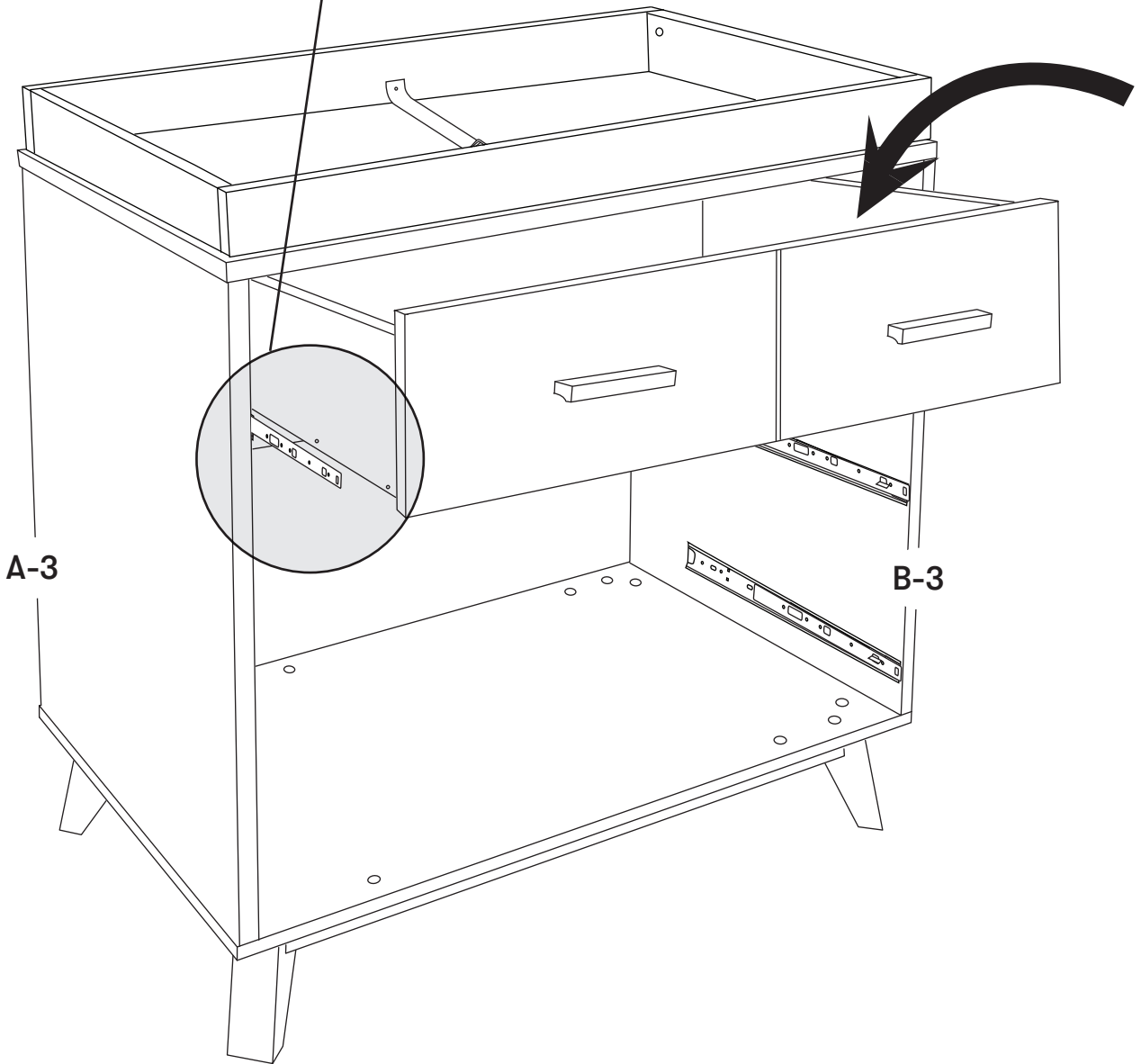

A-3

B-3

18h

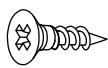

H2
x4

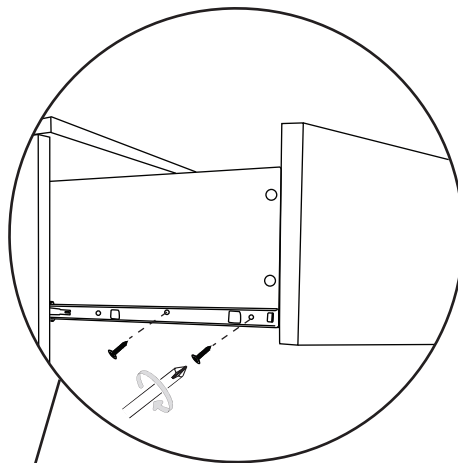

x2

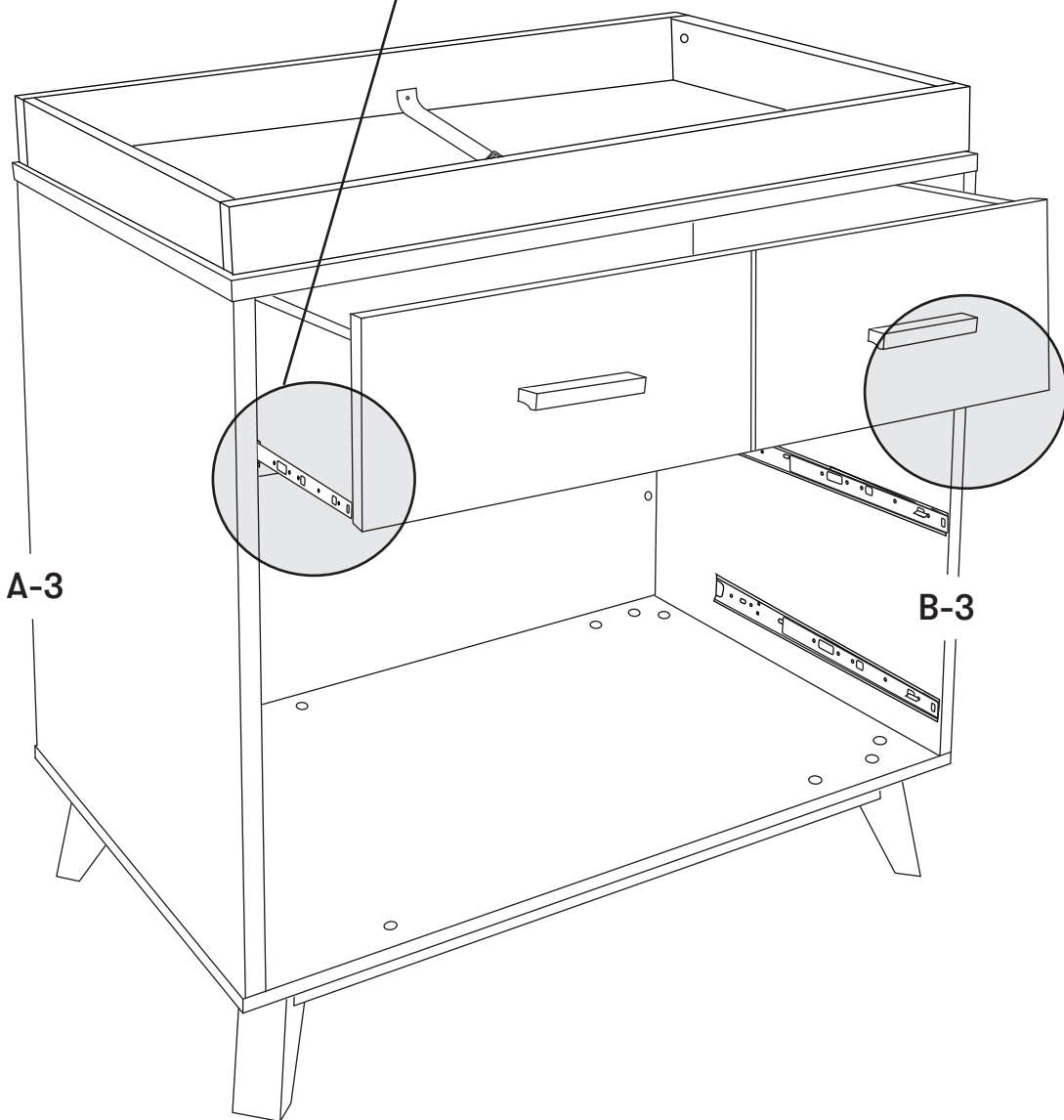

A-3

B-3



DO NOT OVERTIGHTEN THE SCREWS.
NO APRIETE LOS TORNILLOS EN EXCESO.
NE SERREZ PAS TROP LES VIS.

19

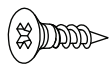

H2
x8



H8
x6

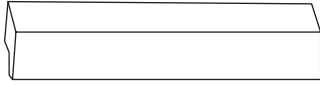

H9
x3

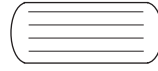

H10
x4



H11
x24

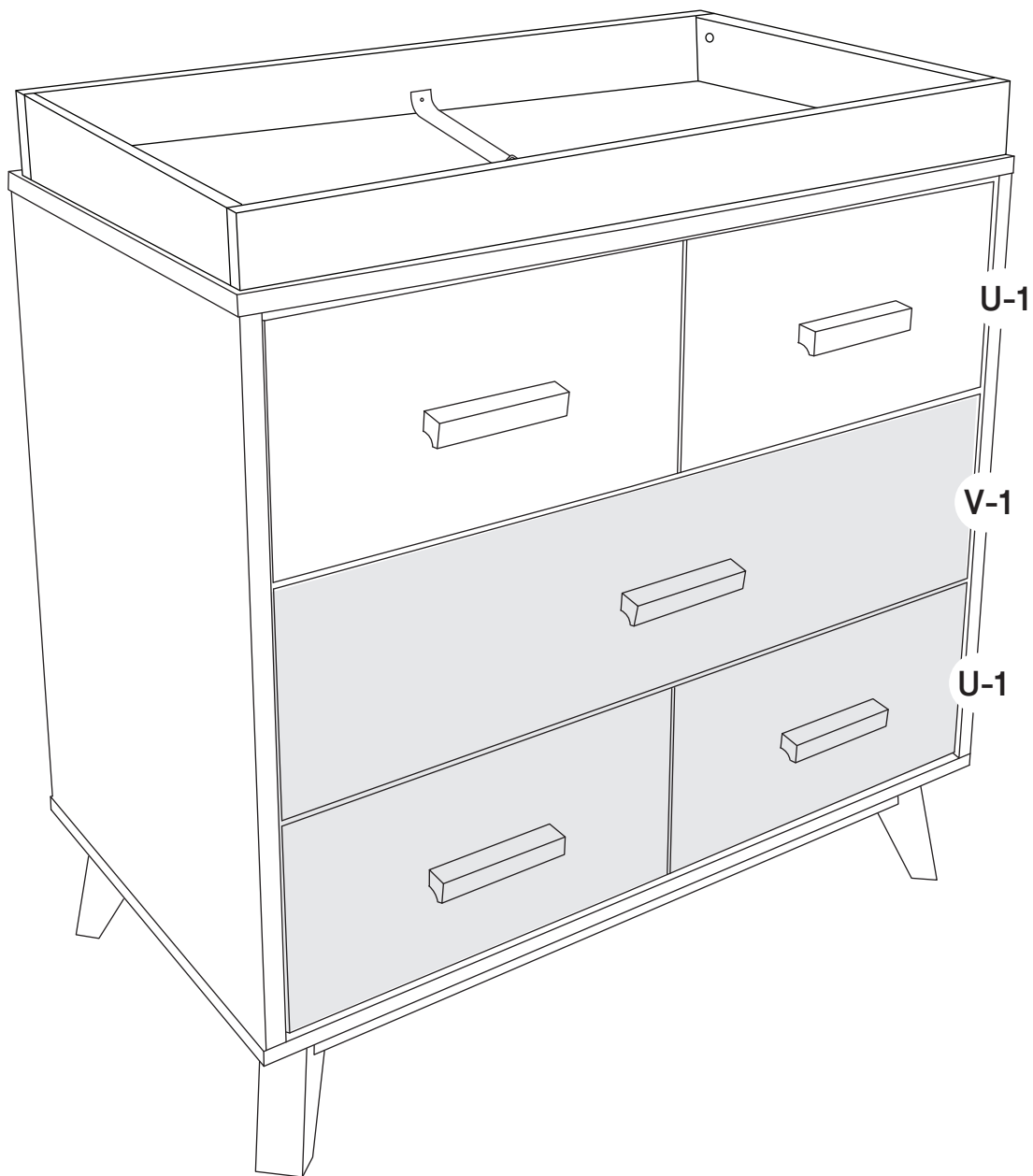

Voilà!



⚠ WARNING:

A changer pad is not included. Sold separately.

Babyletto M5319BL 31" x 16" x 4" (79 x 41 x 10 cm) contour changer pad is recommended.

⚠ ADVERTENCIA:

La almohadilla de cambio no está incluida. Se vende por separado.

Babyletto M5319BL Marco de cambiador de contorno se recomienda de 79 x 41 x 10 cm (31 x 16 x 4 pulgadas).

⚠ AVERTISSEMENT:

Le coussin à langer n'est pas inclus mais vendu séparément.

Babyletto M5319BL Le coussin à langer de 79 x 41 x 10 cm (31 x 16 x 4 PO) avec contour est recommandé.



storage

Because materials respond to temperature and humidity, it is important to store furniture in controlled environments. Furniture should not be placed in direct sunlight or near air-conditioning outlets, radiators, heaters, or humidifiers. Any changes such as extreme heat or cold, dampness, or dryness, may cause noticeable shrinkage or swelling of wood. Direct sunlight may affect the coloring of materials over time.



care and cleaning

To clean wood or metal parts, use a lint-free, soft cloth with a non-toxic cleaner. Wipe dry immediately. To avoid scratches or other damages, do not use abrasive chemicals or materials. For fabrics, we recommend using a non-toxic foaming fabric cleaner or leather cleaner where appropriate. Touch up kits are available for purchase by contacting us at:

(323) 282-5163 or INFO@MDBMAIL.COM



registration

Registering your product is simple. You can do so at:

BABYLETTO.COM/REGISTRATIONS



part replacement

If you would like to order replacement or missing parts, please visit us at:

BABYLETTO.COM/PARTS

or you can contact us by mail at:

8700 REX RD. PICO RIVERA, CA 90660



one year limited warranty

Oops! Did we make a mistake? No worries, your Babyletto product is covered under warranty for one year after the date of purchase. For more details on our warranty policy, please visit:

BABYLETTO.COM/WARRANTY

WARNING:

BEFORE USE

- Read all instructions before use of the changing table.
- Keep instructions for future use.
- Do not use changing table if it is damaged or broken.
- If a means of attachment to the contoured changing pad or add-on changing unit is provided, the instructional literature shall provide instructions on how to secure the contoured changing pad or add-on changing unit to the support surface.
- This product is not intended to be used as a changing table without adult supervision. Use of the product without this may result in death or serious injury to your child from falling. Follow all instructions on attaching and using the changing table.
- Recommended maximum weight of the occupant for which the changing table, add-on changing unit, or contoured changing pad is 30 lb (13.6 kg).

SUFFOCATION HAZARD

- Babies have suffocated while sleeping on changing areas: changing area is not designed for safe sleep. **NEVER** allow baby to sleep on changing area.

FALL HAZARD

- Children have suffered serious injuries after falling from changing areas. Falls can happen quickly.
- **STAY** in arm's reach of your child.
- **ALWAYS** secure this pad to the support surface by using the provided hardware. See instructions.



almacenamiento

Dado que los materiales responden a la temperatura y la humedad, es importante guardar muebles en ambientes controlados. No deben ponerse los muebles a la luz solar directa ni cerca de salidas de aire acondicionado, radiadores, calefactores ni humidificadores. Cualquier cambio como los extremos de calor o frío, humedad o sequedad, pueden causar notoriamente encogimiento o hinchazón en la madera. La luz solar directa puede afectar la coloración de los materiales con el paso del tiempo.



cuidado y limpieza

Para limpiar piezas de madera o metal, use un paño suave sin pelusa con un limpiador no tóxico. Seque con un paño inmediatamente. Para evitar rayar o dañar la superficie, no use agentes químicos ni materiales abrasivos. En cuanto a las telas, recomendamos usar una espuma limpiadora no tóxica para telas o un limpiador para cuero según corresponda. Hay kits para retocar disponibles para la venta contactándonos en:
(323) 282-5163 o INFO@MDBMAIL.COM



registrarse

Es sencillo registrar su producto. Puede hacerlo en:

BABYLETTO.COM/REGISTRATIONS



recambio de piezas

Si quisiera pedir repuestos o piezas faltantes, visítenos en:

BABYLETTO.COM/PARTS

o puede contactarnos por correo en:

8700 REX RD. PICO RIVERA, CA 90660



garantía limitada de un año

¡Ups! ¿Cometimos un error? No se preocupe, este producto Babyletto está cubierto por una garantía de un año a partir de la fecha de compra. Para conocer más detalles sobre nuestra política de garantía, visite:

BABYLETTO.COM/WARRANTY

ADVERTENCIA:

ANTES DEL USO

- Lea todas las instrucciones antes de usar el mudador.
- Conserve las instrucciones para uso futuro.
- No use el mudador si está dañado o roto.
- Si se incluye un medio de sujeción para la almohadilla contorneada del mudador o una unidad adicional para el mudador, la documentación incluirá instrucciones sobre cómo sujetar la almohadilla contorneada o la unidad adicional del mudador a la superficie de apoyo.
- Este producto no está destinado a usarse como mudador sin supervisión de un adulto. Si se usa el producto sin esto puede ocasionar la muerte o lesiones graves al niño debido a caídas. Siga todas las instrucciones para instalar y usar el mudador.
- El peso máximo recomendado del ocupante que use el mudador, la unidad adicional o la almohadilla contorneada del mudador es de 30 lb (13.6 kg).

PELIGRO DE ASFIXIA

- Se han asfixiado bebés mientras duermen sobre mudadores áreas: no están diseñados los productos de áreas de mudador para dormir de manera segura. **NUNCA** deje que el bebé duerma sobre el mudador área.

PELIGRO DE CAÍDA

- Los niños han sufrido lesiones graves después de caerse de mudadores áreas. Las caídas pueden ocurrir repentinamente.
- **QUÉDESE** al alcance de la mano.
- **SIEMPRE** sujete esta almohadilla al soporte superficie mediante utilizando el hardware proporcionado. Vea las instrucciones.



rangement

Compte tenu que les matériaux réagissent à la température et à l'humidité, il importe de ranger le mobilier dans des environnements contrôlés. Le mobilier ne doit pas être placé en plein soleil ni près des sorties d'air climatisé, des radiateurs, des appareils de chauffage ou des humidificateurs. Tout changement comme un froid ou une chaleur extrême, de l'humidité ou de la sécheresse pourrait causer la contraction ou le gonflement du bois. La lumière directe du soleil peut altérer la couleur des matériaux au fil du temps.



nettoyage et entretien

Pour nettoyer le bois ou les pièces métalliques, utilisez un chiffon doux sans peluche et un produit nettoyant non toxique. Essayez immédiatement. Pour éviter les égratignures ou autres dommages, veillez à ne pas utiliser des produits chimiques ou des matériaux abrasifs. Pour les tissus, il est recommandé d'utiliser un produit nettoyant pour tissus non toxique ou pour cuir le cas échéant. Il est possible de se procurer des nécessaires de retouches en nous contactant à :

(323) 282-5163 ou INFO@MDBMAIL.COM



enregistrement

L'enregistrement du produit est simple à réaliser. Il suffit d'aller sur la page :

BABYLETTO.COM/REGISTRATIONS



pièces de rechange

Pour commander des pièces de rechange ou manquantes, veuillez visiter :

BABYLETTO.COM/PARTS

ou communiquer avec nous par courriel à l'adresse :

8700 REX RD. PICO RIVERA, CA 90660



garantie limitée d'un an

Oups! Avons-nous fait un erreur? Ne vous inquiétez pas. Votre produit Babyletto est couvert par une garantie d'un an à compter de la date d'achat. Pour plus de détails sur la politique de garantie, veuillez visiter :

BABYLETTO.COM/WARRANTY

AVERTISSEMENT:

AVANT L'UTILISATION

- Veuillez lire toutes les instructions avant d'utiliser la table à langer.
- Conservez ces instructions pour une consultation ultérieure.
- N'utilisez pas la table à langer si elle est endommagée ou brisée.
- Si la table à langer dispose d'un dispositif de fixation du matelas à langer enveloppant ou d'une unité à langer d'appoint, la documentation fournie devrait expliquer comment fixer le matelas à langer enveloppant ou l'unité à langer d'appoint à la surface porteuse.
- Ce produit ne convient pas à une utilisation comme table à langer sans supervision d'un adulte. Une telle utilisation pourrait causer des blessures graves, voire mortelles à un enfant en raison des risques de chute. Suivez toutes les instructions portant sur la fixation et l'utilisation de la table à langer.
- Le poids maximal de l'enfant utilisant la table à langer, l'unité à langer d'appoint ou le matelas à langer enveloppant ne doit pas dépasser 13,6 kg (30 lb).

RISQUE DE SUFFOCATION

- Des bébés se sont étouffés pendant qu'ils dormaient sur une surface à langer : les surfaces ne sont pas conçues pour créer un environnement de sommeil sécuritaire. Ne laissez **JAMAIS** un bébé dormir sur une surface à langer.

RISQUE DE CHUTE

- Des enfants ont subi de graves blessures lors de chutes d'une surface à langer. Une chute peut se produire sans crier gare.
- **RESTEZ** toujours à portée de main de l'enfant.
- Fixez **TOUJOURS** ce matelas sur le support la surface en utilisant les accessoires de montage. Consultez les instructions.

