

# HEKMAN®

A HOWARD MILLER COMPANY  
Grand Rapids, Michigan

## INSTALLATION INSTRUCTIONS







Pattern Description 26123 side chair

**DO NOT SCALE SKETCHES**  
COPYRIGHT 1997 HEKMAN FURNITURE COMPANY

Pattern Number(s)  
26123

Drawn By  
SKY

Date  
08/30/23

PARTS			Q' TY
A		5/16*1-3/4"	1
B		5/16*3-1/2"	4
C		5/16 "	9
D		5/16 "	9
E		5/16 "	4
F		13MM	1
G		5MM	1

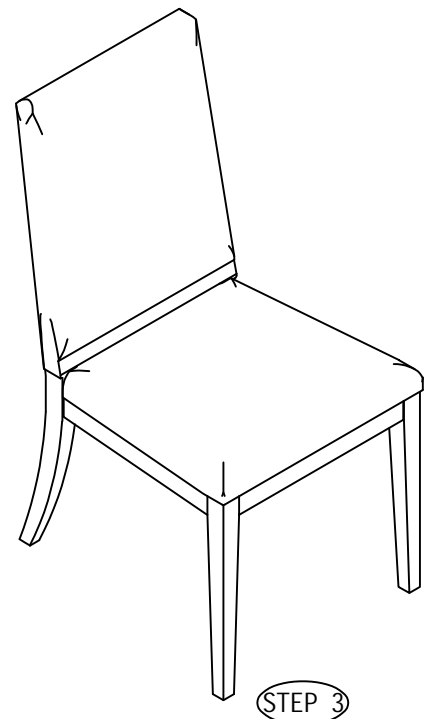
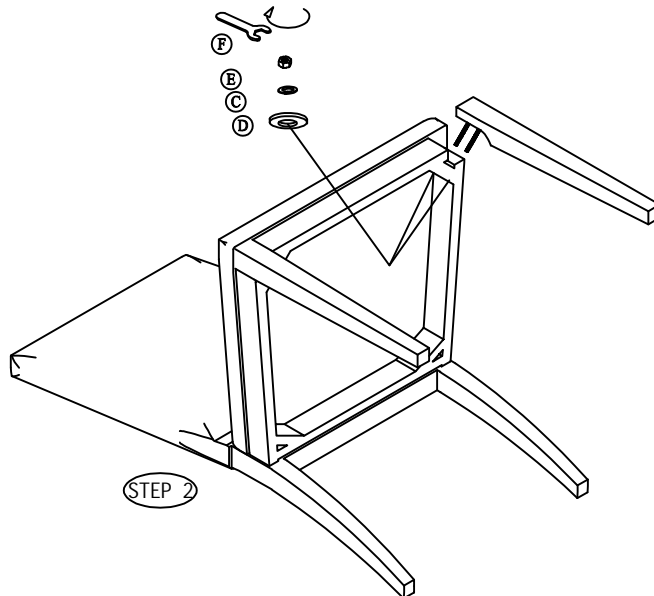
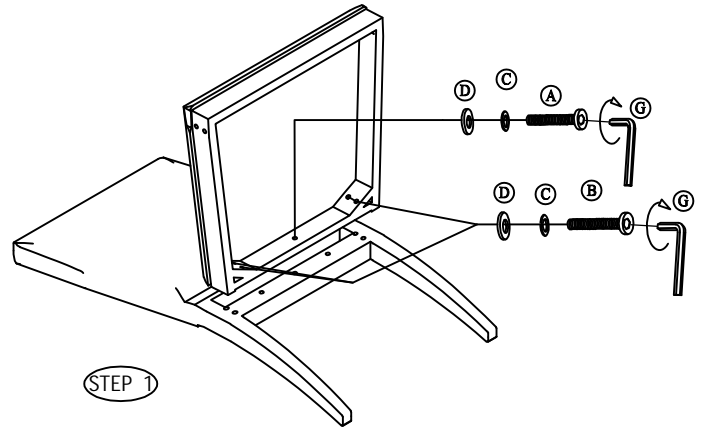

**TO ASSEMBLE:** (Two people required)

**Step 1:** Place the Chair Back on a padded surface, and assemble the Chair Seat frame to the Chair Back (as shown in Step 1), using one short bolts (A) and four long bolts (B) with five lock washers (C) and five flat washers (D) tighten with the wrench (F). Do not fully tighten any bolts until after chair has been completely assembled.

**Step 2:** Attach both front legs to the seat frame using four nuts (E), and four lock washers (C) and four flat washer (D) Tighten with the wrench (F).