

# WALKER EDISON

TM

## Spindle Solid Wood Queen Bed

SKU# BQSPIN

LOT: AAYYWW-XXX

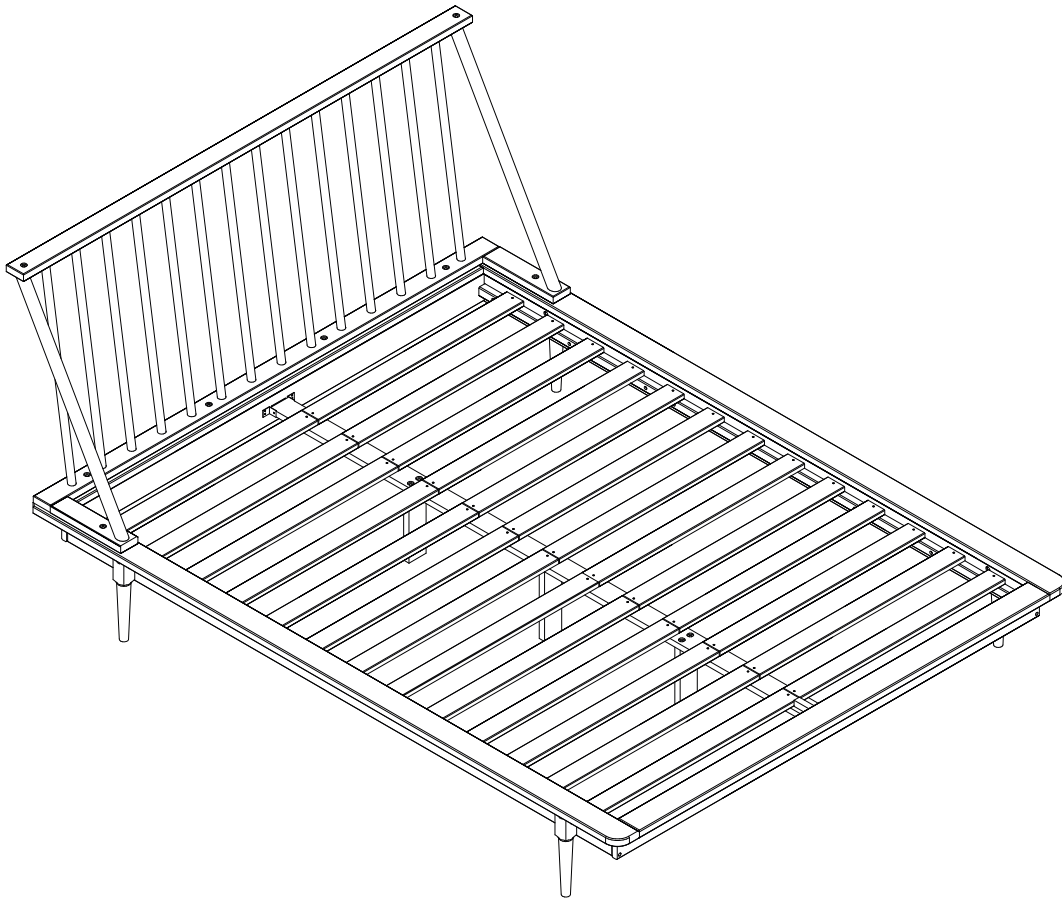

**For Residential Use Only**

Please visit our website for the most current instructions, assembly tips, report damage, or request parts. [www.walkerredison.com](http://www.walkerredison.com)

# WE Time to get started

Set up a clean and soft workplace to avoid damage during assembly. You can use the box and internal protections as a cover. It also helps to double-check if you have got all the pieces and parts before diving into the assembly.

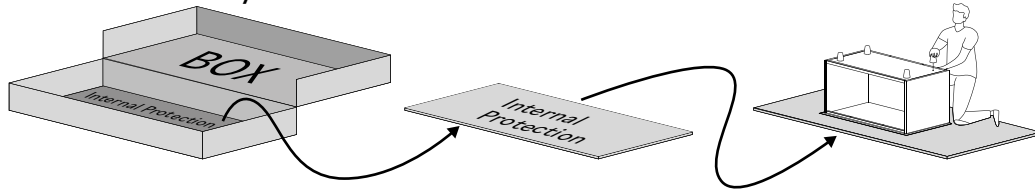

**Estimated time  
for assembly**

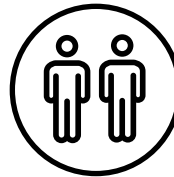

2 People Build

**People recommended  
for assembly**

Make it a team effort!  
Grab a friend for quicker,  
easier assembly.

## Tools Needed

Grab a Phillips head screwdriver  
and a hammer to conquer this  
assembly.

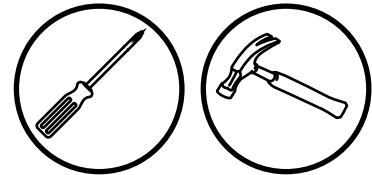

## Use power tools with caution

This furniture is made of Solid Wood and Composite Wood, soft materials. If you choose to use power tools, set it to the slower setting. Be careful! Power tools can cause cracking or damage to the furniture, they can also damage the hardware if misused.

Power tool damages are not covered by the Walker Edison warranty.

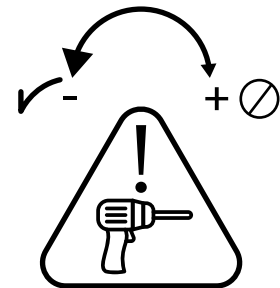

**Scan to get assembly tips and help!**

# WE Parts List

Part Number	Description	Quantity
1	Spindle	14
2	Slats	26
5	Bracket	2
6	Top rail	1
7	Bottom rail	1
13	Support beam	2
14	Spindle support	1

Part Number	Description	Quantity
15	Feet	4
20	Right side rail	1
21	Left side rail	1
23	Central foot	3
24	Central foot support	1
28	Front rail	1
29	Back rail	1

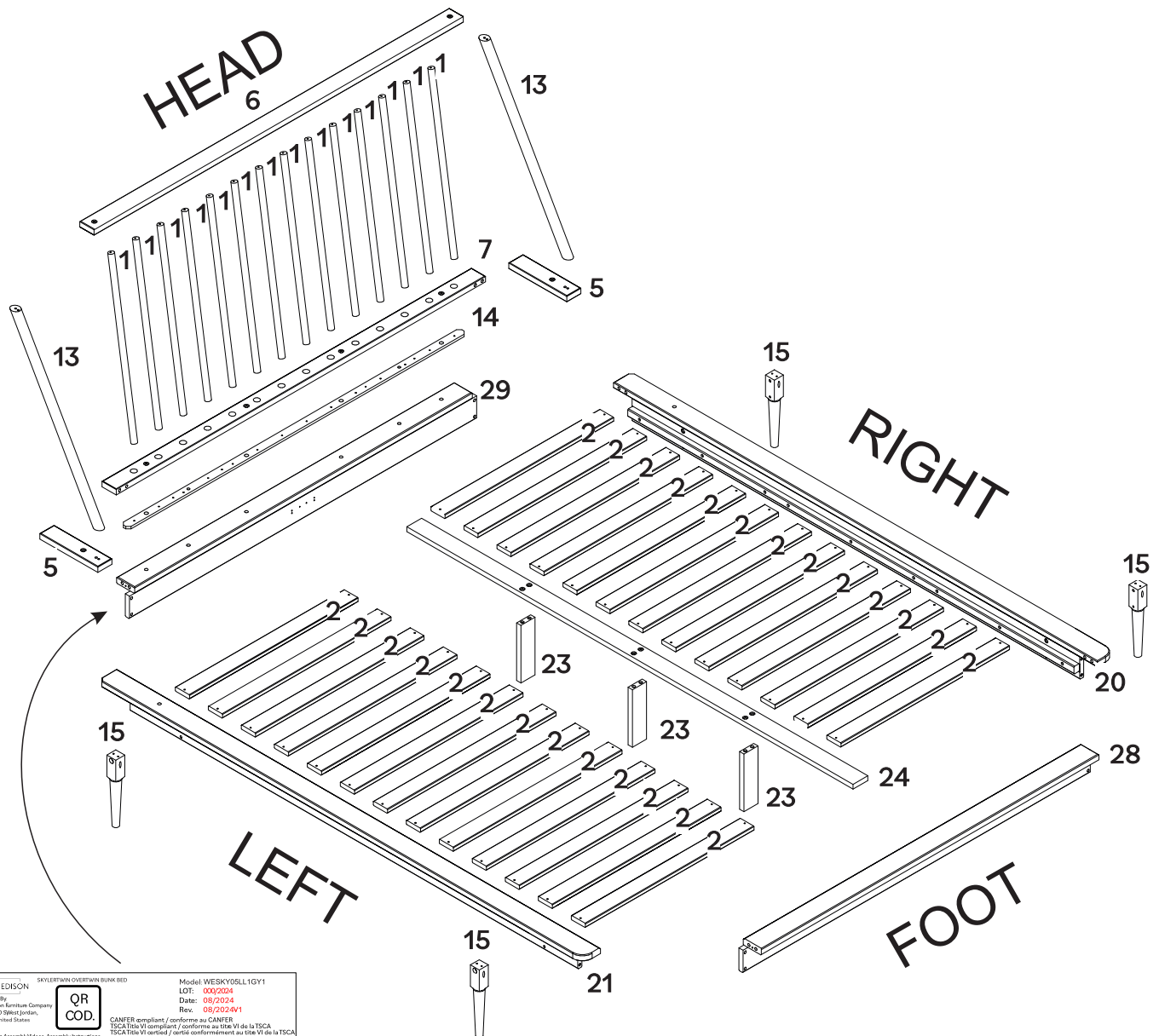





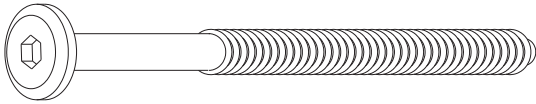

WALKER EDISON SKYLEFTMAN OVERSTAY BLUNK BED  
 Distribution By: QR COD  
 Walker Edison Furniture Company  
 1553W 9000 West Jordan, UT 84088 United States

Model: WESKYOSLL1GY1  
 LDF: 003/2024  
 Date: 08/2024  
 Rev: 08/2024V1

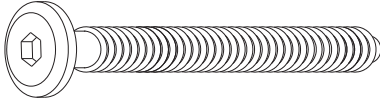
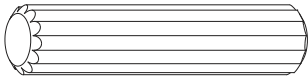
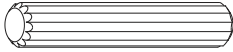
CANFER compliant / conforme au CANFER  
 TSCA Title VI compliant / conforme au titre VI de la TSCA  
 TSCA Title VI compliant / conforme au titre VI de la TSCA  
 California 93120 Compliant for Formaldehyde /  
 Conforme à la norme California 93120 pour le formaldéhyde.

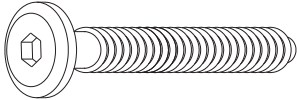
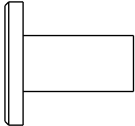
For details on Assembly/Modos, Assembly Instructions,  
 Replacement Parts and Customer Service, SCAN HERE

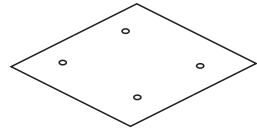
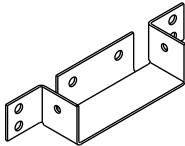
Part	Size	Name	Quantity
A 	7,0x70mm	Bolt	14
B 	3,5x30mm	Screw	94
D 	7,0x50mm	Bolt	8
E 	10x40mm	Wooden dowel	14
F 	6x30mm	Wooden dowel	4
J 		Hex key	2
L 	83mm	Spacer	2
M 	1/4x40mm	Bolt	10
N 	1/4mm	Union	10
P 	4,0x16mm	Screw	28
Q 		Metal Plate Connector	2
R 		Support	2

*The hardware quantities listed above are required for proper assembly.*

*Extra hardware pieces may be included.*

# Step 1

Let's get started! Insert Wooden Dowels (E) into Bracket (5), Front Rail (28) and Back Rail (29). Also insert Wooden Dowels (F) into Support Beam (13).

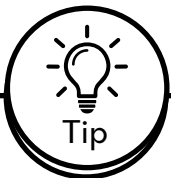
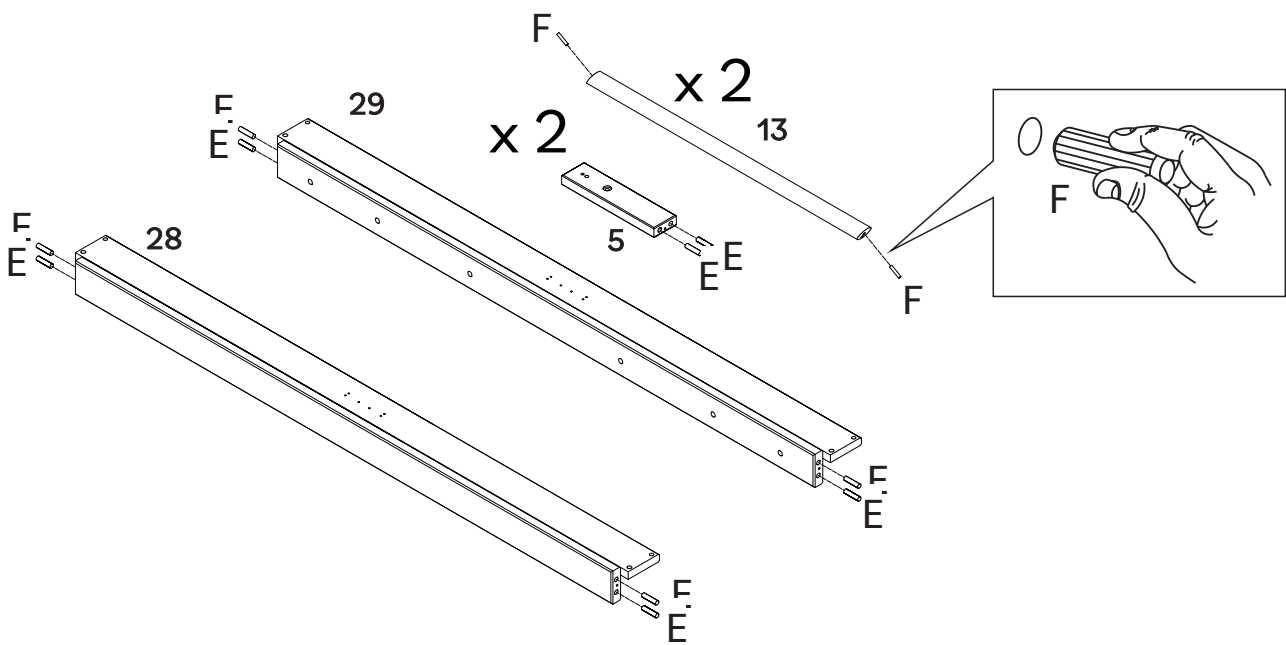

To keep your product looking its best and scratch-free, try assembling it on a soft surface like carpet or a blanket. This helps prevent any accidental scratches and keeps your furniture in top shape!

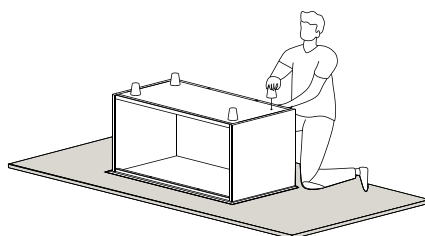

# Step 2

Attach Support (R) to Front Rail (28) and Back Rail (29) using Screw (P) and a Phillips head screwdriver.

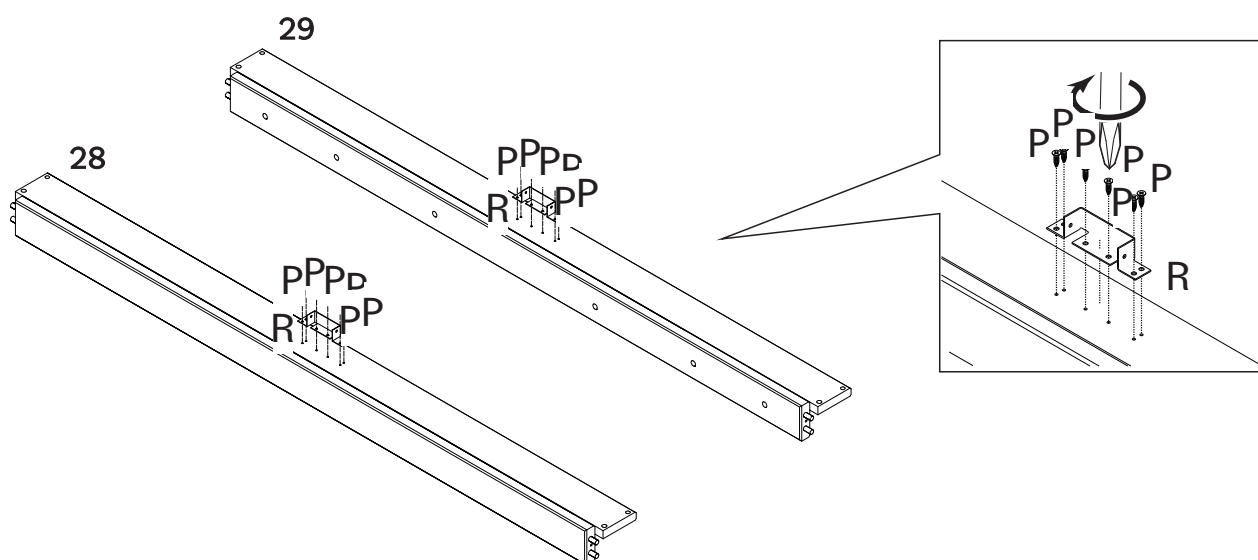
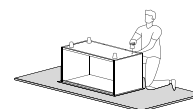

# Step 3

Secure Central Foot (23) to Central Foot Support (24) using Bolt (A) and Hex Key (J).

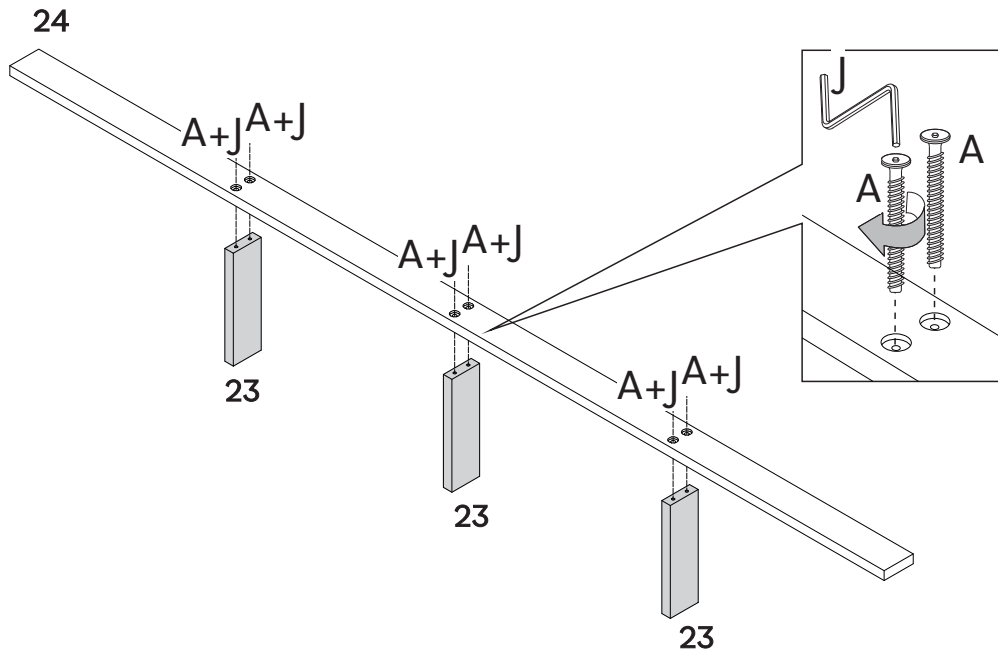
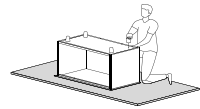
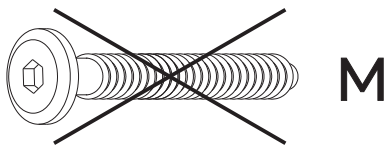
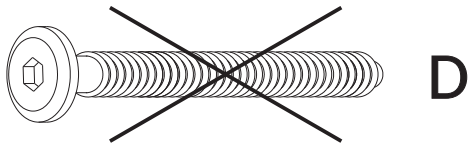
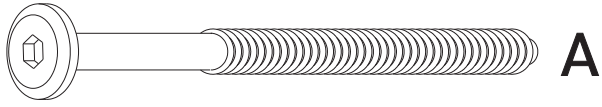

# Step 4

Join Right Side Rail (20) and Left Side Rail (21) to Front Rail (28) and Back Rail (29).

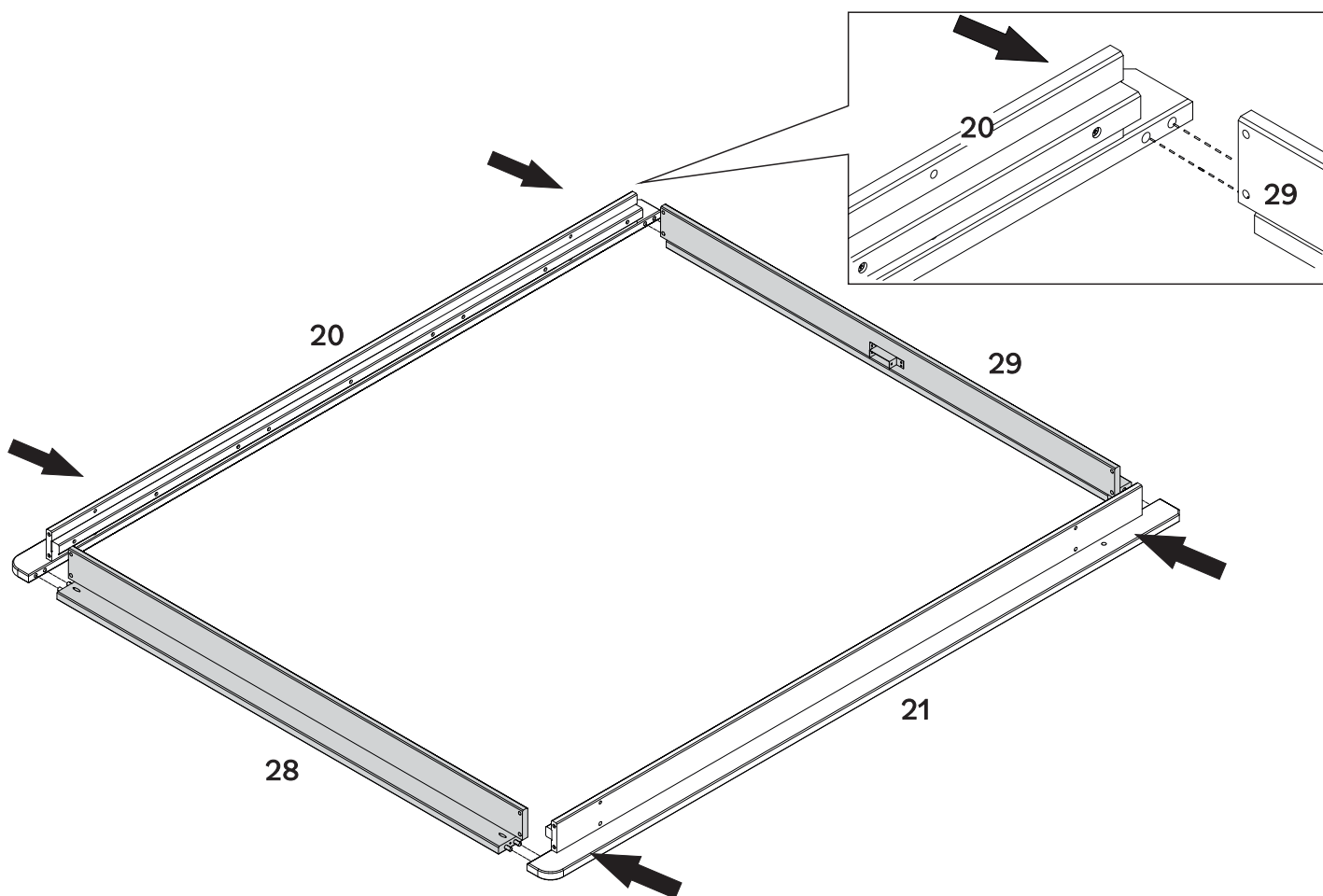



# Step 5

Secure the parts you just joined using Bolt (A) and Hex Key (J)

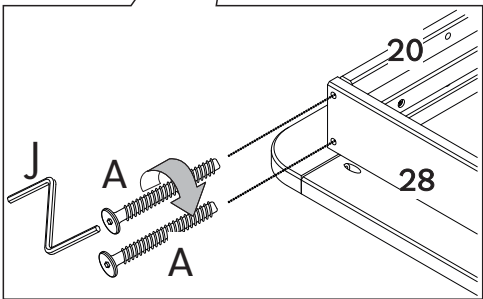
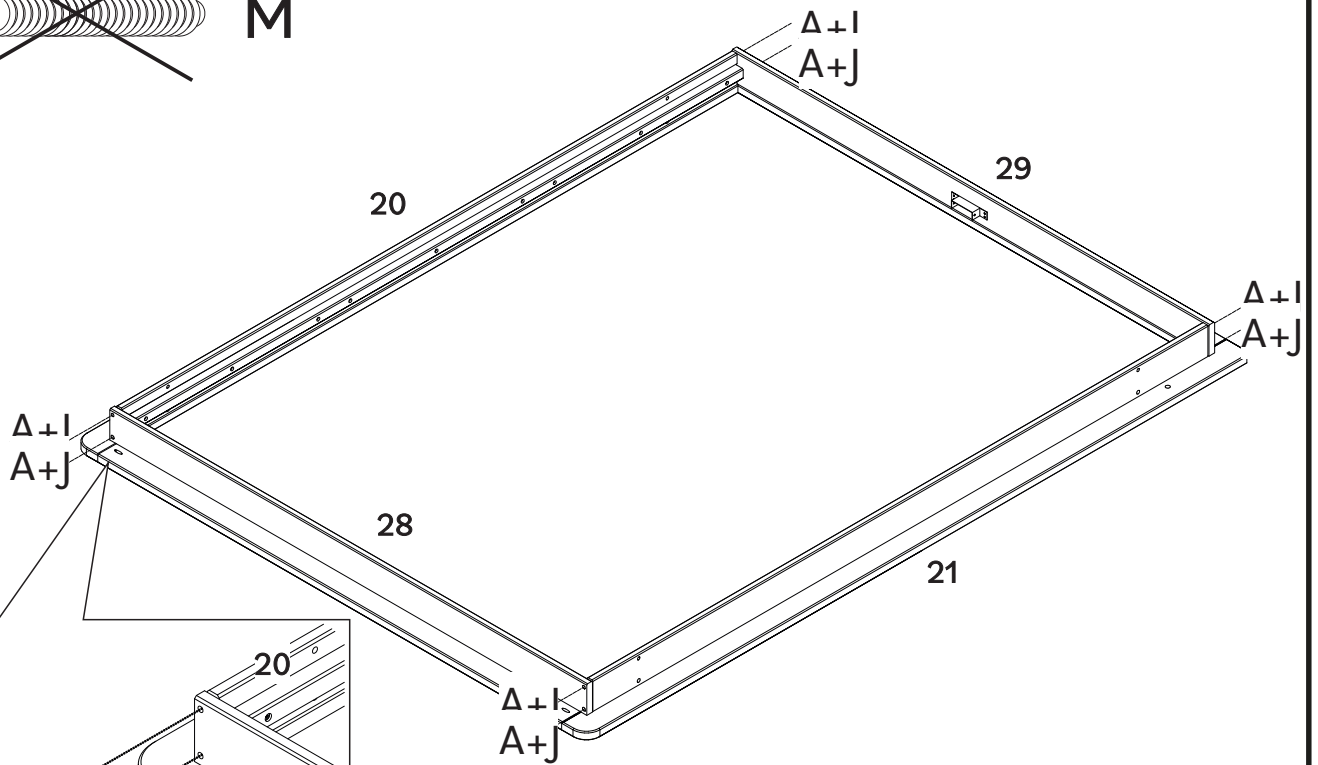
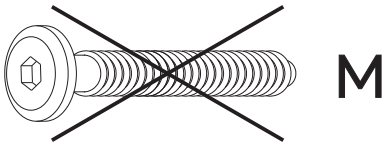
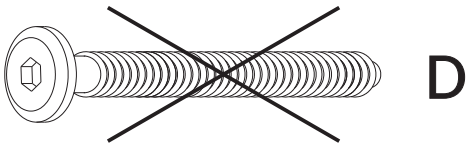
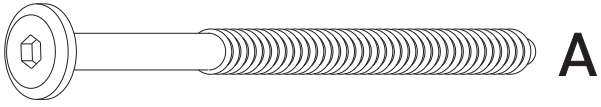

# Step 6

Also use Screw (B) and a Phillips head screwdriver to attach Right Side Rail (20) and Left Side Rail (21) to Front Rail (28) and Back Rail (29).

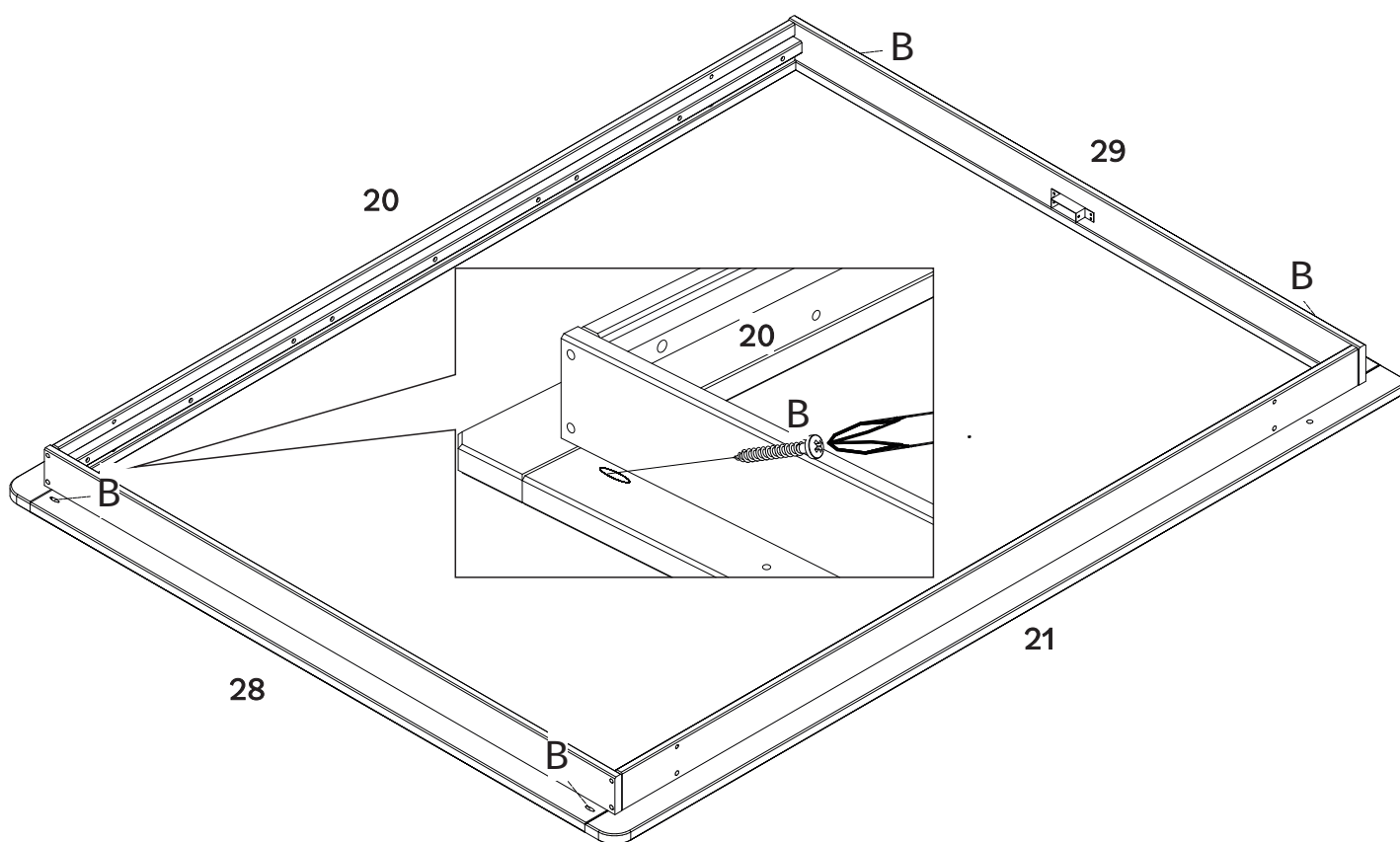

# Step 7

Assemble the Feet (15) to Right Side Rail (20) and Left Side Rail (21) using Bolt (M), Union Bolt (N) and Hex Key (J). Union Bolt has to be on the inside of the Side Rails (20,21) and Bolt (M) on the outside of the Feet (15). Also use Bolt (D) and Hex Key (J) to secure the Feet (15).

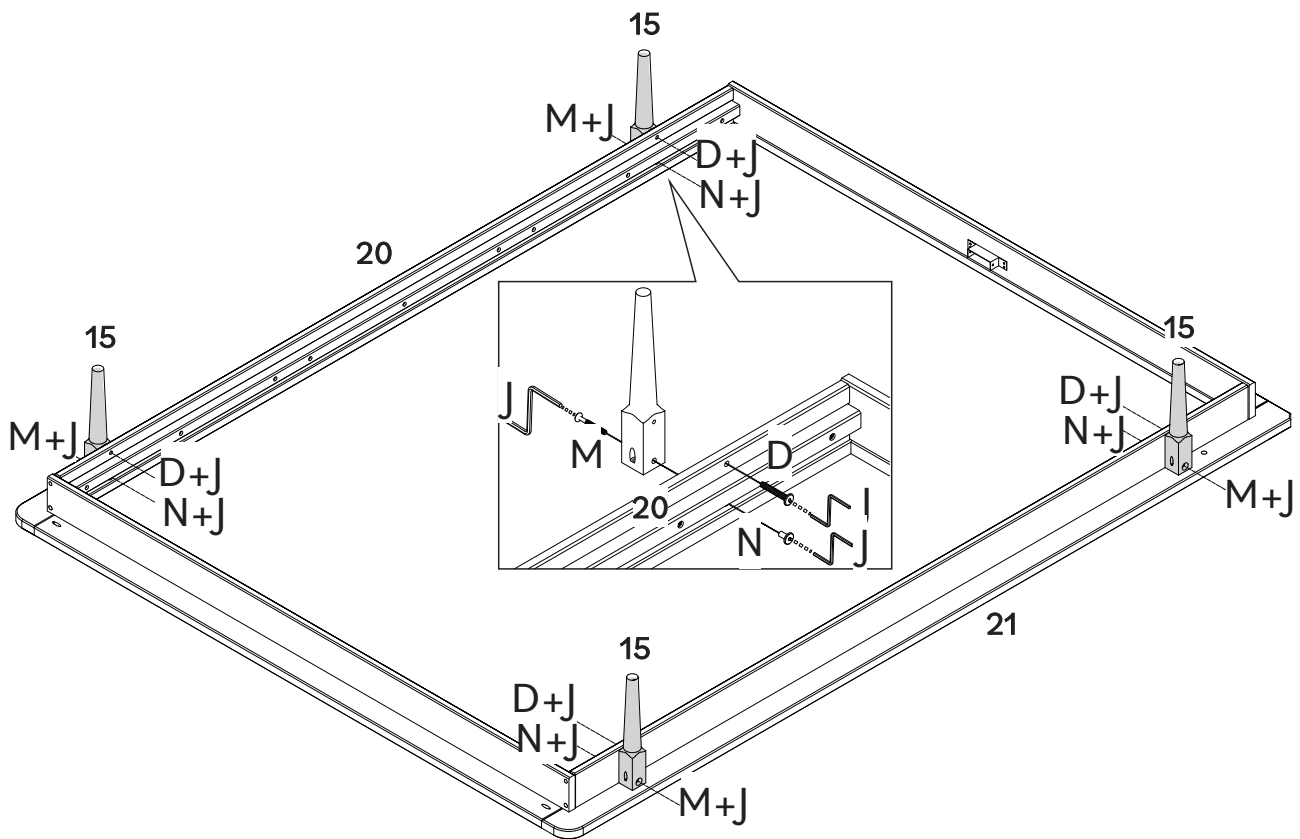

# Step 8

Finish attaching the Feet (15) using Screw (B) and a Phillips head screwdriver.

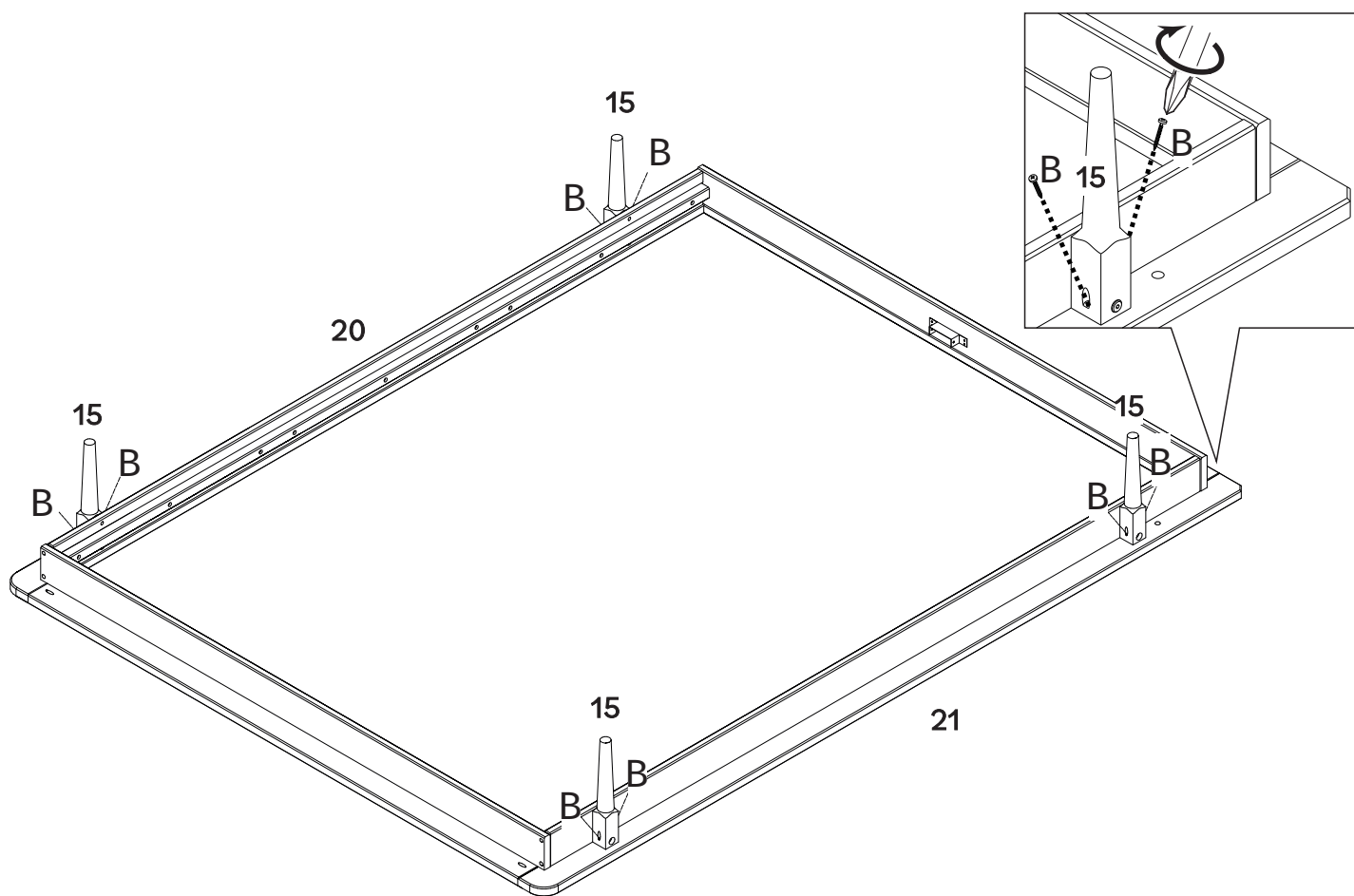

# Step 9

Attach Metal Plate Connector (Q) on the division between Side Rails (20,21) and Front Rail (28) using Screw (P) and a Phillips head screwdriver.

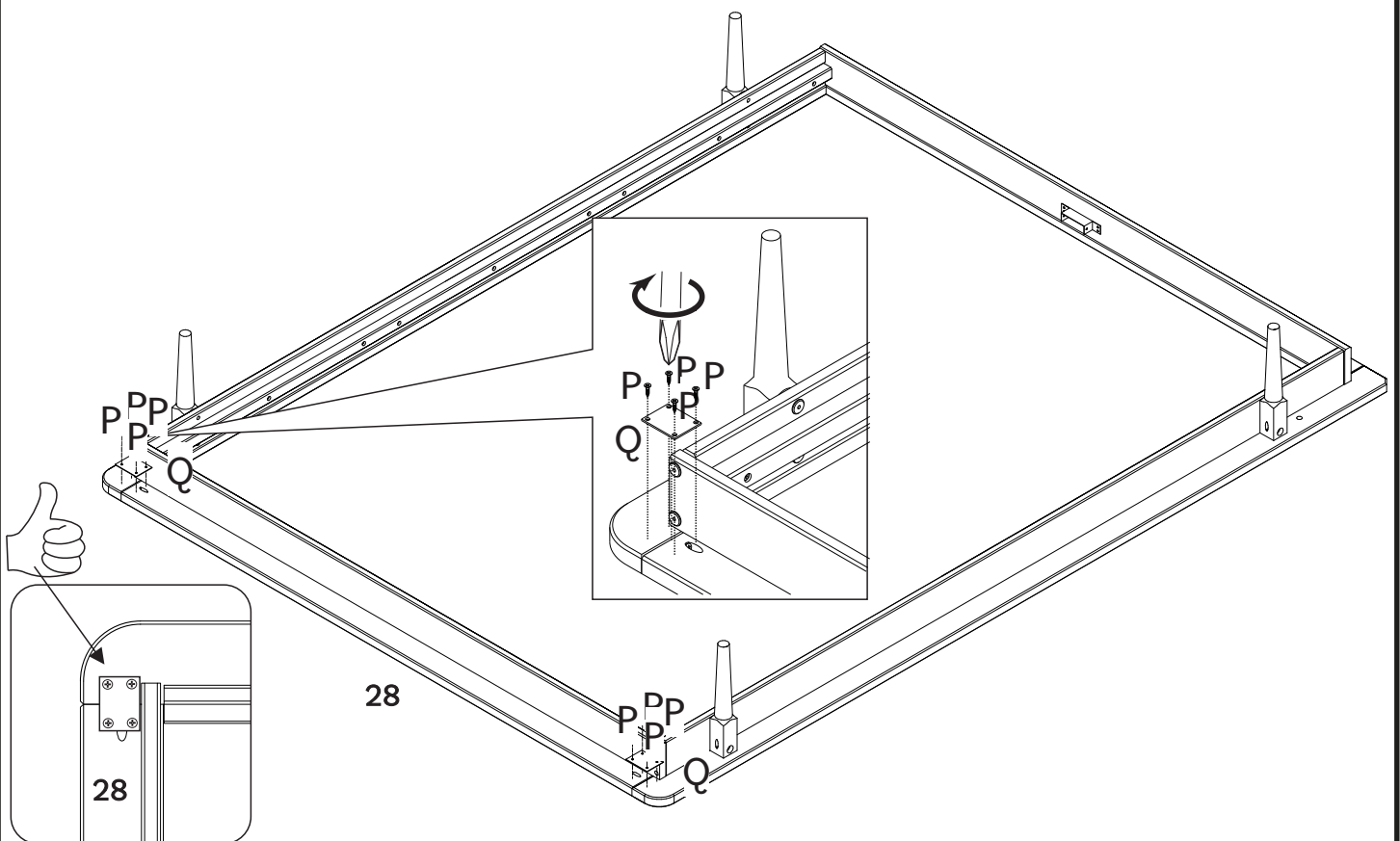

# Step 10

Secure Crossbar (24) to Support (R) using Screw (P) and a Phillips head screwdriver.

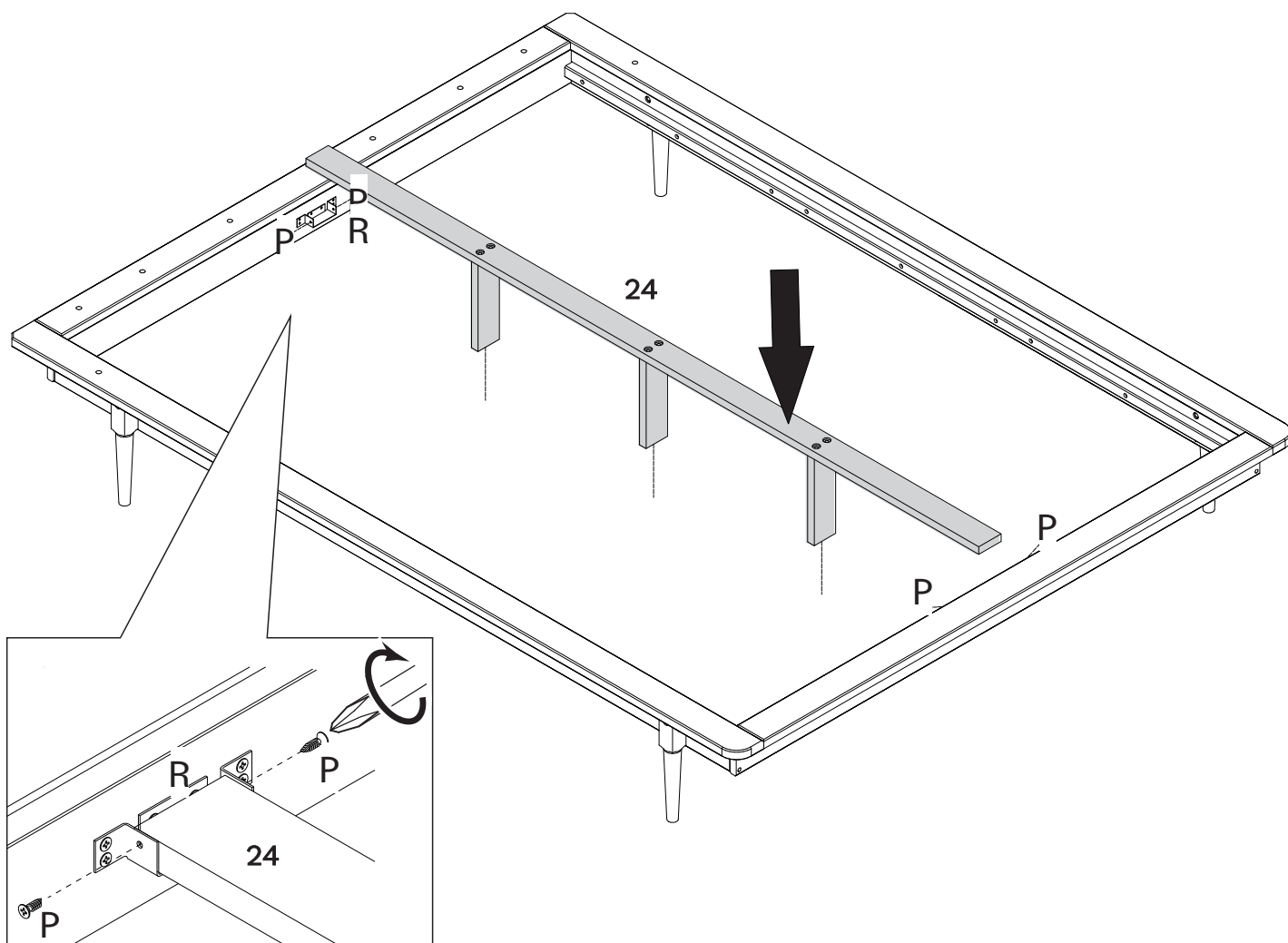

# Step 11

Place the Slats (2) on the rails and support. Use Spacer (L) to set the distance between slats, after that secure using Screw (B) and a Phillips head screwdriver.

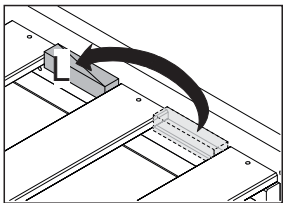
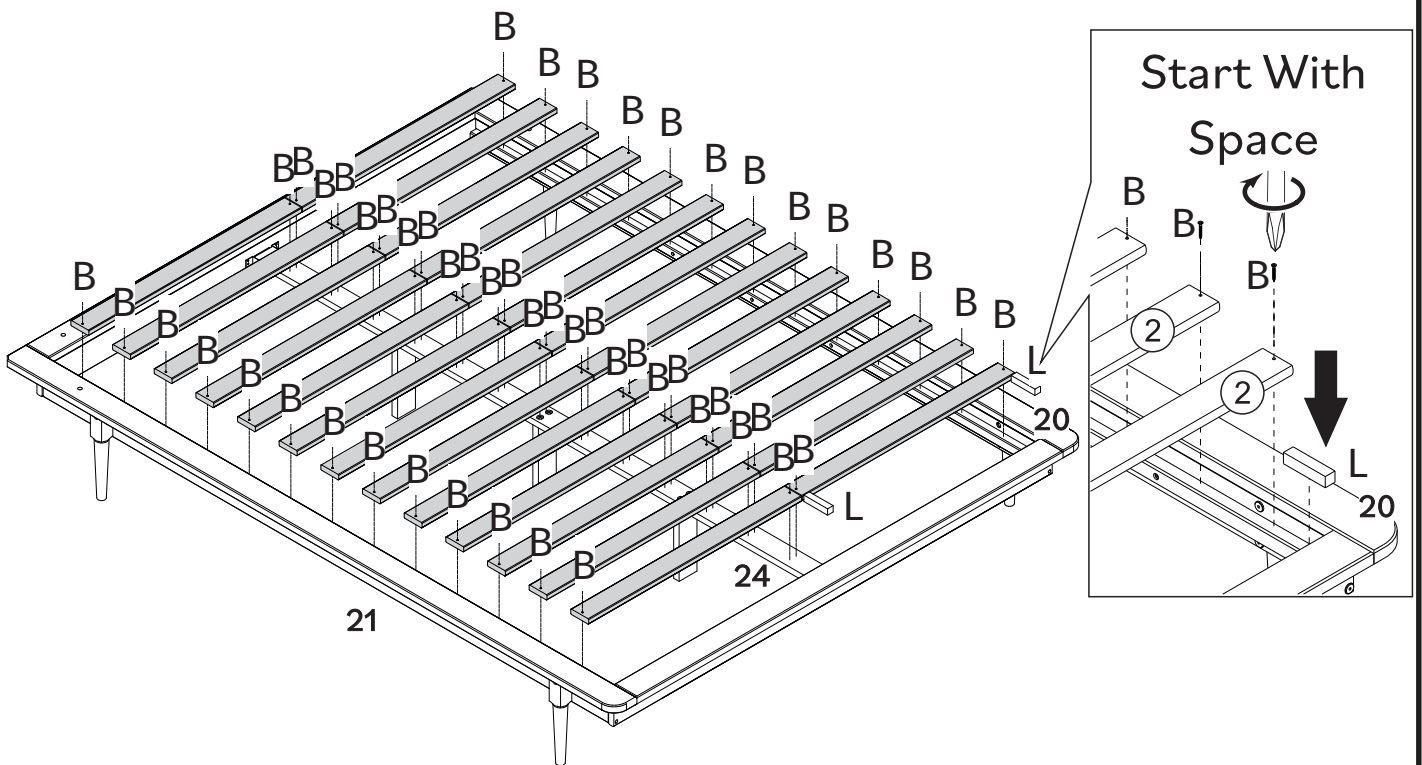

# Step 12

Let's start to assemble the headboard! Connect Bracket (5) to Bottom Rail (7). Pay attention to the side that the pocket hole must be. Attach it using Screw (B) and a Phillips head screwdriver.

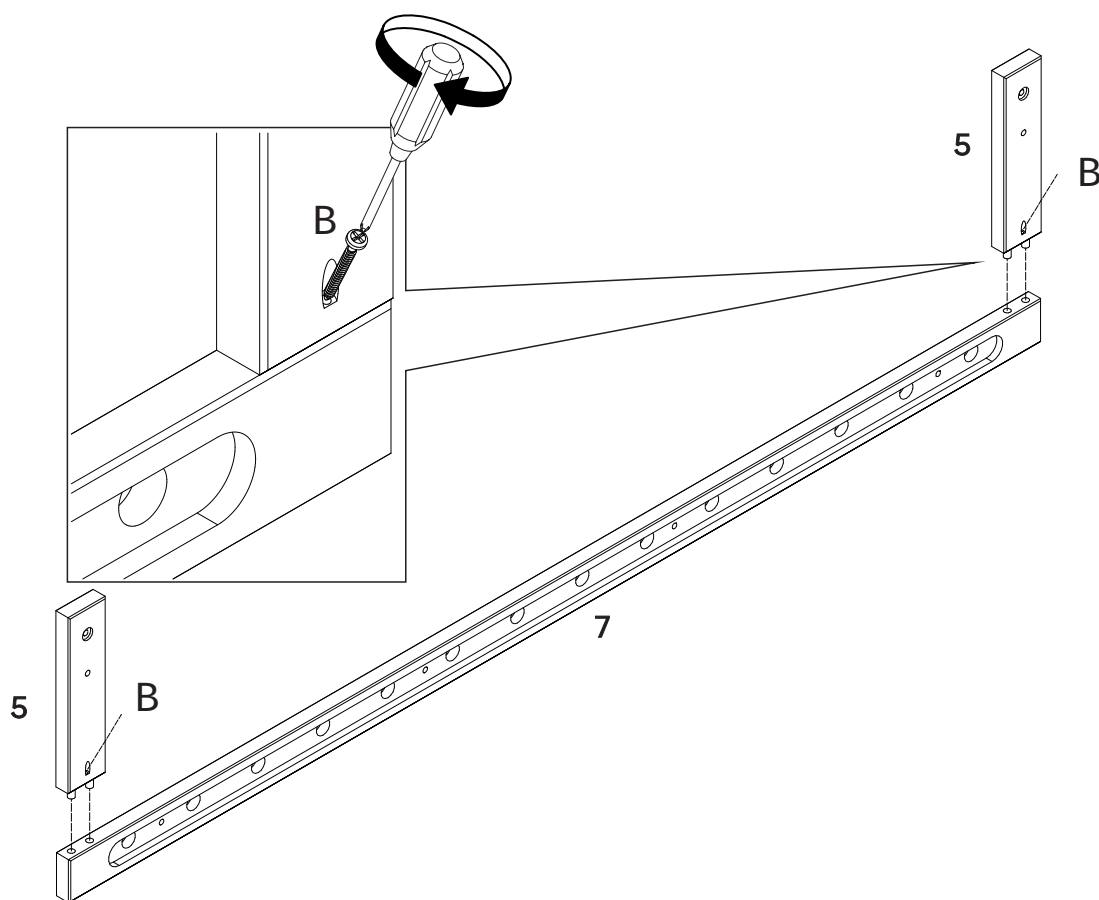



# Step 13

Join Support Beam (13) to Top Rail (6) using Bolt (D) and Hex Key (J).

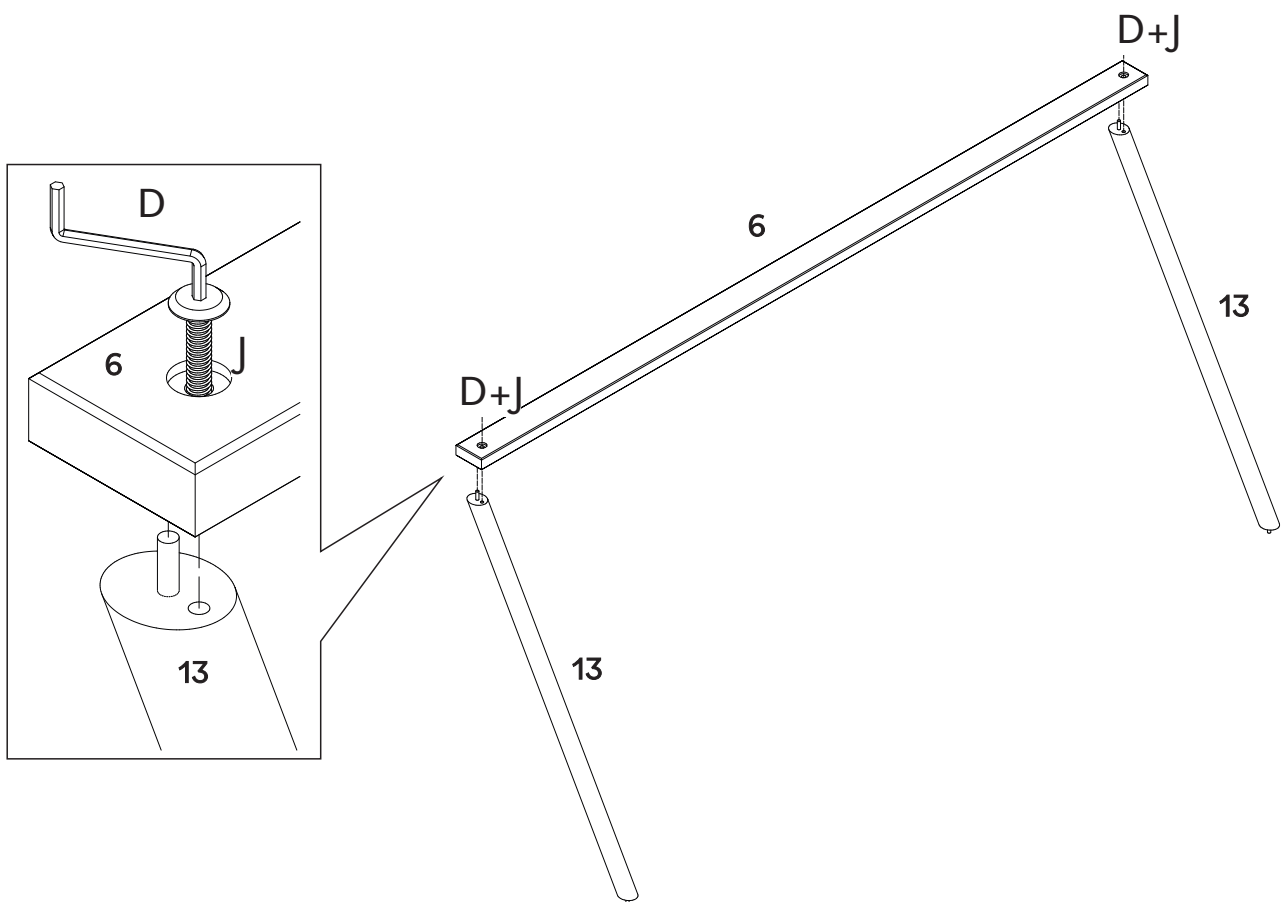

# Step 14

Fit Support Beam (13) to Bracket (5) and secure using Screw (D) and Hex Key (J).

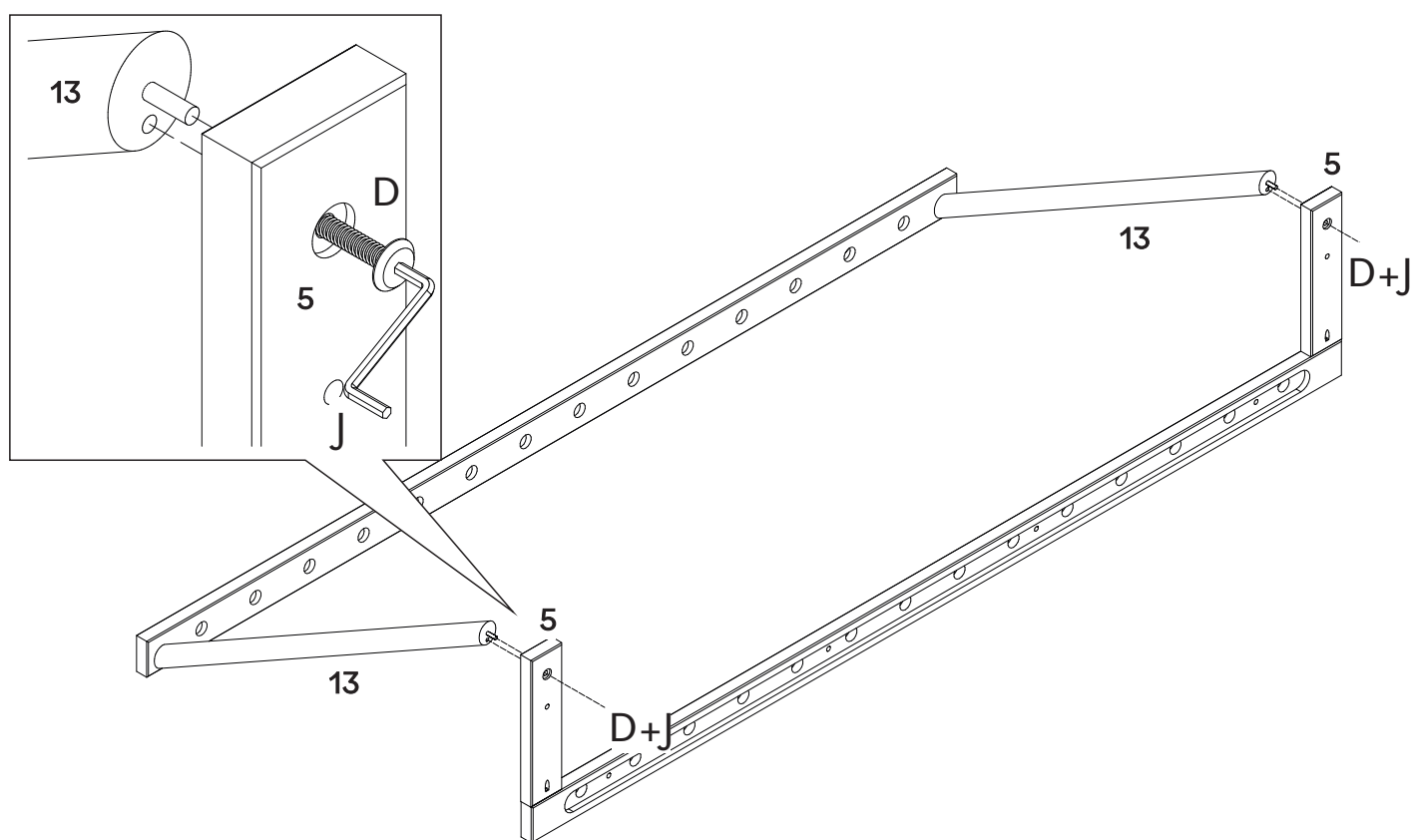

# Step 15

Insert Spindles (1) in the holes on Bottom Rail (7) fitting in Top Rail (6) and securing with Screw (B) and a Phillips head screwdriver.

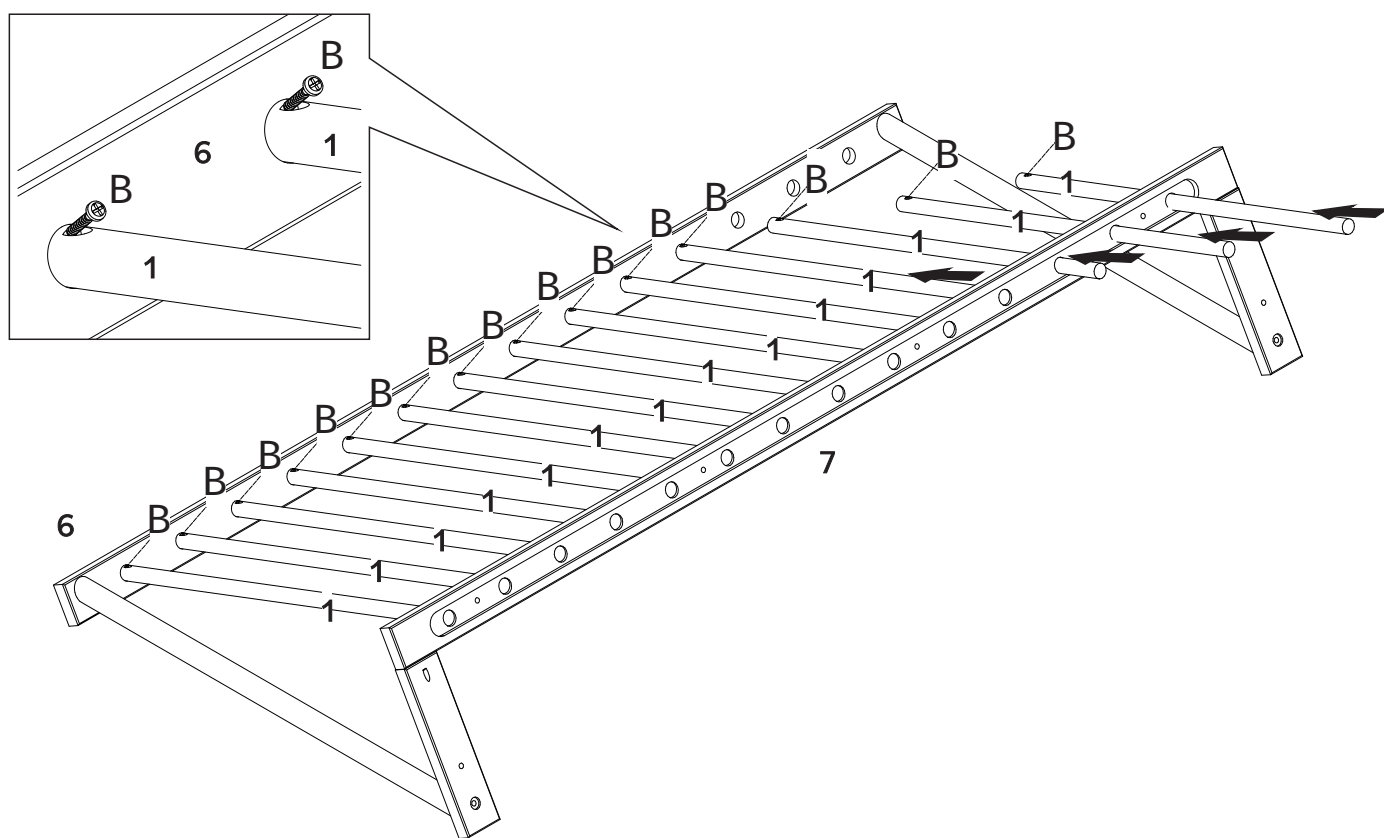

# Step 16

Insert Spindle Support Rail (14) into Bottom Rail (7) and attach with Screw (P) and a Phillips head screwdriver.

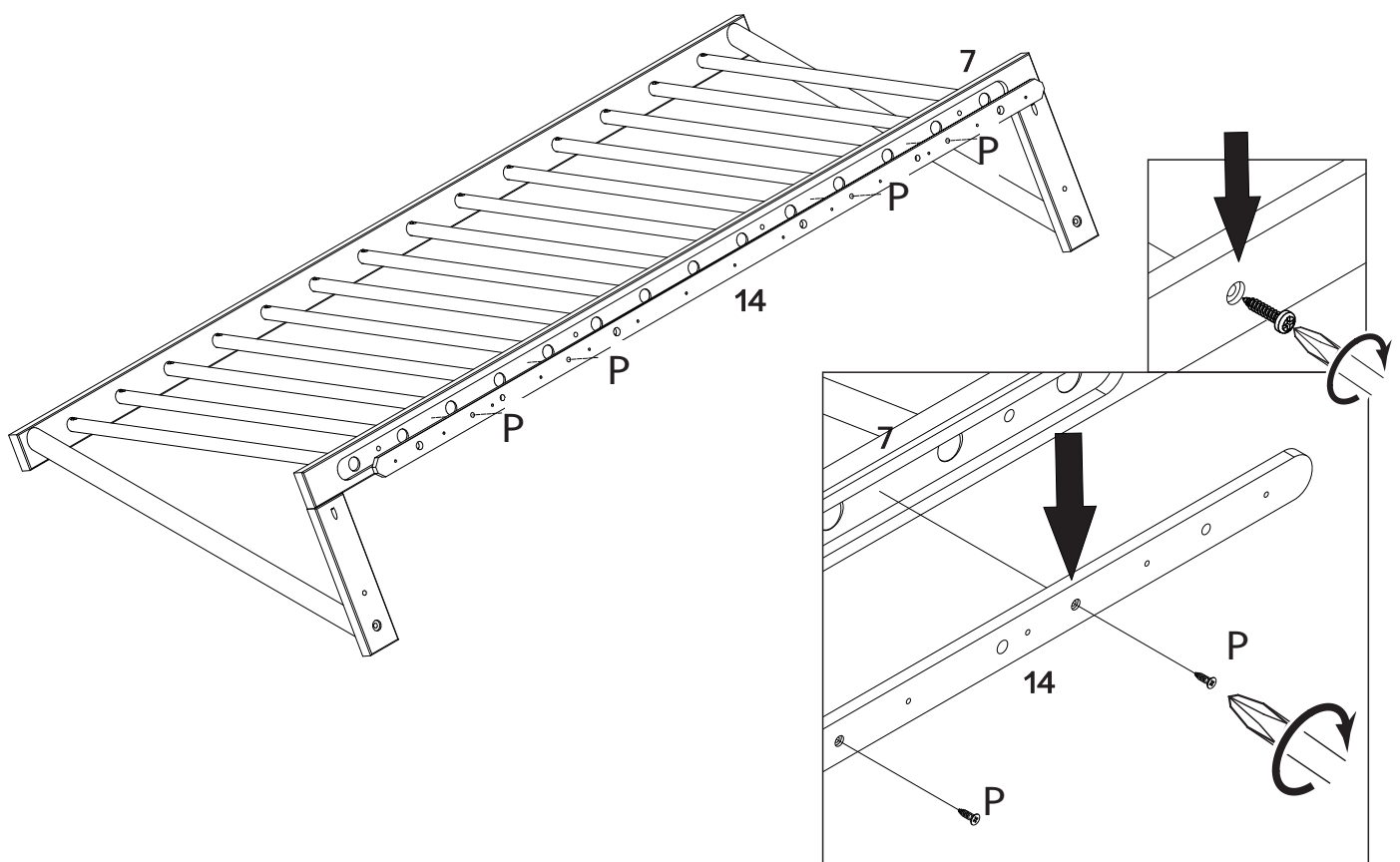

# Step 17

Use Screw (B) to secure the Spindles (1) to Spindle Support Rail (14).

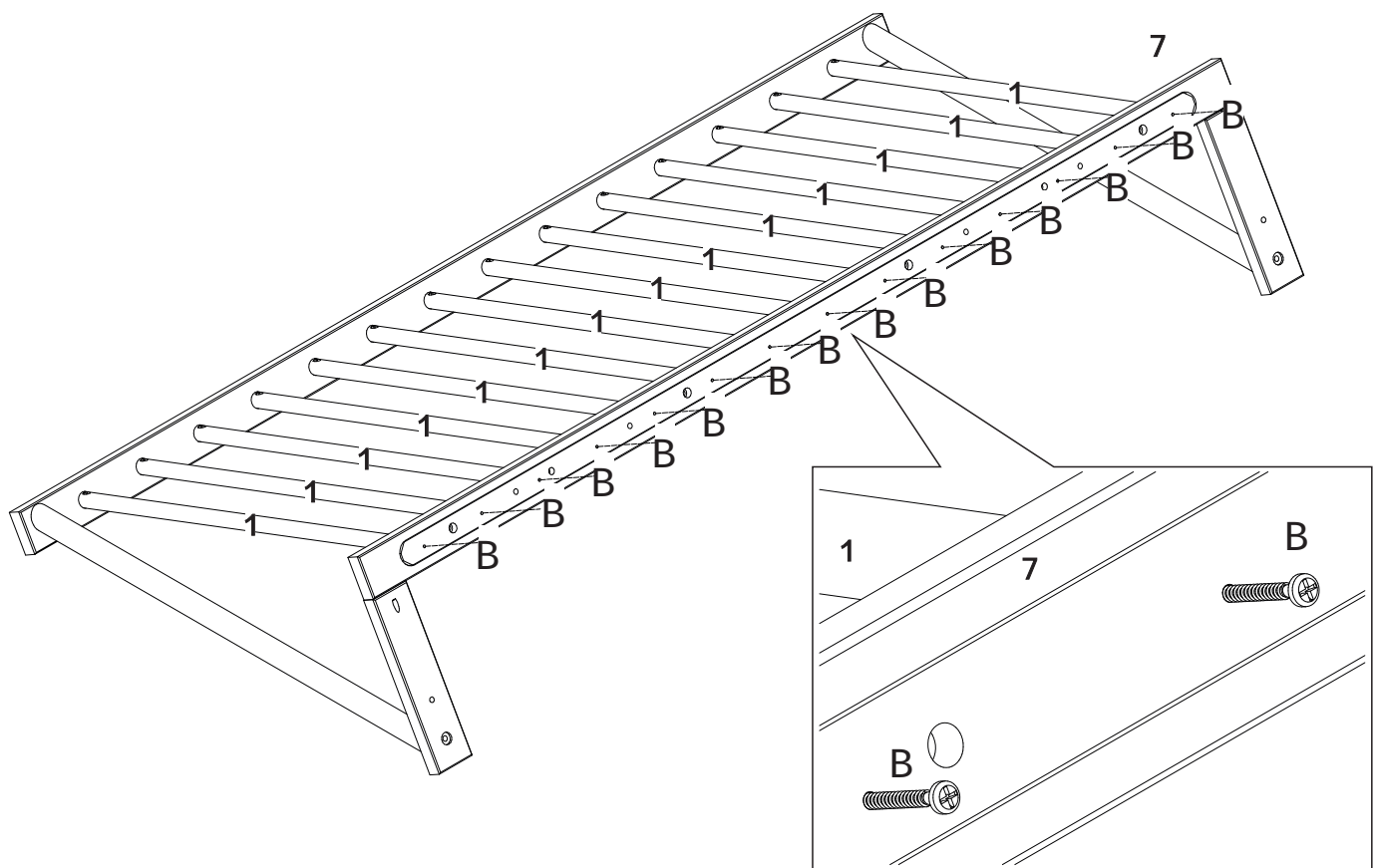

# Step 18

Insert Wooden Dowels (E) into Spindle Support Rail (14)

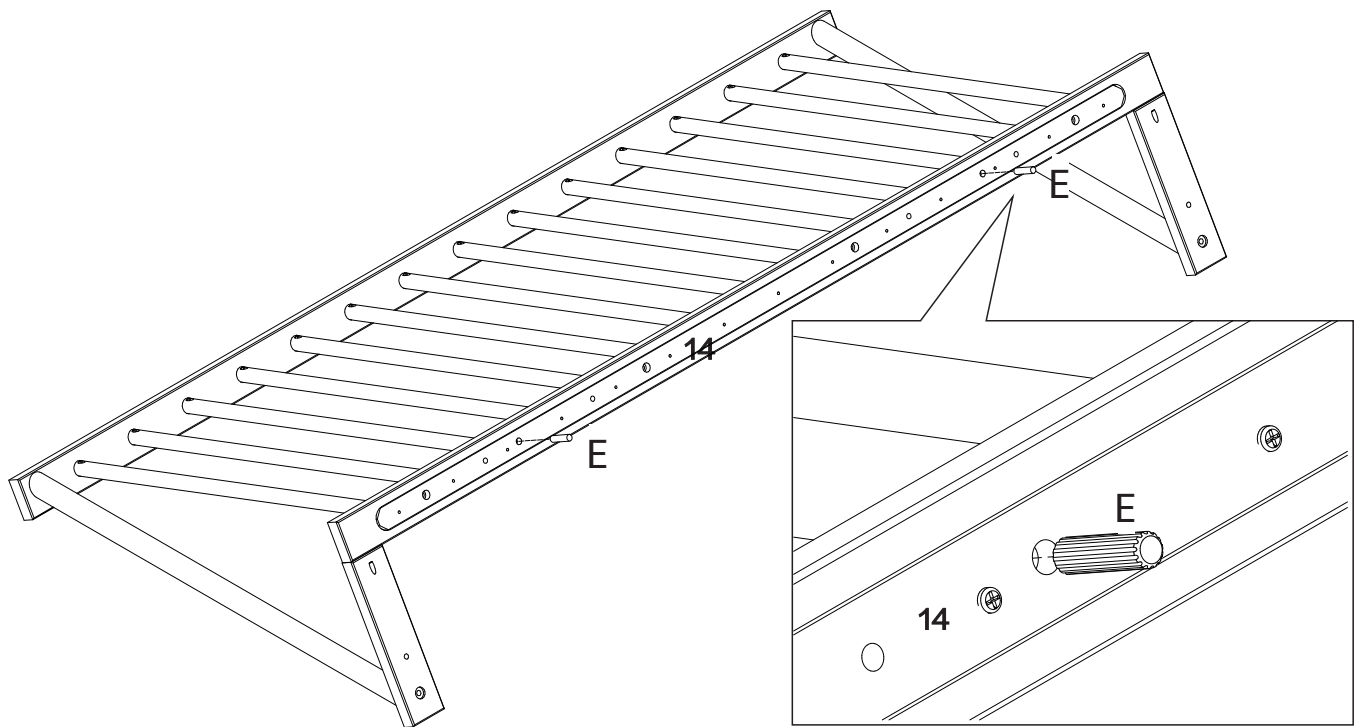

# Step 19

Use Wooden Dowels (E) as guide to join assembled headboard and bed. Press the parts together firmly.

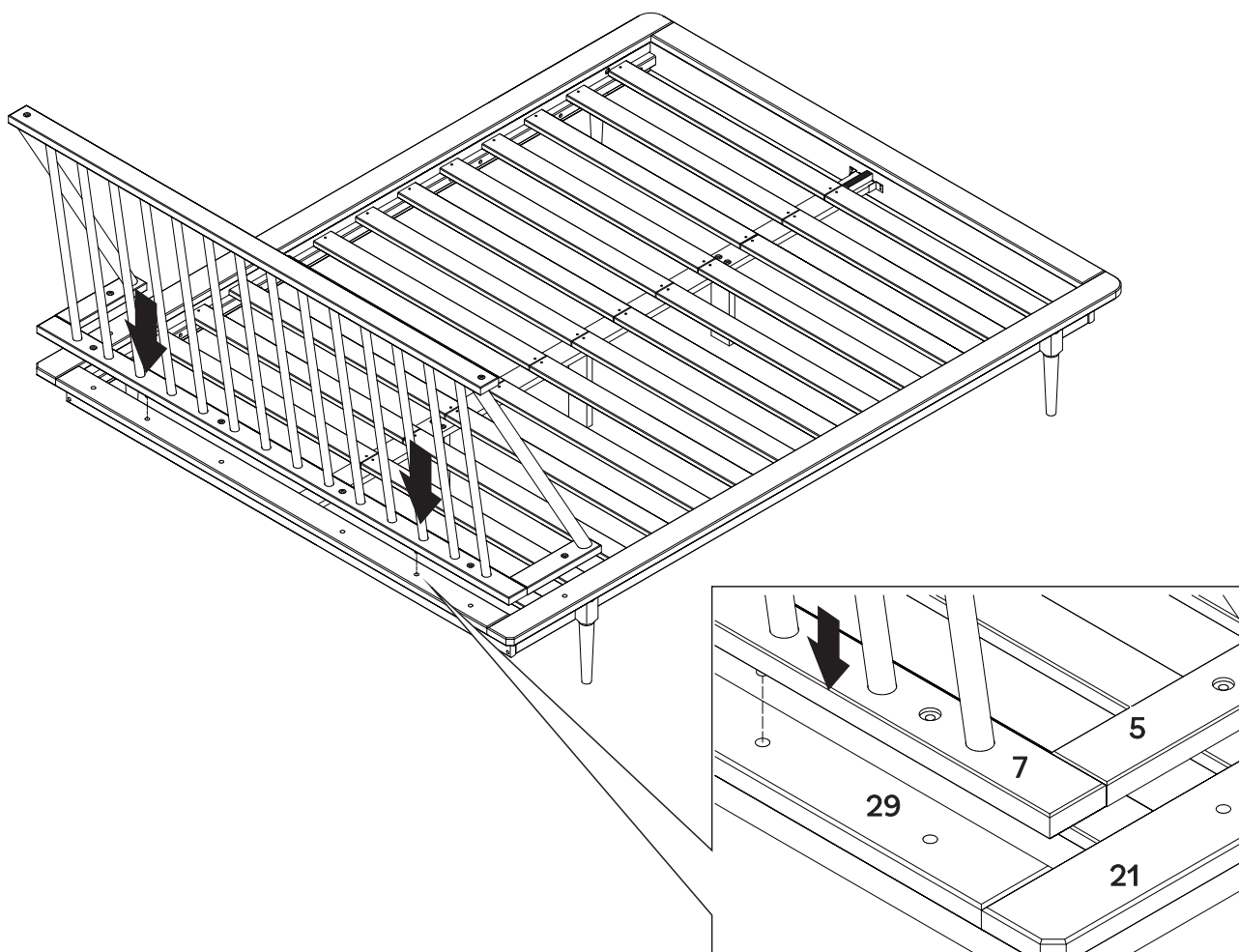

# Step 20

Secure both parts together using Bolt (M), Union (N) and Hex Key (J).

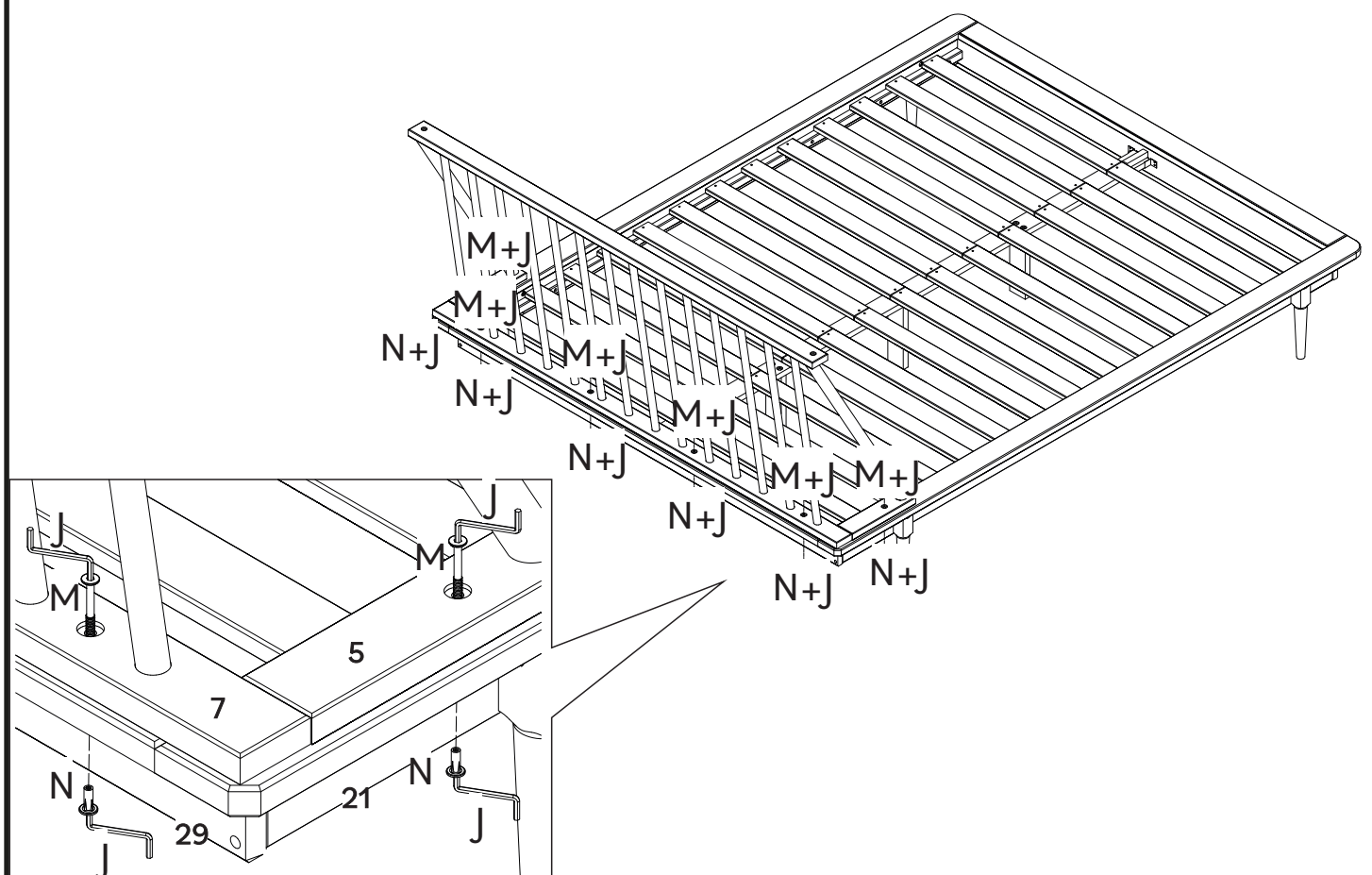



# You did it! Enjoy your new Bed!

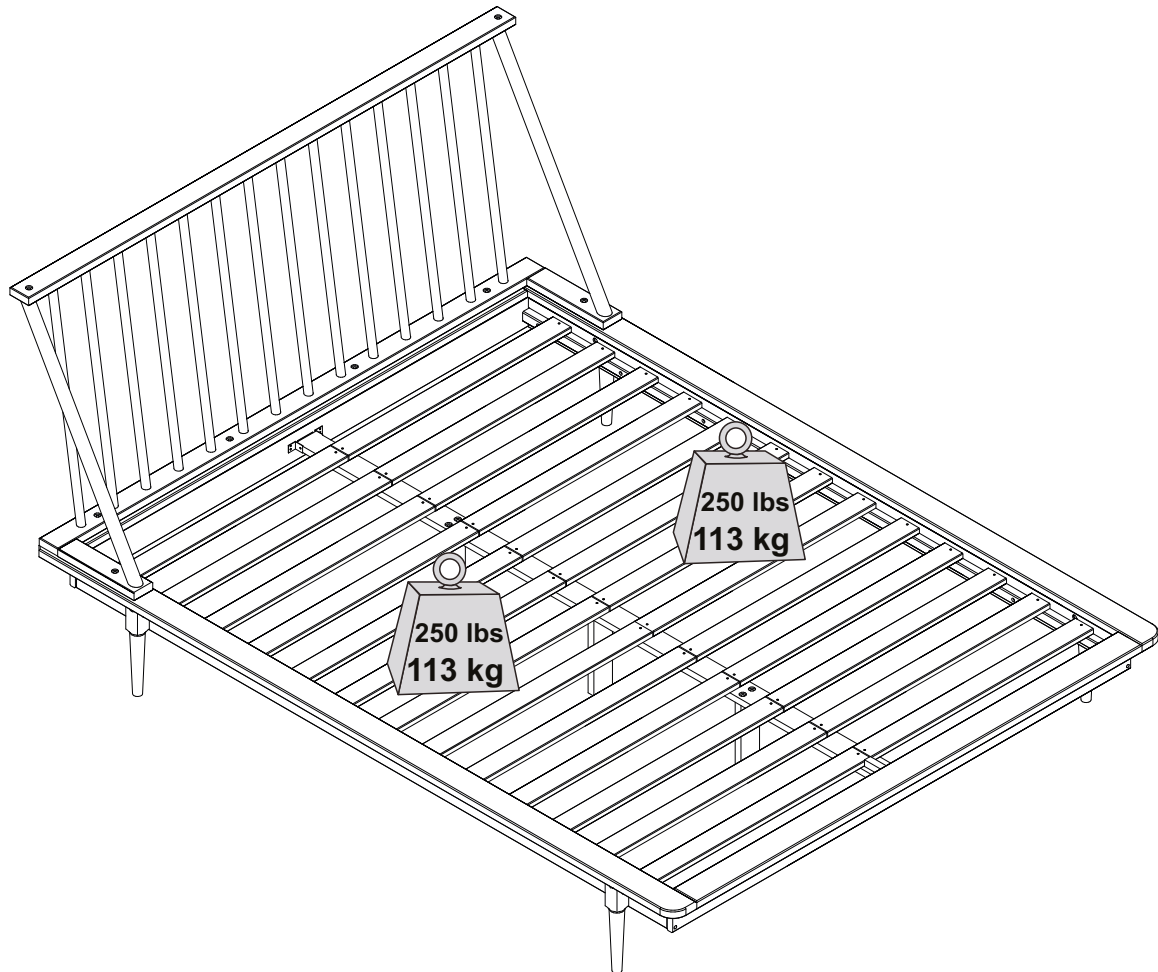

Congratulations on your new piece of furniture! We would love to hear about it and see it. Please leave us a review or post a picture with #mywalkerredisonhome

# Assembling furniture can be tricky sometimes.

Our customer service team, located in Utah, is here for product information, help assembling a product, or for any other customer support issue

Call us at **801-433-3008**

Email us at [service@walkeredison.com](mailto:service@walkeredison.com)

Visit our Customer Service website at [walkeredison.com/pages/customer-service](http://walkeredison.com/pages/customer-service)

We are available to help Monday - Thursday 8am-5pm, Friday 8am-3pm

For details on Assembly Videos, Assembly Instructions, Replacement Parts, and Customer service,

**SCAN HERE**

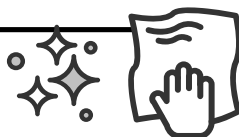

For cleaning, never use abrasives, use a soft cloth and water with neutral soap to clean the furniture.

# WALKER EDISON™

## Spindle Bois Maçif Queen Lit

## Spindle Cama Queen de Madera Maciza

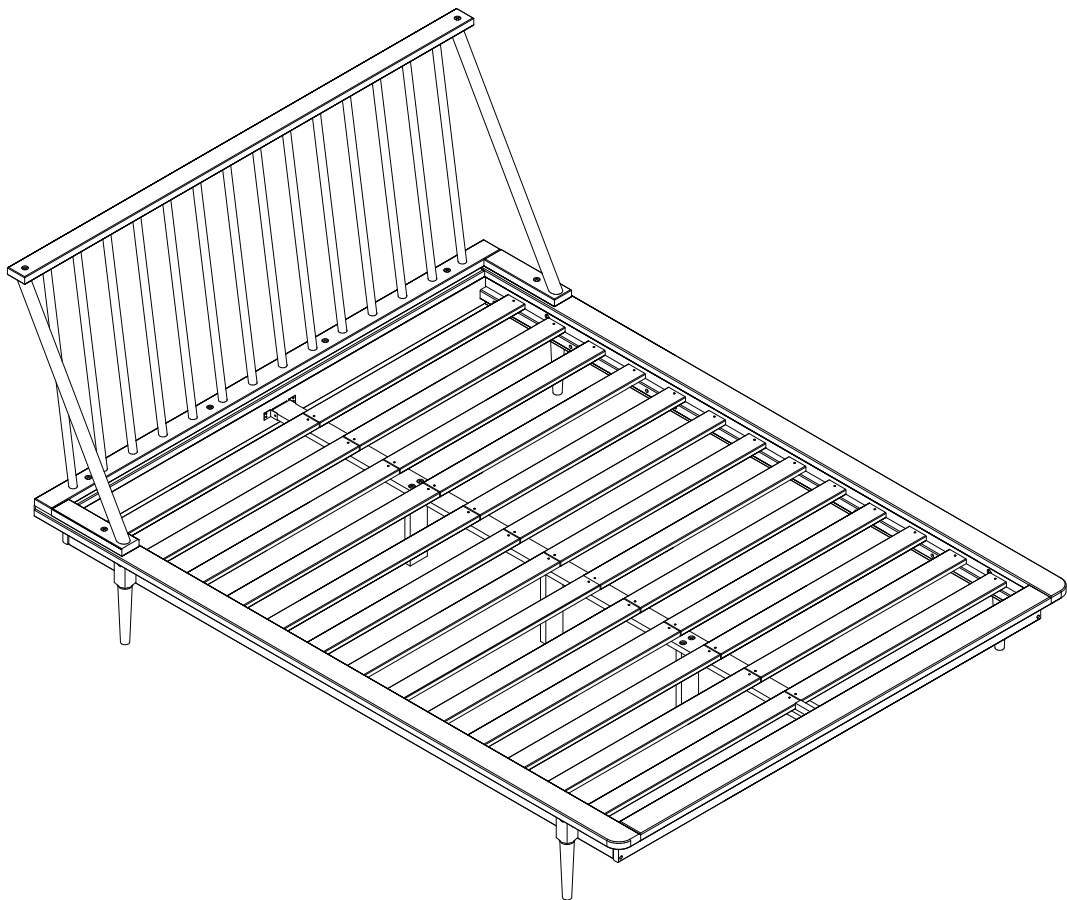

**Pour usage résidentiel seulement**

Visite notre site Web pour obtenir les instructions les plus récentes, des conseils d'assemblage, signaler des dommages ou commander des pièces. [www.walkerediton.com](http://www.walkerediton.com)

**Sólo para uso residencial**

Visite nuestro sitio web para consultar las últimas instrucciones, consejos de montaje, notificar daños o solicitar piezas. [www.walkerediton.com](http://www.walkerediton.com)



# Il est temps de commencer / Hora de empezar

Prépare un lieu de travail propre et souple pour éviter tout dommage lors de l'assemblage. Tu peux utiliser la boîte et les protections internes comme base. Vérifie également que tu disposes de toutes les pièces et parties avant de te lancer dans l'assemblage.

Prepare un lugar de trabajo limpio y blando para evitar daños durante el montaje. Puede utilizar la caja y las protecciones internas como base. Comprueba también que tiene todas las piezas y partes antes de sumergirse en el montaje.

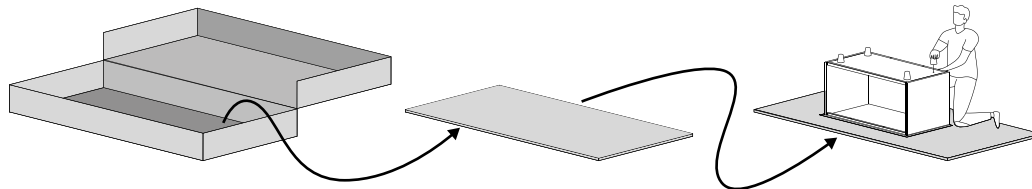

**Temps de montage  
estimé**  
**Tiempo estimado de  
montaje**

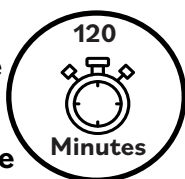

2 Personnes  
2 Personas

## Personnes recommandées pour le montage

Fais-en un effort d'équipe !  
Appelle un ami pour un  
assemblage plus rapide et plus  
facile.

## Personas recomendadas para el montaje

¡Hágalo en equipo!  
Llame a un amigo para que el  
montaje sea más rápido y sencillo.

### Outils nécessaires

Munis-toi d'un tournevis cruciforme pour réaliser cet assemblage. Tu auras également besoin d'un marteau pour t'aider.

### Herramientas requeridas

Tome un destornillador Phillips pour conquister este conjunto. También necesitaremos un martillo para ayudar.

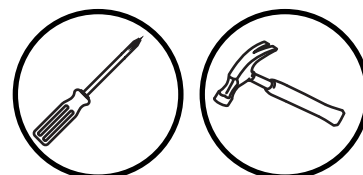

### Utilise les outils électriques avec précaution

Ce meuble est réalisé en Bois Massif et Bois Composite, des matériaux souples. Si tu choisis d'utiliser des outils électriques, règle-les sur le mode le plus lent. Fais attention à toi ! Les outils électriques peuvent provoquer des fissures ou endommager les meubles, mais aussi les autres composants s'ils sont mal utilisés. Les dommages causés par un outil électrique ne sont pas couverts par la garantie Walker Edison.

### Utilice las herramientas eléctricas con cuidado.

Este mueble está fabricado con madera maciza y madera compuesta, materiales blandos. Si decide utilizar herramientas eléctricas, ajústelas al ajuste más lento. Tenga cuidado. Las herramientas eléctricas pueden causar grietas o daños en el mueble, pero también en los herrajes si se utilizan mal. Los daños causados por una herramienta eléctrica no están cubiertos por la garantía de Walker Edison.

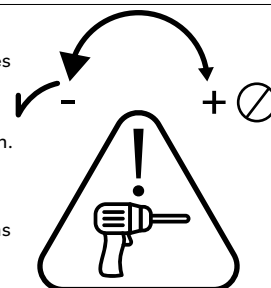

Scannez pour obtenir des conseils d'assemblage et de l'aide !  
¡Escanee para obtener consejos de montaje y ayuda!

# WE Liste de pièces / Lista de piezas





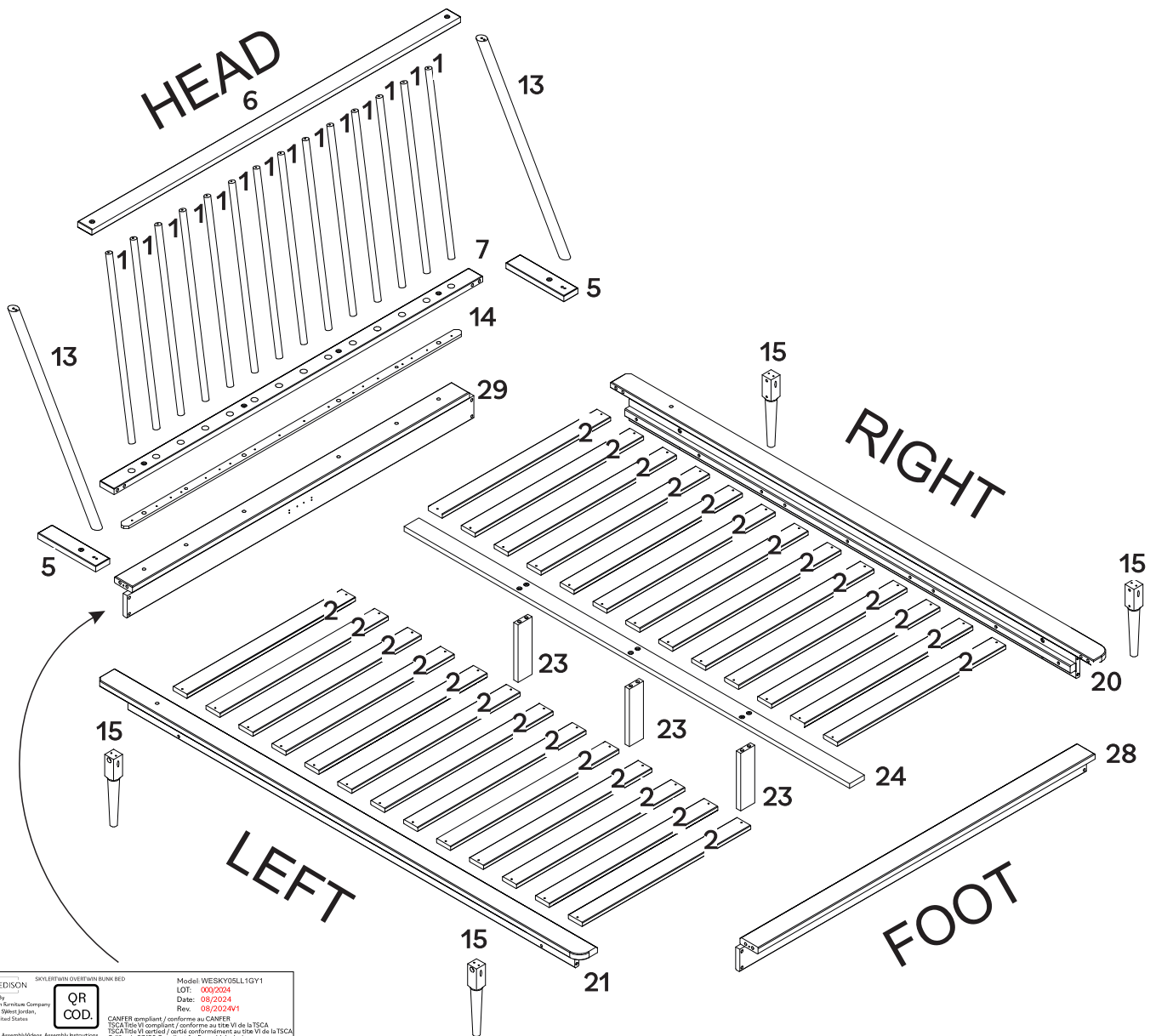

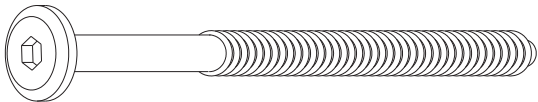

Nombre de pièces Número de pieza	Description Descripción	Quantité Cantidad
1	Spindle Spindle	14
2	Lattes Listones	26
5	Support Soporte	2
6	Barre supérieur Travesaño superior	1
7	Barre inférieur Travesaño inferior	1
13	Barre du support Barra de soporte	2
14	Support de Spindle Soporte de Spindle	1

Nombre de pièces Número de pieza	Description Descripción	Quantité Cantidad
15	Pieds Pies	4
20	Barre droit Travesaño derecho	1
21	Barre gauche Travesaño izquierdo	1
23	Pied Centrale Pie Central	3
24	Traverse centrale Soporte Central	1
28	Barre avant Travesaño delantero	1
29	Barre arrière Travesaño trasero	1

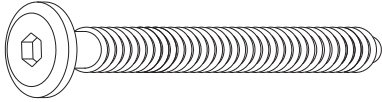
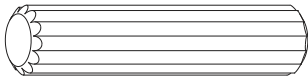

WALKER EDISON SKYLINE OVERVIEW BUNK BED Model: WESKY05LL1GY1  
 Distributed By: LOT: 000/2024  
 Walker Edison Furniture Company Date: 08/2024  
 1553W 9050 Street, Jordan Rev: 08/2024V1  
 UT 84088 United States  
 QR COD  
 CANFERE emplatat / conforme au CANFERE  
 TSCA Toxicity Information / conforme au TSCA  
 TSCA Title VI actual / conforme al TSCA  
 California 95120 Regulated for Formaldehyde /  
 Conforms to the new California 95120 prior to formaldehyde.

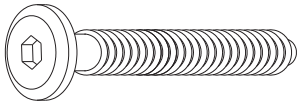
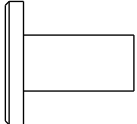
## Liste de composants / Lista de hardware

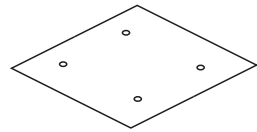
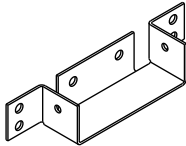
Partie Parte	Taille Tamaño	Nom Nombre	Quantité Cantidad
A 	7,0x70mm	Boulon Perno	14
B 	3,5x30mm	Vis Tornillo	94
D 	7,0x50mm	Boulon Perno	8
E 	10x40mm	Cheville Espiga	14
F 	6x30mm	Cheville Espiga	4
J 		Clé hexagonale Llave hexagonal	2
L 	83mm	Espaceur Espaciador	2
M 	1/4x40mm	Boulon Perno	10
N 	1/4mm	Connexion Conexión	10
P 	4,0x16mm	Vis Tornillo	28
Q 		Plaque Métallique Placa Metálica	2
R 		Soutien Apoyo	2

*Les quantités de composants indiquées ci-dessus sont nécessaires pour un assemblage correct.  
Des pièces supplémentaires peuvent être incluses.*

*Las cantidades de tornillería indicadas anteriormente son necesarias para un montaje correcto.  
Se pueden incluir piezas de ferretería adicionales.*

# Étape / Paso 1

(FR) Commençons! Insère las Chevilles (E) dans le Support (5), Barre Avant (28), Barre Arrière (29). Aussi insère las Chevilles (F) dans le Barre du Support (13).

(ES) ¡Manos a la obra! Inserta las Espigas (E) en el Soporte (5), Travesaño Delantero (28), Travesaño Trasero (29). También inserta las Espigas (E) en el Travesaño de Soporte (13).

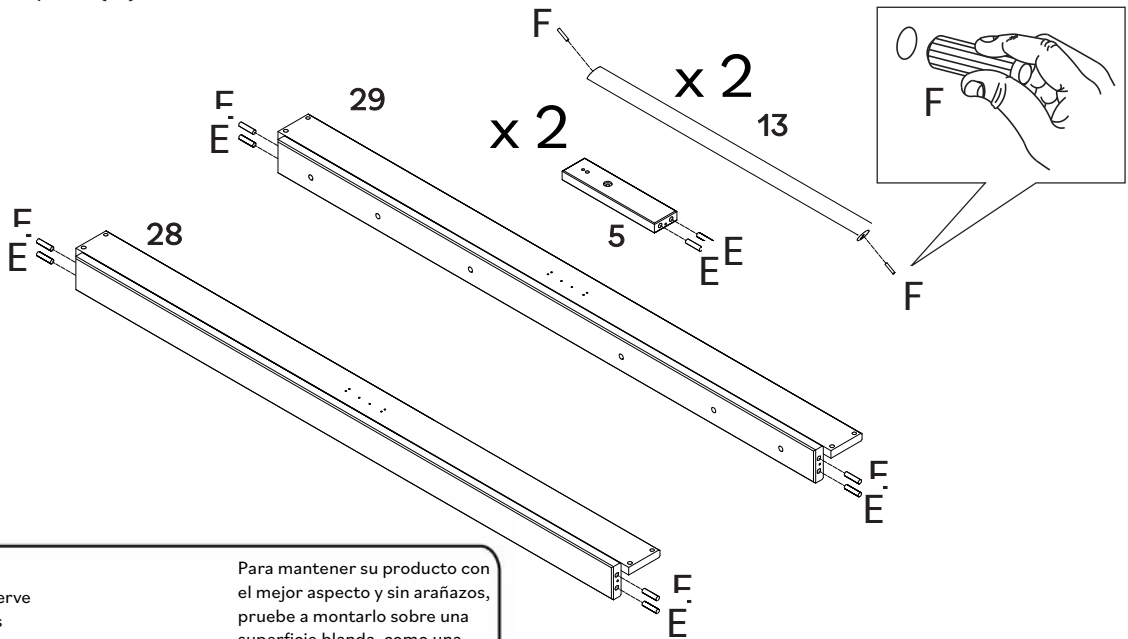

Tip

Pour que ton produit conserve son meilleur aspect et sans rayures, essaie de le monter sur une surface souple telle qu'un tapis ou une couverture. Cela permet d'éviter les rayures accidentelles et de garder tes meubles en bon état!



Para mantener su producto con el mejor aspecto y sin arañazos, pruebe a montarlo sobre una superficie blanda, como una alfombra o una manta. Así evitará arañazos accidentales y mantendrá sus muebles en perfecto estado.

# Étape / Paso 2

(FR) Fixez le Soutien (R) au Barre Avant (28) et au Barre Arrière (29) à l'aide de la Vis (P) et d'un tournevis Phillips.

(ES) Conecte el Apoyo (R) al Travesaño Delantero (28) y Travesaño Trasero (29) usando el Tornillo (P) y un destornillador Phillips.

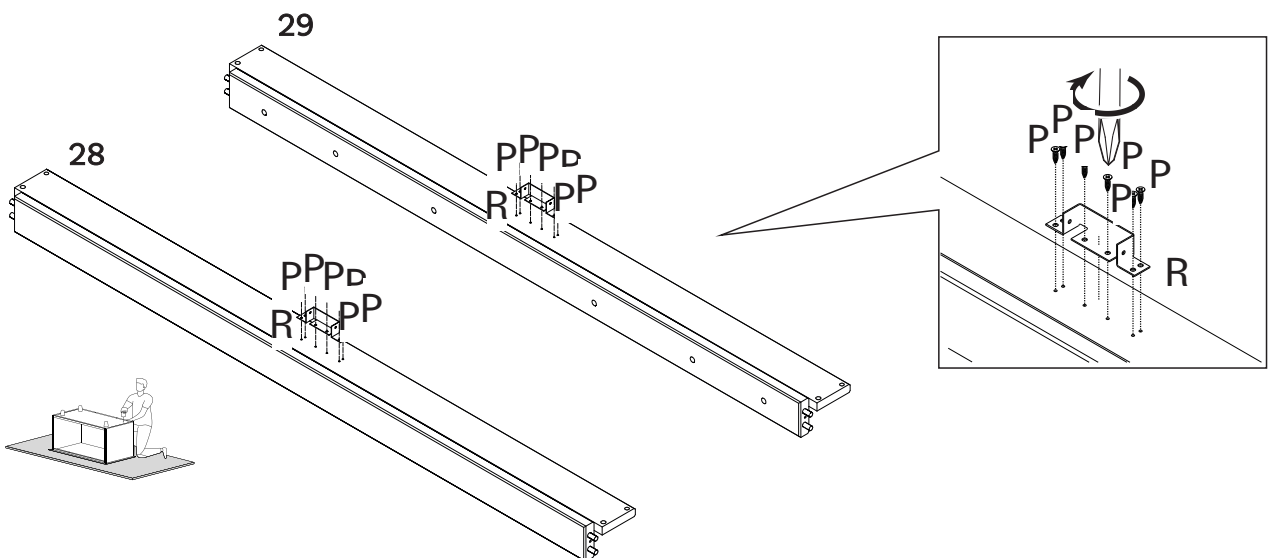

# Étape / Paso 3

(FR)

Fixez le Support de Pied Central (23) à la Traverse Centrale (24) à l'aide du Boulon (A) et de la clé Allen (J).

(ES)

Asegure el Soporte del Pie Central (23) al Soporte Central (24) usando el Perno (A) y la llave Allen (J).

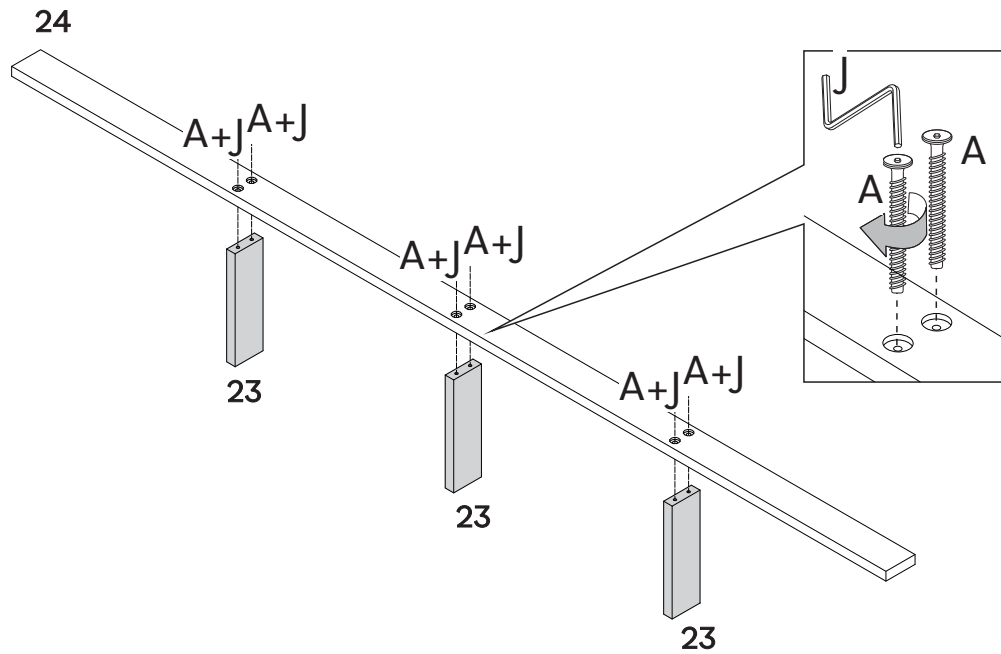

# Étape / Paso 4

(FR)

Joignez le Barre Droit (20) et le Barre Gauche (21) au Barre Avant (28) et au Barre Arrière (29).

(ES)

Una el Travesaño Derecho (20) y el Travesaño Izquierdo (21) al Travesaño Delantero (28) y al Travesaño Trasero (29).

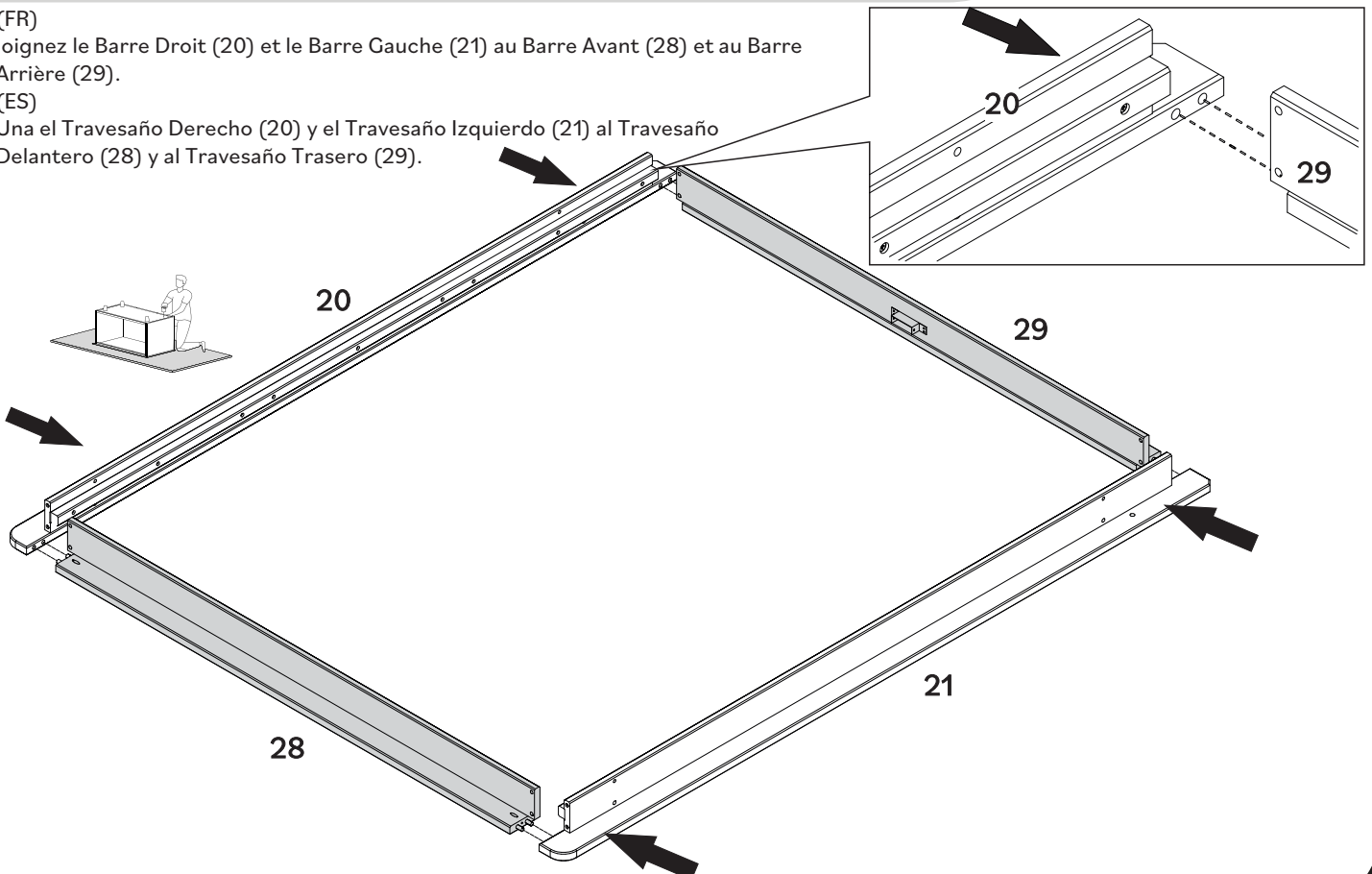



# Étape / Paso 5

(FR)

Sécurisez les pièces que vous venez de joindre à l'aide du Boulon (A) et de la clé Allen (J).

(ES)

Asegure las piezas que acaba de unir usando el Perno (A) y la llave Allen (J).

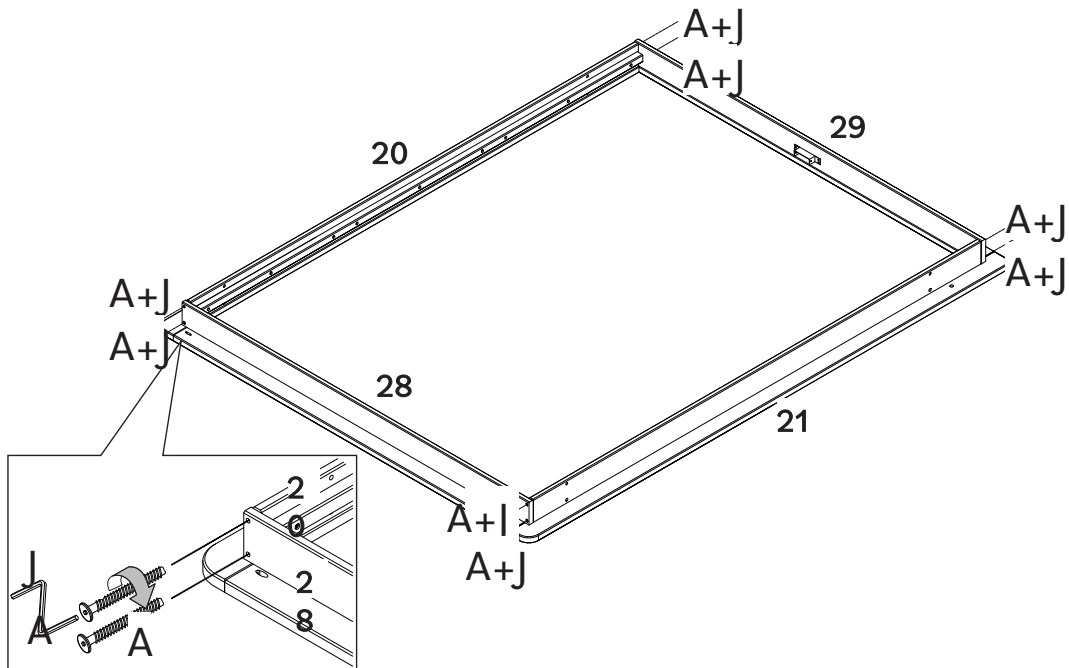

# Étape / Paso 6

(FR)

Utilisez également la Vis (B) et un tournevis Phillips pour fixer le Barre Droit (20) et le Barre Gauche (21) au Barre Avant (28) et Barre Arrière (29).

(ES)

Utilice también el Tornillo (B) y un destornillador Phillips para fijar el Travesaño Derecho (20) y el Travesaño Izquierdo (21) al Travesaño Frontal (28) y al Travesaño Trasero (29).

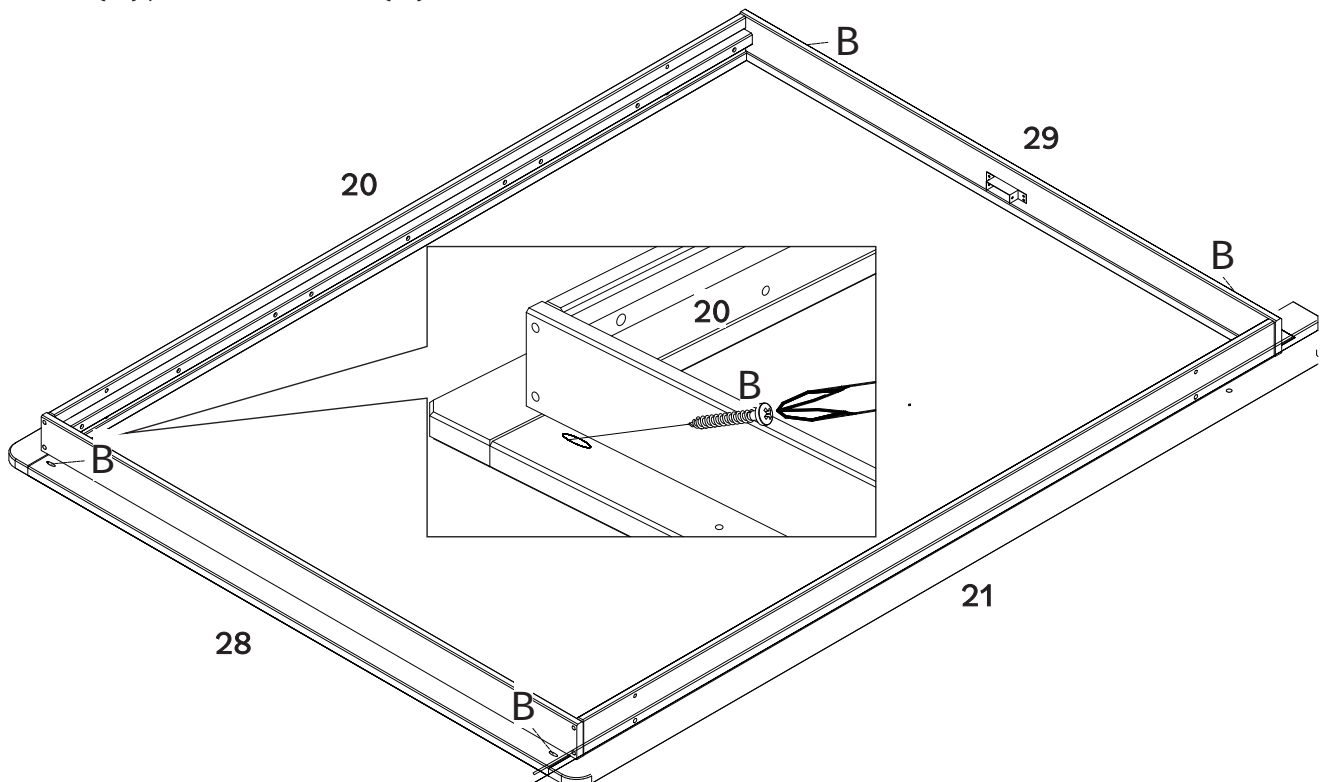

# Étape / Paso 7

(FR)

Assemblez les Pieds (15) au Barre Droit (20) et au Barre Gauche (21) à l'aide du Boulon (M), Boulon d'Union (N) et de la clé Allen (J). Le Boulon d'Union doit être à l'intérieur des Barres Latérales (20,21) et le Boulon (M) à l'extérieur des Pieds (15). Utilisez également le Boulon (D) et la clé Allen (J) pour fixer les Pieds (15).

(ES)

Ensamble los Pies (15) al Travesaño Derecho (20) y al Travesaño Izquierdo (21) usando el Perno (M), el Perno de unión (N) y la llave Allen (J). El Perno de Unión debe estar en el interior de los travesaños Laterales (20,21) y el Perno (M) en el exterior de los Pies (15). Utilice también el Perno (D) y la llave Allen (J) para asegurar los Pies (15).

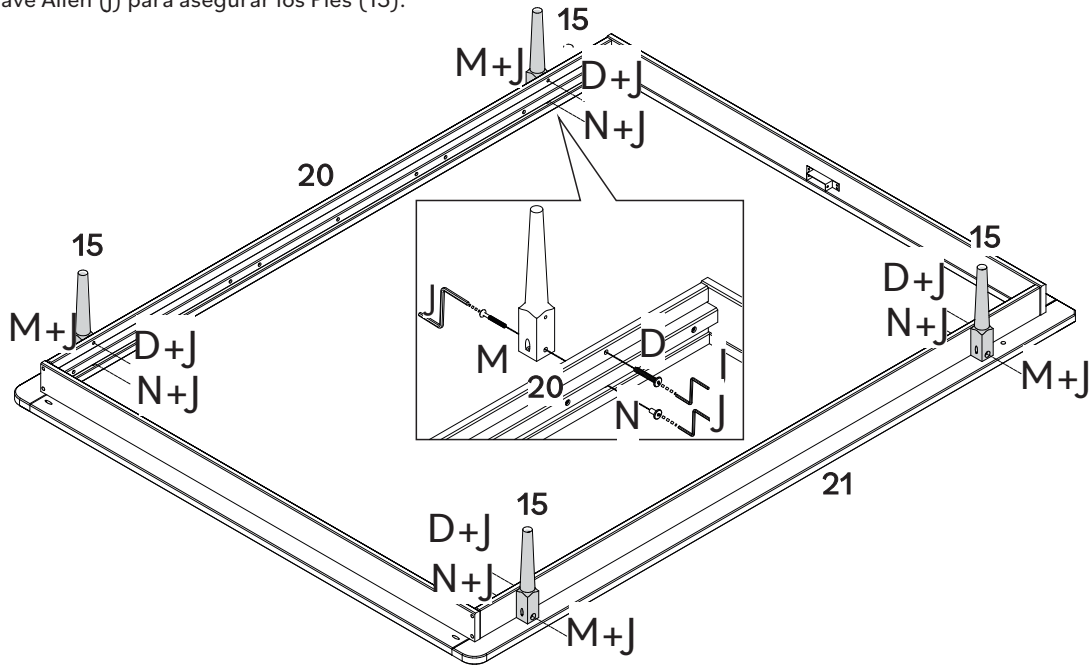

# Étape / Paso 8

(FR)

Terminez de fixer les Pieds (15) à l'aide de la Vis (B) et d'un tournevis Phillips.

(ES)

Termine de fijar los Pies (15) usando el Tornillo (B) y un destornillador Phillips.

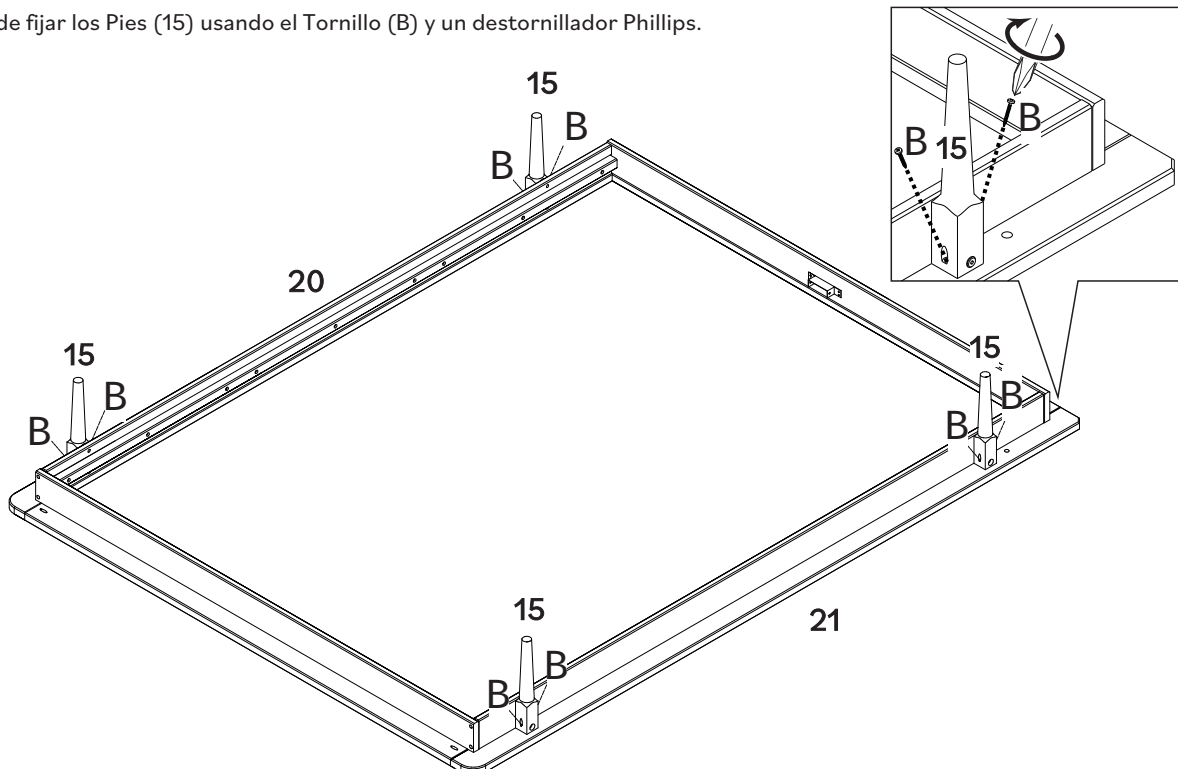

# Étape / Paso 9

(FR) Fixez le Plaque Métallique (Q) sur la division entre les Barres Latérales (20, 21) et le Barre Avant (28) à l'aide de la Vis (P) et d'un tournevis Phillips.

(ES) Conecte la Placa Metálica (Q) en la división entre los Travesaños Laterales (20,21) y el Travesaño Frontal (28) usando un Tornillo (P) y un destornillador Phillips.

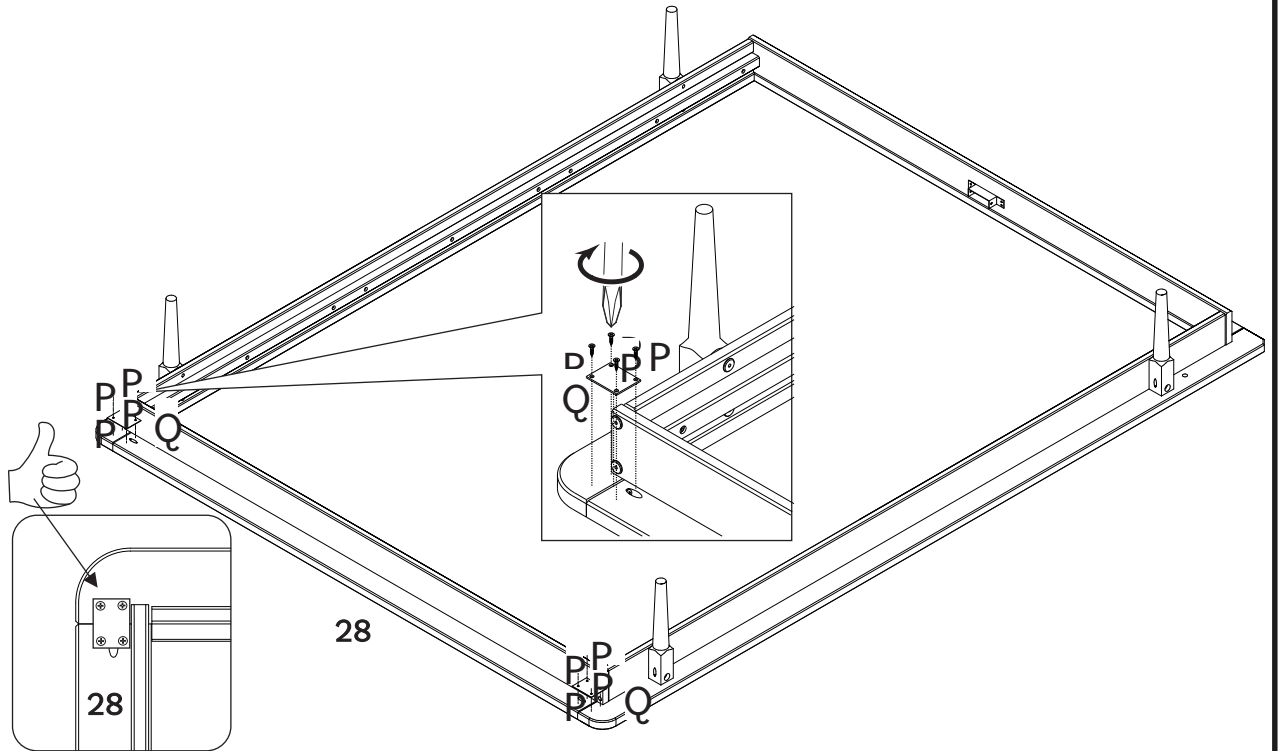

# Étape / Paso 10

(FR) Fixez la Traverse Centrale (24) au Soutien (R) à l'aide de la Vis (P) et d'un tournevis Phillips.

(ES) Asegure el Travesaño Central (24) al Apoyo (R) usando el Tornillo (P) y un destornillador Phillips.

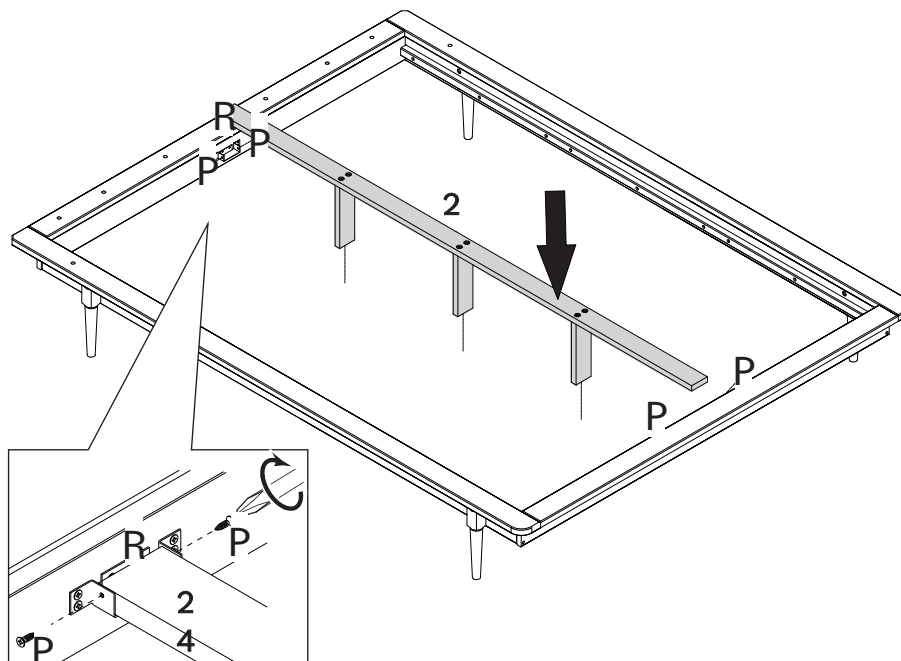

# Étape / Paso 11

(FR) Placez les Latte de sommier (2) sur les Barres et la Traverse Centrale. Utilisez l'Espaceur (L) pour régler la distance entre les lattes, puis fixez-la à l'aide de la Vis (B) et d'un tournevis Phillips.

(ES) Coloque los Listones (2) sobre los Travesaños Laterales (20, 21) y el Travesaño Central (24). Utilice el espaciador (L) para establecer la distancia entre los listones, luego asegúrelos con el Tornillo (B) y un destornillador Phillips.

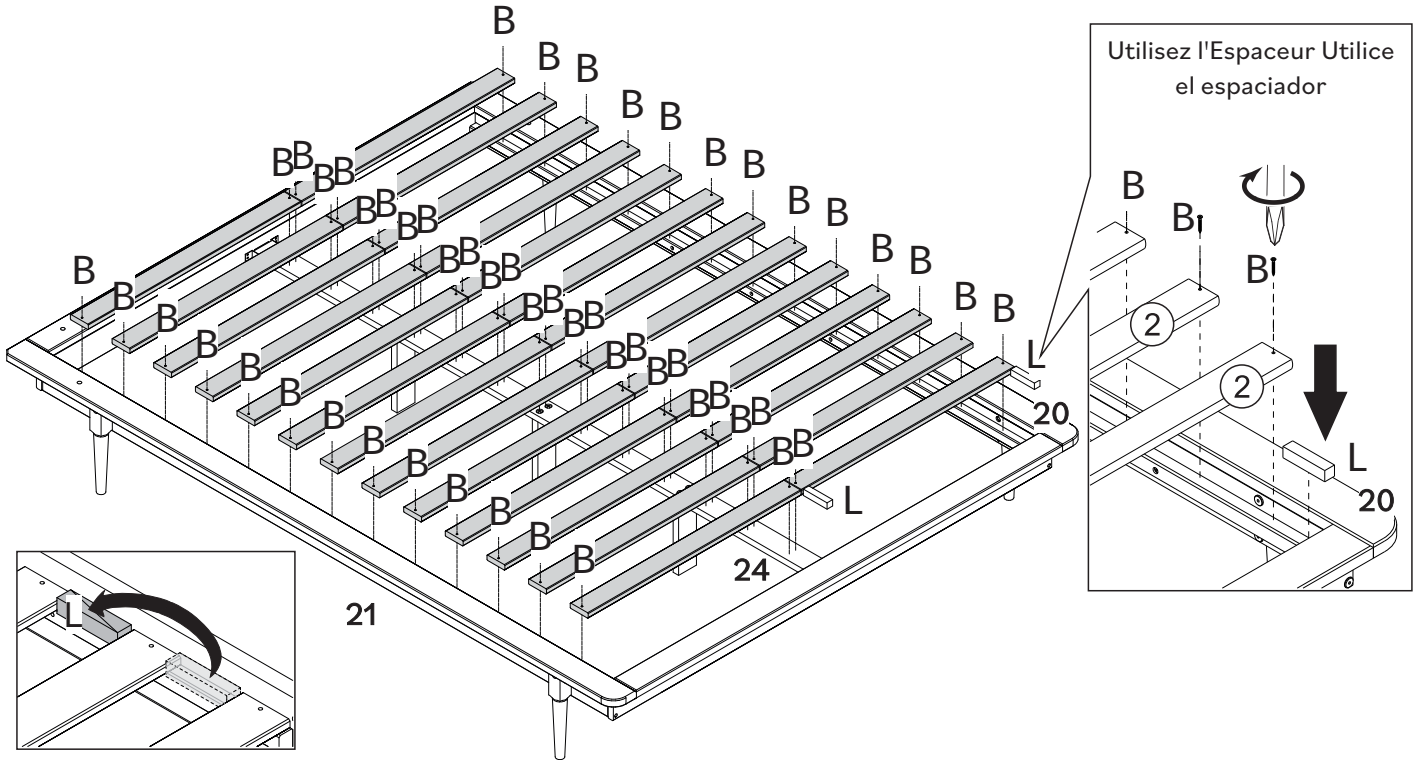

# Étape / Paso 12

(FR) Commençons par assembler la tête de lit! Connectez le Support (5) au Barre Inférieure (7). Faites attention au côté où doit se trouver le trou de poche. Fixez-le à l'aide de la Vis (B) et d'un tournevis Phillips.

(ES) ¡Empecemos a montar el cabecero! Conecte el Soporte (5) al Travesaño Inferior (7). Preste atención al lado donde debe estar el agujero de bolsillo. Fíjelo con el Tornillo (B) y un destornillador Phillips.

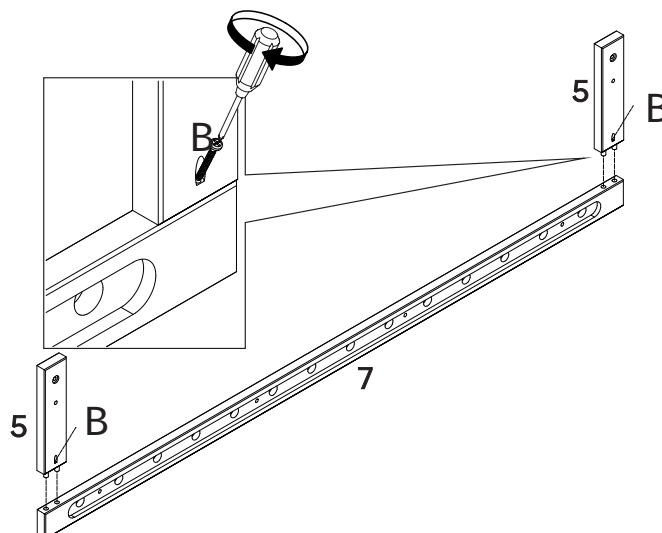

# Étape / Paso 13

(FR)

Joignez la Barre de Support (13) au Barre Supérieur (6) à l'aide du Boulon (D) et de la clé Allen (J).

(ES)

Una la Barra de Soporte (13) al Travesaño Superior (6) usando el Perno (D) y la llave Allen (J).

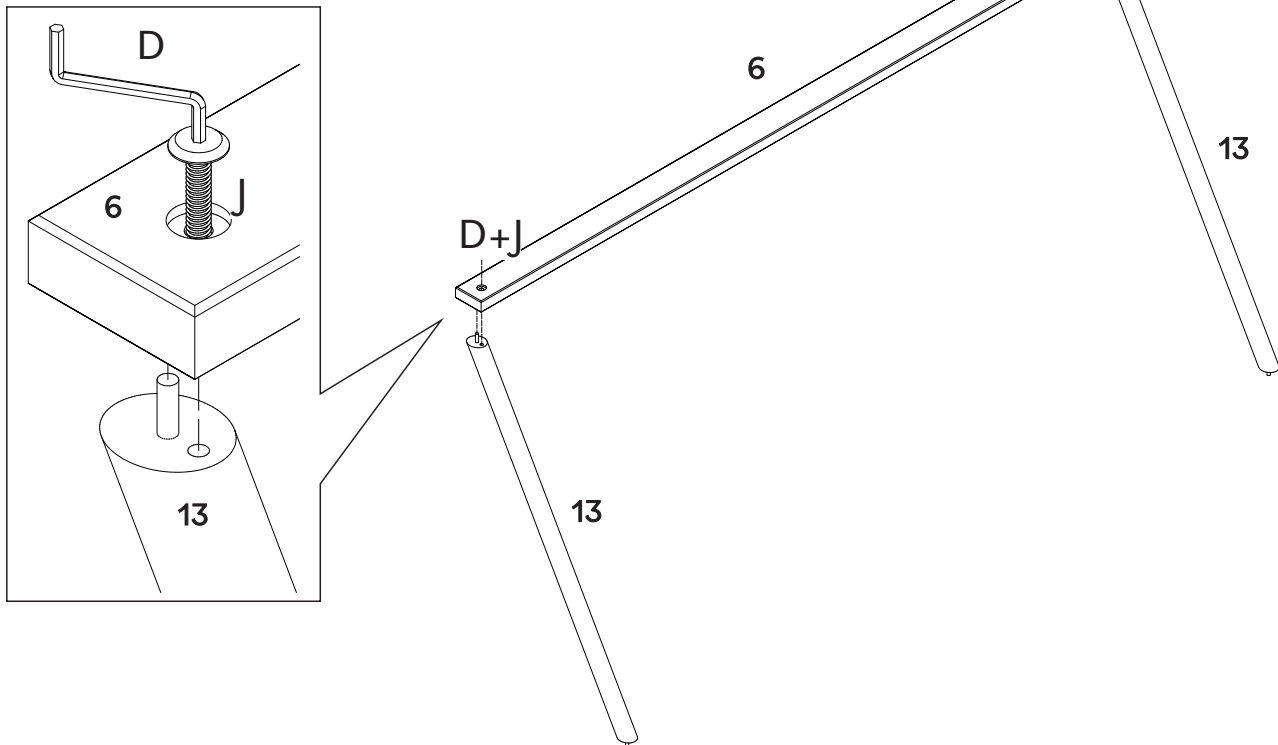

# Étape / Paso 14

(FR)

Installez la Barre de Support (13) sur le Support (5) et fixez-la à l'aide de la Vis (D) et de la clé Allen (J).

(ES)

Coloque la Barra de Soporte (13) en el Soporte (5) y asegúrela con el Tornillo (D) y la llave Allen (J).

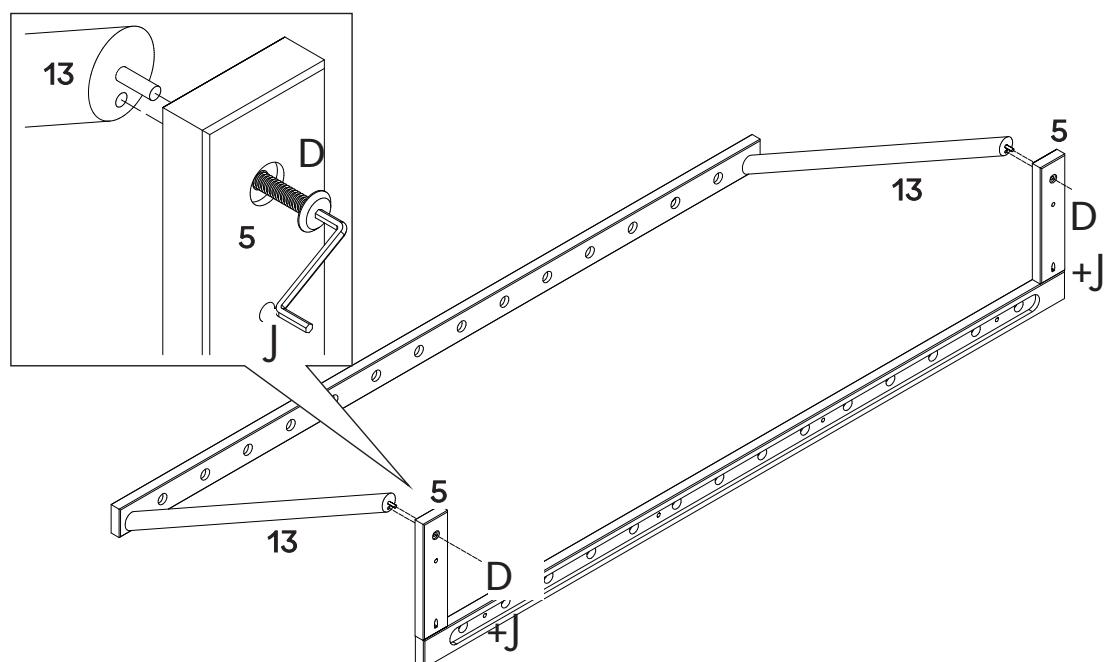

# Étape / Paso 15

(FR) Insérez les Spindles (1) dans les trous du Barre Inférieure (7) en les plaçant dans le Barre Supérieur (6) et en les fixant avec la Vis (B) et un tournevis Phillips.

(ES) Inserte los Spindles (1) en los agujeros del Travesaño Inferior (7) que se ajustan al Travesaño Superior (6) y asegúrelos con un Tornillo (B) y un destornillador Phillips.

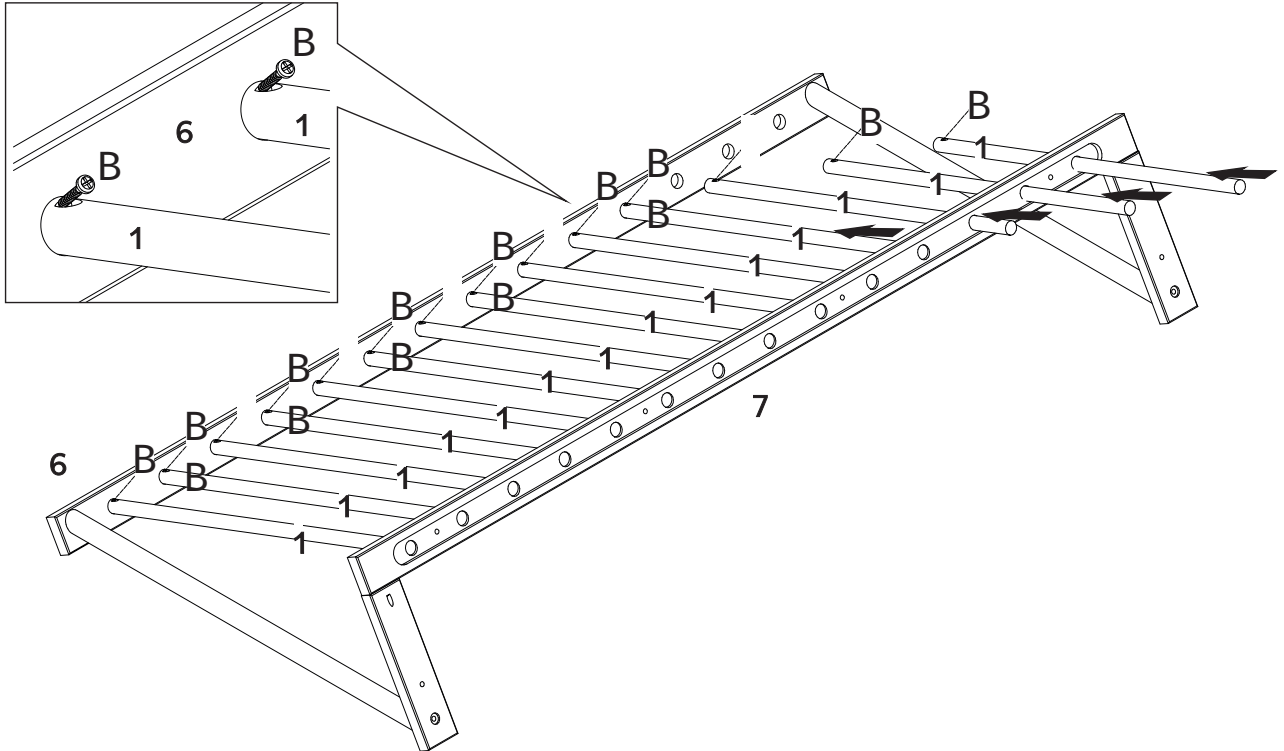

# Étape / Paso 16

(FR) Insérez le Support de Spindle (14) dans le Barre Inférieure (7) et fixez-le avec la Vis (P) et un tournevis Phillips.

(ES) Inserte el Soporte de Spindle (14) en el Travesaño Inferior (7) y fíjelo con un Tornillo (P) y un destornillador Phillips.

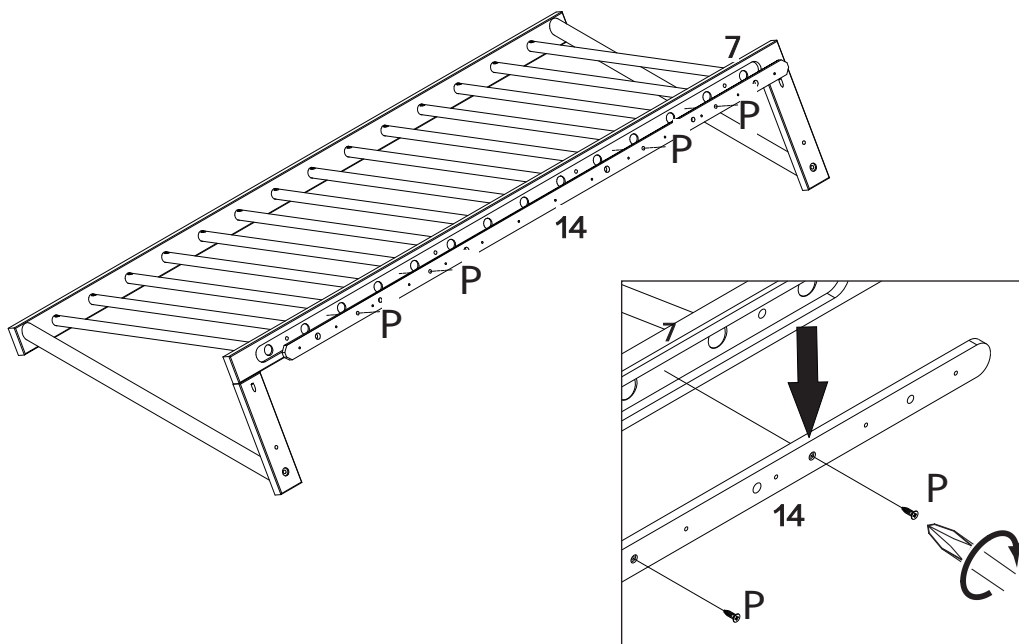

# Étape / Paso 17

(FR)

Utilisez la Vis (B) pour fixer les Spindles (1) au Support de Spindle (14).

(ES)

Utilice el Tornillo (B) para fijar los Spindles (1) al Soporte de Spindle (14).

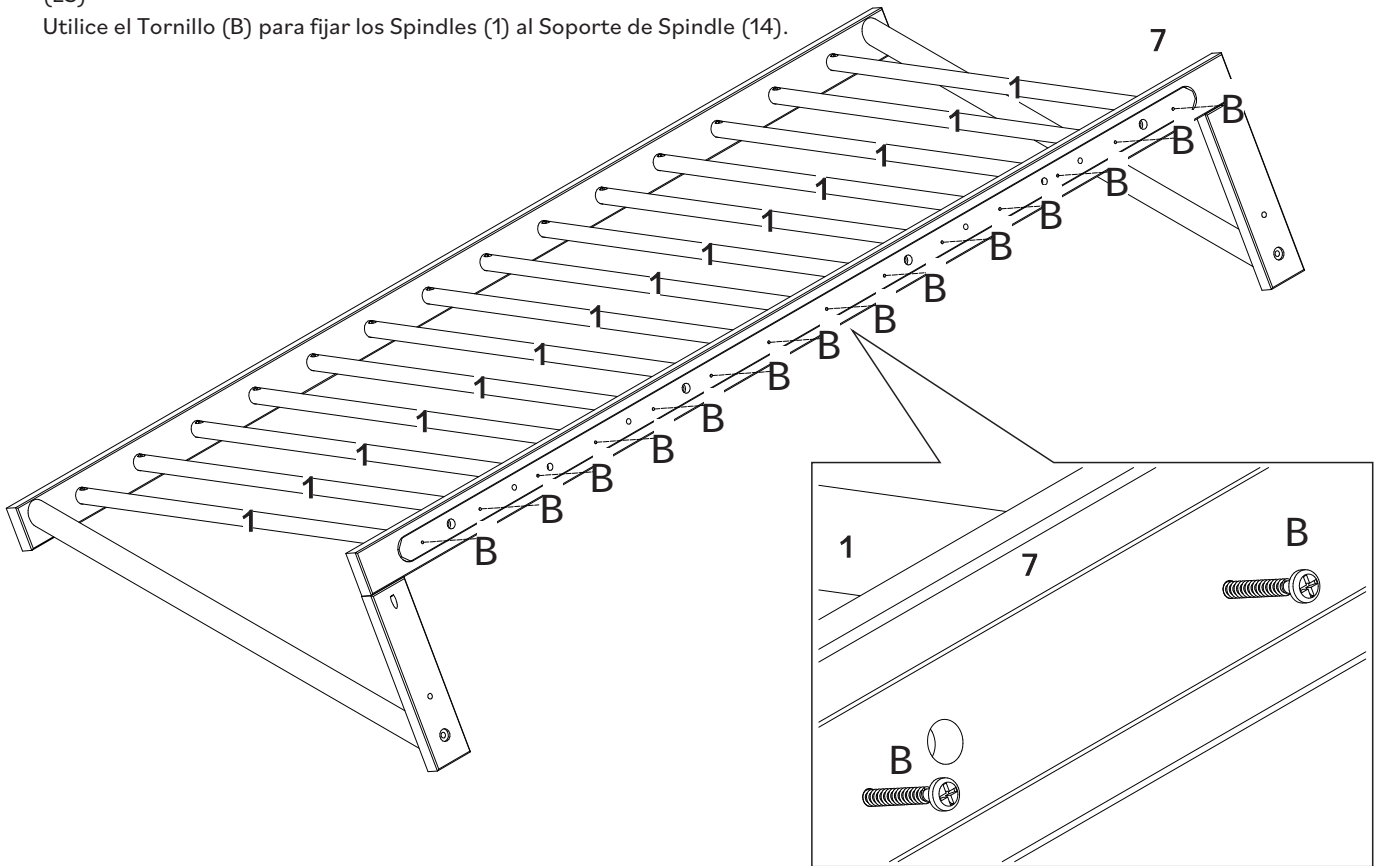

# Étape / Paso 18

(FR)

Insère les Chevilles (E) dans le Support de Spindle (14)

(ES)

Inserte las Espigas (E) en el Soporte de Spindle (14).

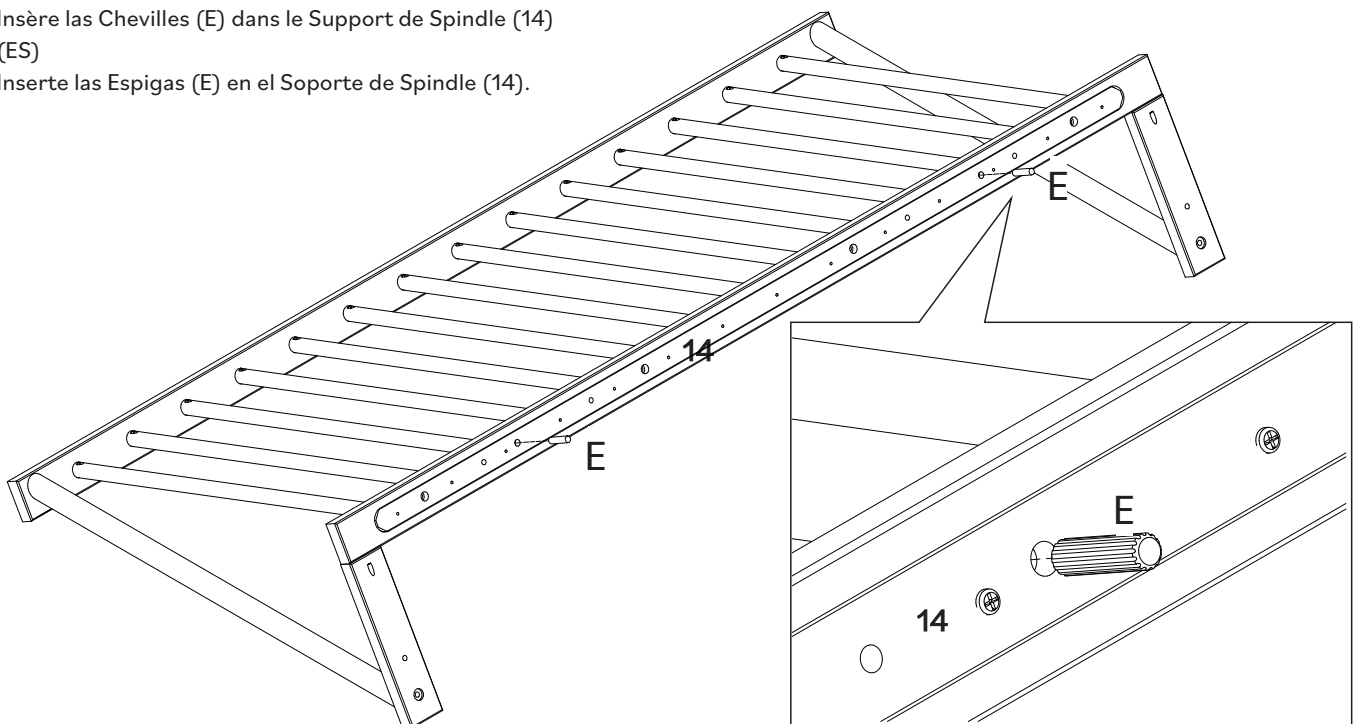

# Étape / Paso 19

(FR)

Insère les Chevilles (E) comme guide pour assembler la tête de lit et le lit assemblés. Pressez fermement les pièces ensemble

(ES)

Utilice las Espigas (E) como guía para unir la cabecera y la cama ensambladas. Presione las piezas juntas firmemente.

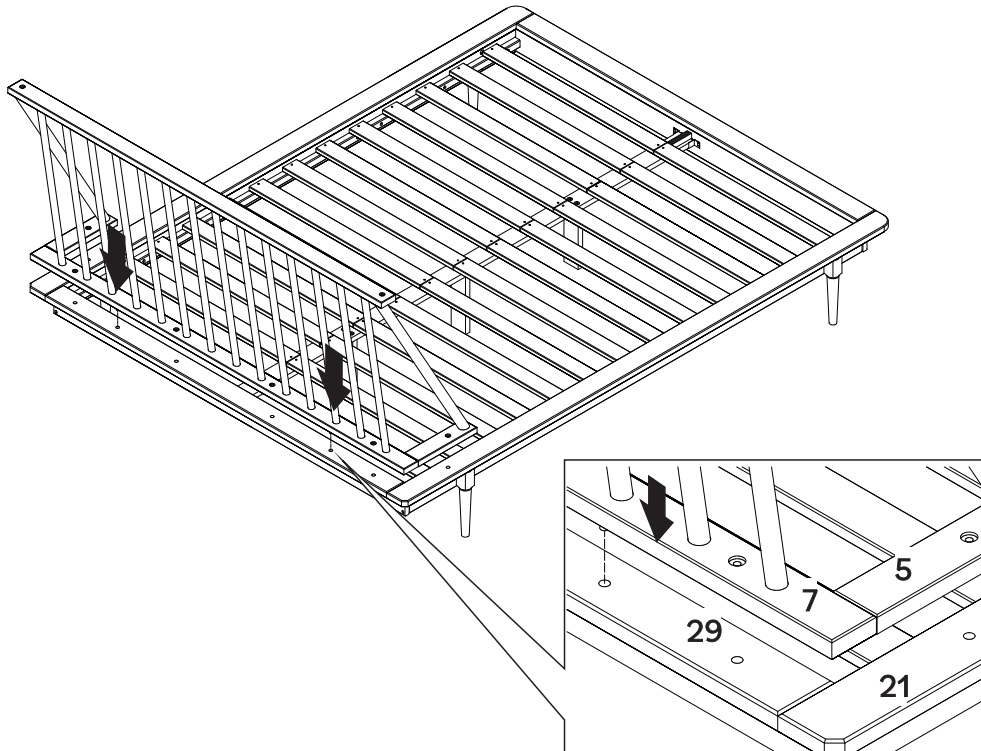

# Étape / Paso 20

(FR)

Fixez les deux pièces ensemble à l'aide du Boulon (M), de Boulon d'Union (N) (N) et de la clé Allen (J).

(ES)

Asegure ambas piezas juntas usando el Perno (M), el Perno de Unión (N) y la llave Allen (J).

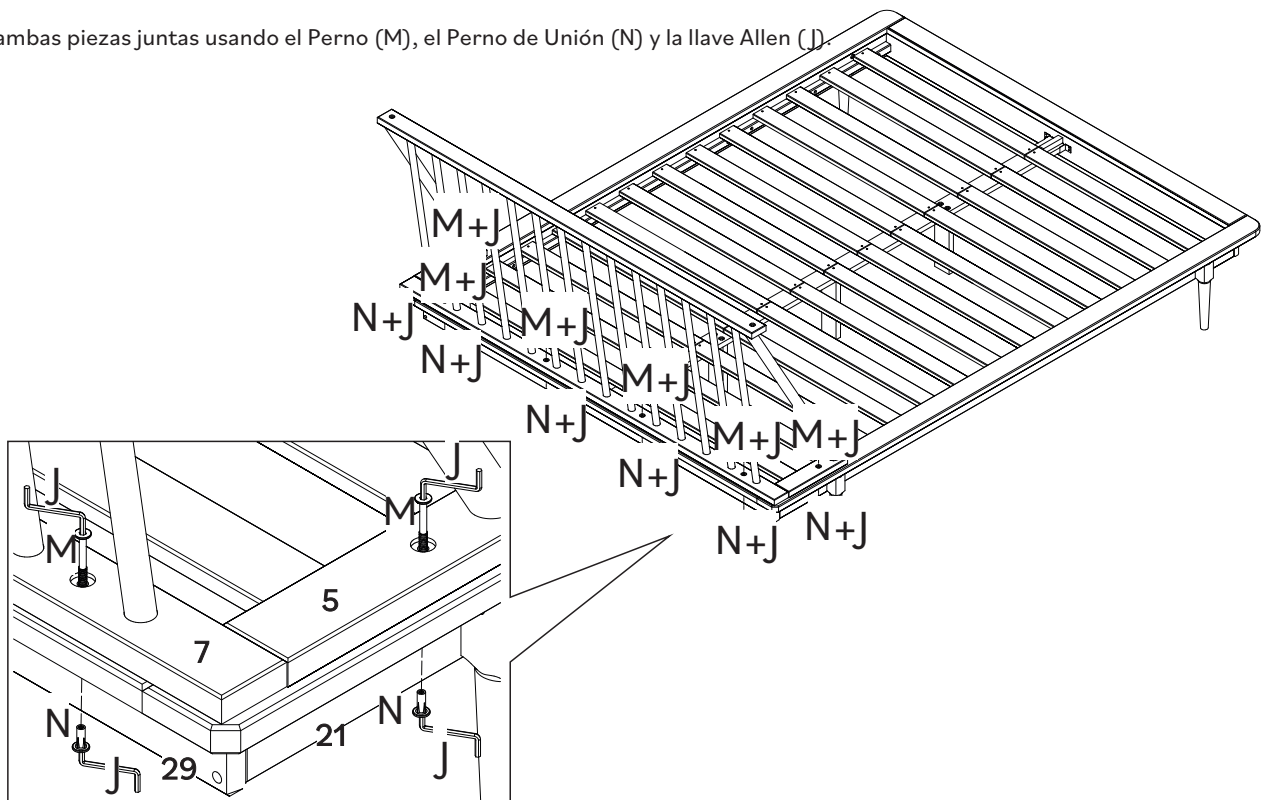



Tu as réussi ! Profite bien de ton nouveau lit Queen !  
¡Lo lograste! ¡Disfruta de tu nueva cama Queen!

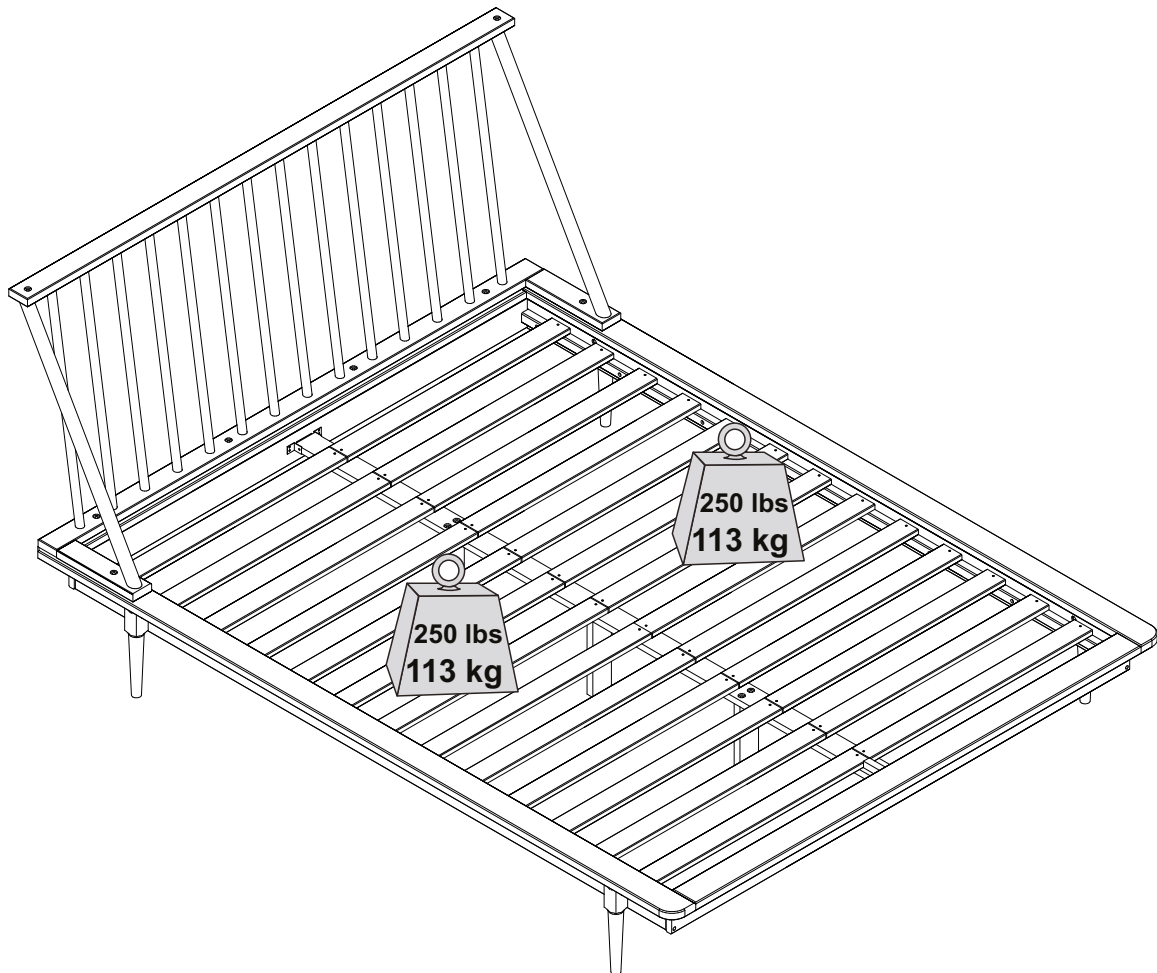

**Bravo pour ton nouveau meuble !**

Nous aimerions t'en entendre parler et le voir.

S'il te plait, laisse-nous un commentaire ou publie une photo sur

**#mywalkerredisonhome**

**¡Enhorabuena por sus nuevos muebles!**

Nos encantaría oírlo y verlo.

Por favor, déjenos un comentario o publique una foto con

**#mywalkerredisonhome**

## Assembler des meubles peut parfois être compliqué.

Notre équipe de service client, située dans l'Utah, est là pour obtenir des informations sur les produits, aider pour l'assemblage d'un produit ou pour tout autre problème de support client.

Appelle-nous **801-433-3008**

Envoie-nous les e-mails à [service@walkeredison.com](mailto:service@walkeredison.com)

Visite notre site accueil au client à

[walkeredison.com/pages/customer-service](http://walkeredison.com/pages/customer-service)

Nous sommes disponibles pour t'aider du Lundi au Jeudi de 8 am - 5 pm, Vendredi de 8 am - 3 pm MST.

Pour plus de détails sur les vidéos d'assemblage,  
les instructions d'assemblage,  
les pièces de rechange et le service client.

NUMÉRISER ICI.



Pour le nettoyage, n'utilise jamais d'abrasifs, utilise un chiffon doux et de l'eau avec du savon neutre pour nettoyer les meubles.

## A veces, montar muebles puede resultar complicado.

Nuestro equipo de atención al cliente, ubicado en Utah, está a su disposición para informarle sobre los productos, ayudarlo a montarlos o resolver cualquier otro problema de atención al cliente.

Llámenos **801-433-3008**

Envíenos un correo electrónico a [service@walkeredison.com](mailto:service@walkeredison.com)

Visite nuestra página web de atención al cliente

[walkeredison.com/pages/customer-service](http://walkeredison.com/pages/customer-service)

Estamos a su disposición para ayudarlo de lunes a jueves de 8:00 a 17:00, viernes de 8:00 a 15:00 MST.

Para más detalles sobre videos de montaje, instrucciones  
de montaje, piezas de recambio y servicio de atención  
al cliente

ESCANEE AQUÍ.



Para la limpieza, nunca utilice productos abrasivos, utilice un paño suave y agua con jabón neutro para limpiar los muebles.