



Manufactured by:
 Backyard Discovery
 3305 Airport Drive, Pittsburg, KS 66762
 800-856-4445

Basepoint Business Centre: Rivermead Drive, Westlea, Swindon SN5 7EX Phone: 0800-118-2476 J.P. Coenstraat 7, The Bridge, The Hague, 2595 WP, Netherlands Phone: 08005678990

16x12 STRATFORD, ASHFORD, HAWTHORNE PERGOLA

Models #'s : 2105027B, 2105034B, 2105041B

The assembly manual must be retained since it contains important information



2105027B
 STRATFORD (BLACK)



2105034B
 ASHFORD (BROWN)



Electrical enclosure available only in North America



2105041 HAWTHORNE
 (WHITE)

Please visit www.backyarddiscovery.com
 For the most up to date assembly manual, to register your product, or to order replacement parts *Para obtener instrucciones en español, visite*
www.backyarddiscovery.com



EASY STEP-BY-STEP
 3D INTERACTIVE INSTRUCTIONS
 DOWNLOAD THE FREE APP



ONLY AVAILABLE IN NORTH AMERICA

Made in China

INS-2105027B, 2105034B, 2105041B-A-16X12 TRADITIONAL METAL PERGOLA-ENG 1-15-24

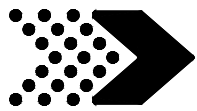

It is critically important that you start with square and level footings, concrete pad or deck to attach your structure

- Pay close attention to the items needed for each step. Make sure you are using the correct hardware for each step. Using incorrect hardware may result in improper assembly
- Remember to double check for underground utilities and overhead electrical lines

Post mounts are provided with your structure which allows you to permanently install your structure to a pre-existing or new wood or concrete surface.

- The hardware to attach the post mounts to the structure is included.
- The hardware to mount the structure permanently to a concrete surface is NOT included.
- The hardware to mount the structure permanently to a wood deck is NOT included and will need to be purchased separately. **You must ensure there is ample structural support under the deck before permanently attaching.**

Metal Roof Assembly

Remove plastic covering from metal roof panels before installing each piece. Place roofing materials on a nonabrasive, flat surface before and after assembly as it could bend, dent or scratch

Overall Dimensions

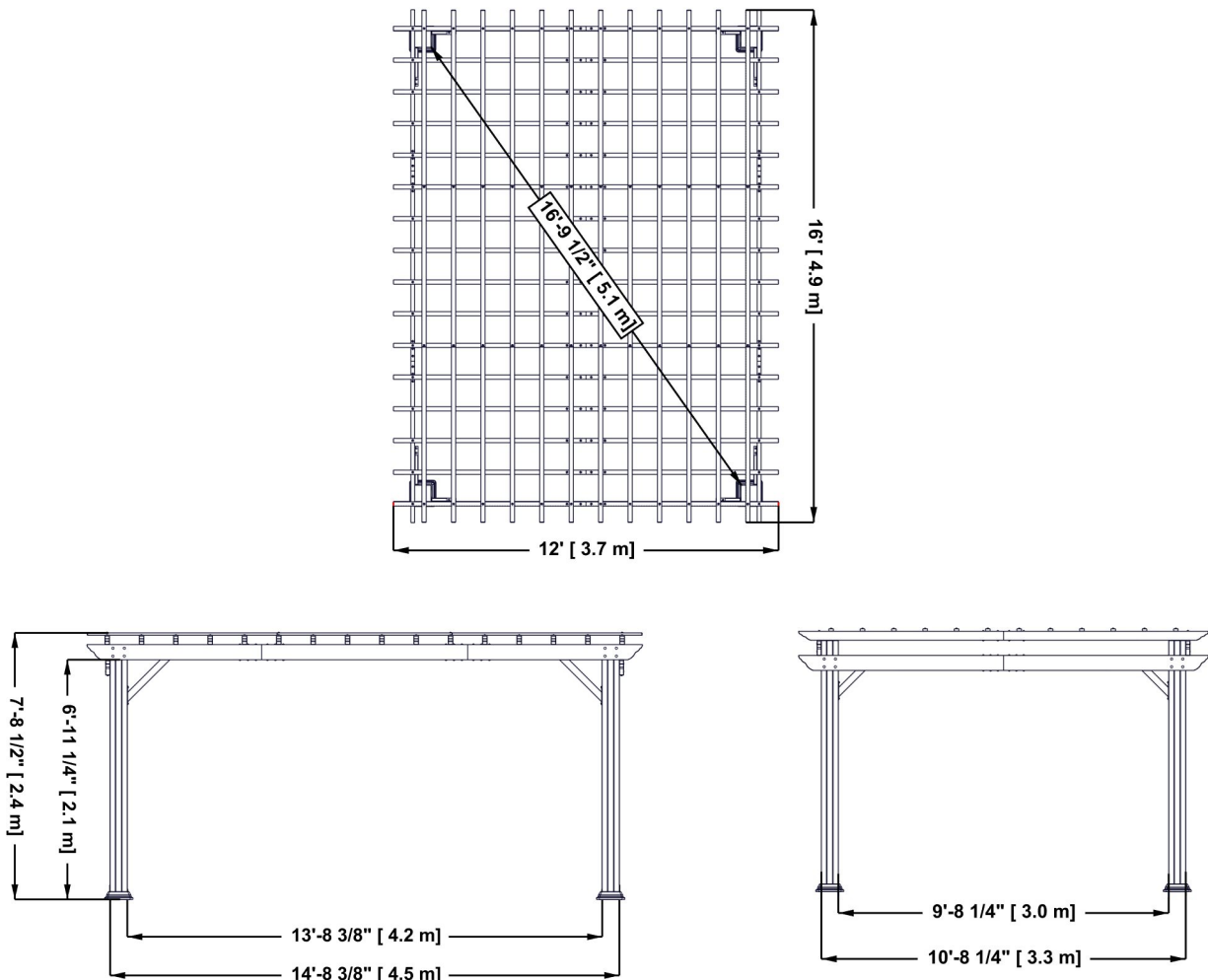

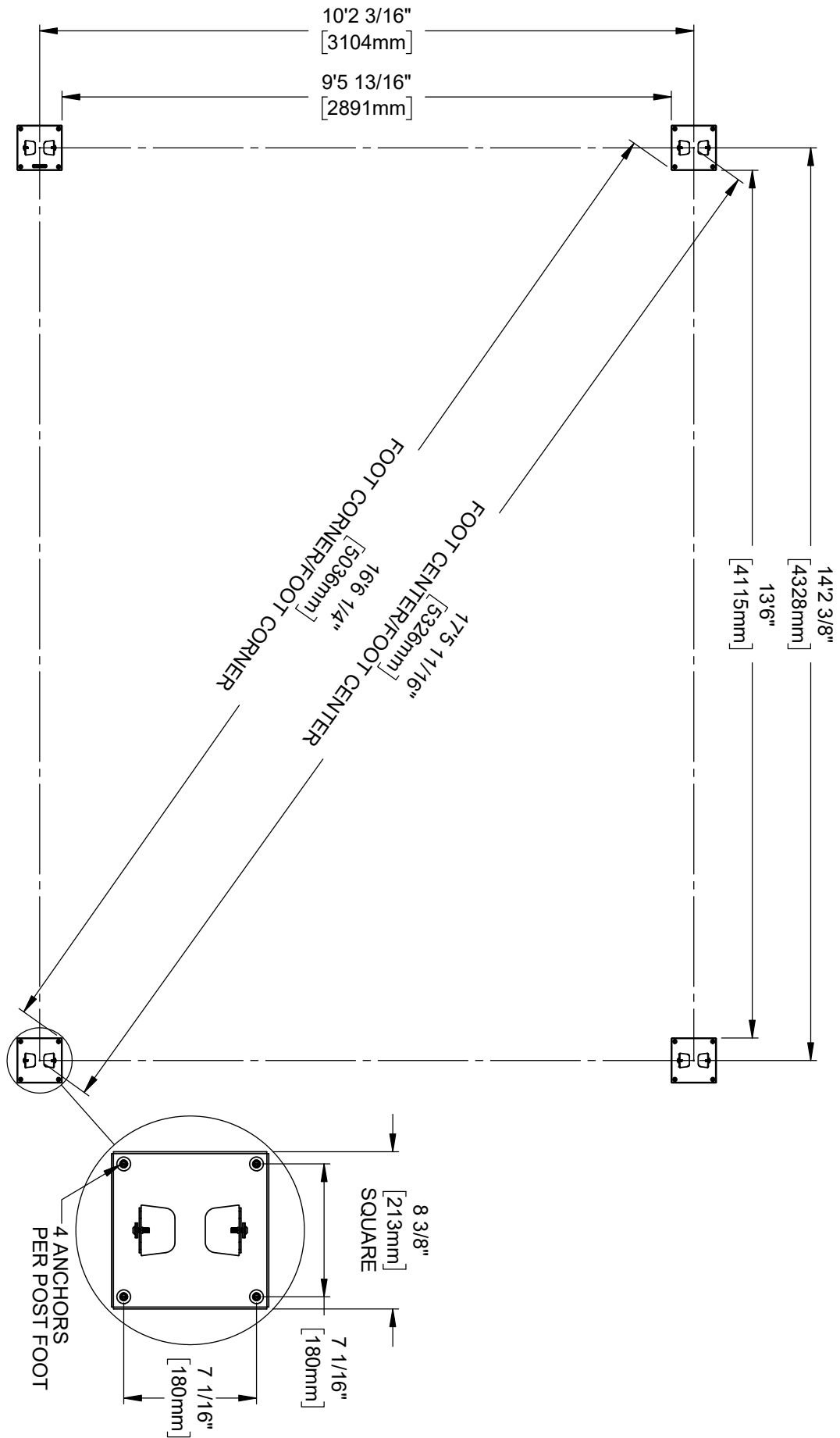
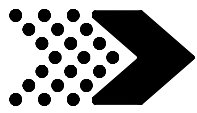

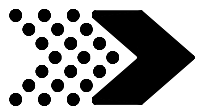

Metal Components (Not to Scale)

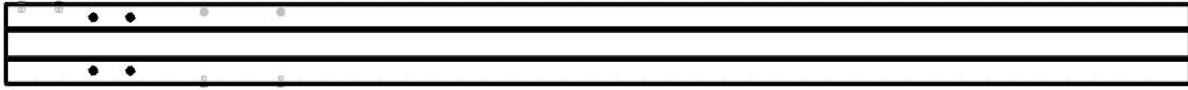

A1 POST - A4M01565
(2) 6"x6"x88" (152x152x2235)

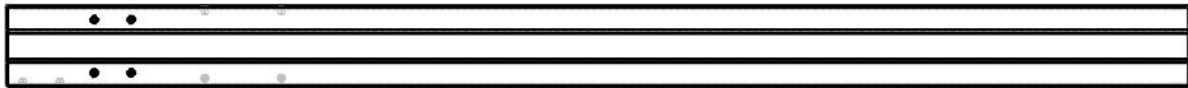

A2 POST - A4M01566
(2) 6"x6"x88" (152x152x2235)



B1 JOIST END - A4M01610
(2) 1 3/8"x5 1/4"x60 1/2" (36x134x1537)



B2 JOIST END - A4M01611
(2) 1 3/8"x5 1/4"x60 1/2" (36x134x1537)



B3 JOIST - A4M01596
(2) 1 3/8"x5 1/4"x71 1/4" (36x134x1811)



C1 JOIST END - A4M01612
(2) 1 3/8"x5 1/4"x72 1/8" (36x134x1831)



C2 JOIST END - A4M01613
(2) 1 3/8"x5 1/4"x72 1/8" (36x134x1831)



D1 JOIST END - A4M01614
(8) 1 5/8"x3 1/8"x72 1/8" (40x80x1831)



D2 JOIST END - A4M01615
(24) 1 5/8"x3 1/8"x72 1/8" (40x80x1831)

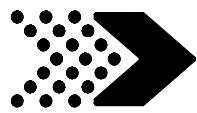

Metal Components (Not to Scale)



J1 | SPLICE BRACKET - A4M01269
(4) | 1 1/4"x5 1/8"x19 5/8" (33x131x500)



J2 | SPLICE BRACKET - A4M01270
(2) | 1 1/4"x5 1/8"x15 3/4" (33x131x400)



J3 | SPLICE BRACKET - A4M01271
(16) | 1 1/2"x3"x15 3/4" (37x77x400)

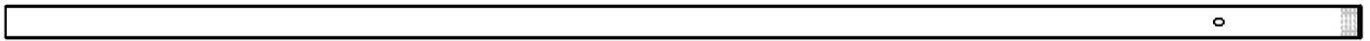

E1 | PURLIN END - A4M01272
(24) | 3/4"x1 5/8"x65 3/4" (20x40x1670)



E2 | PURLIN - A4M01277
(12) | 3/4"x1 5/8"x60 3/8" (20x40x1534)

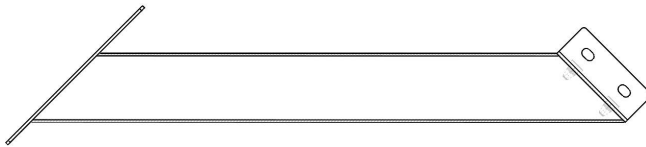

F1 | LONG ANGLE BRACE - A4M01273
(2) | 1 1/8"x4"x21 1/2" (30x101x546)

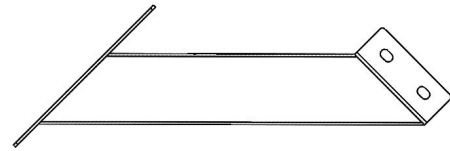

F3 | SHORT ANGLE BRACE - A4M01275
(2) | 1 1/8"x4"x14" (30x101x355)

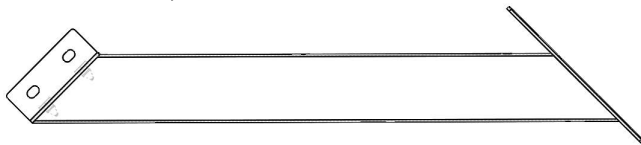

F2 | LONG ANGLE BRACE - A4M01274
(2) | 1 1/8"x4"x21 1/2" (30x101x546)

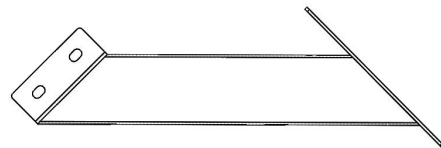

F4 | SHORT ANGLE BRACE - A4M01276
(2) | 1 1/8"x4"x14" (30x101x355)



Hardware Components

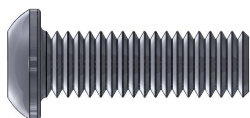

H101101 | TORX PAN HEAD
(242) | 1/4-20x3/4"

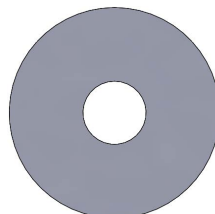

H101053 | STEEL WASHER
(322) | 6x20

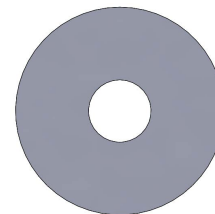

H101054 | SEALANT WASHER
(322)



H101107 | TORX PAN HEAD
(50) | 1/4-20x1 1/2"

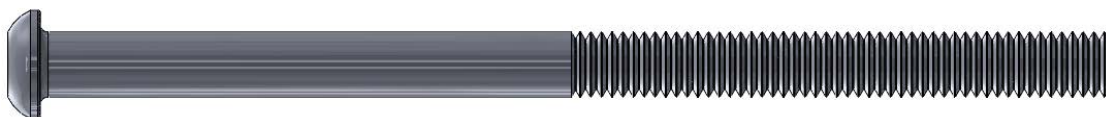

H101102 | TORX PAN HEAD
(34) | 1/4-20x4"



H101103 | TORX SOCKET SCREW
(34) | 1/4-20



H100120 | SCREW CONCRETE ANCHOR
(17) | 1/4x2



H100630 | WASHER FLAT BLK
(17) | 8x19

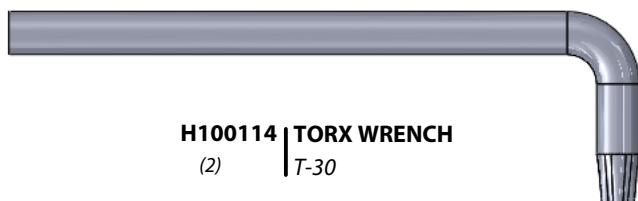

H100114 | TORX WRENCH
(2) | T-30

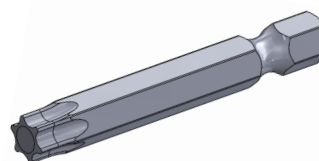

H100147 | TORX BIT
(2) | T-30

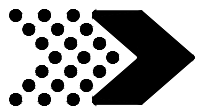

Accessory Components (Not to Scale)

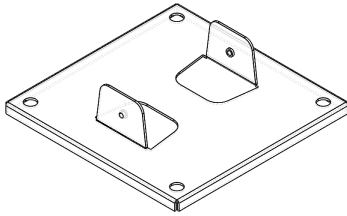

G1 POST FOOT PLATE - A4M01278
(4) | 2 1/8"x8 3/8"x8 3/8" (54x213x213)

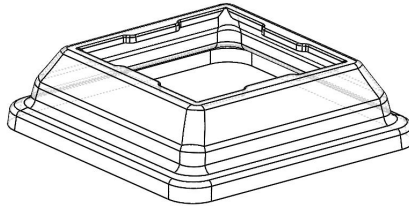

G2 POST FOOT - A4M01279
(4) | 2 5/8"x9 7/8"x9 7/8" (68x250x250)

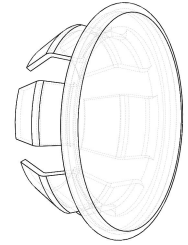

H1 HOLE COVER - A4M01352
(32)

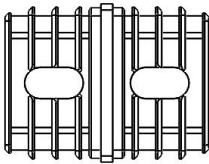

H2 2-WAY SQUARE PLUG- A6P00465
(24) | 3/4"x1 5/8"x2" (20x40x52)

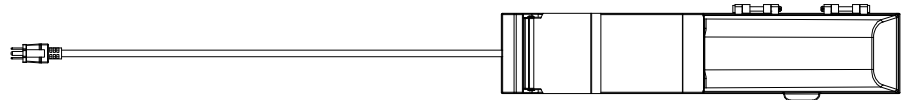

9205413 | ELECTRICAL ENCLOSURE
(x1)

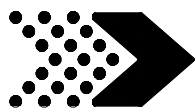

PRE-ASSEMBLY STEP 1

SORTING PARTS



ASSEMBLY TIP:

Keep an eye out for these boxes which will contain helpful pictures and information making the assembly process as quick and painless as possible.

Sorting Parts

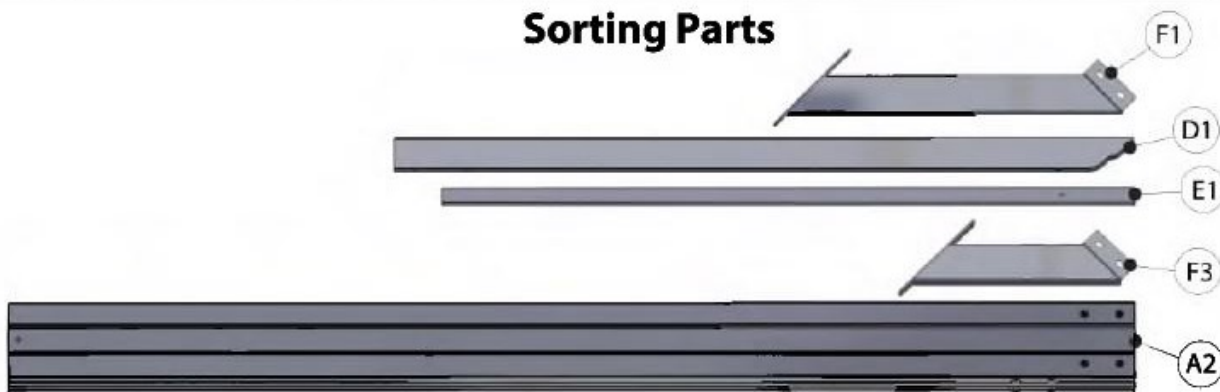

When removing the parts from the boxes we recommend arranging them by part number before you begin assembly. This will allow for faster assembly and easily identify any parts that may be missing or damaged.

Hardware is identified with a seven digit alpha-numeric part number. During assembly you only need to reference the last three digits of the part number as noted in each step. This will make finding the correct hardware easier.

Hardware Identification

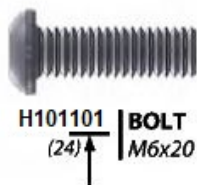

053 (x4)
STEEL WASHER - 6x20

054 (x4)
RUBBER WASHER - 6x20

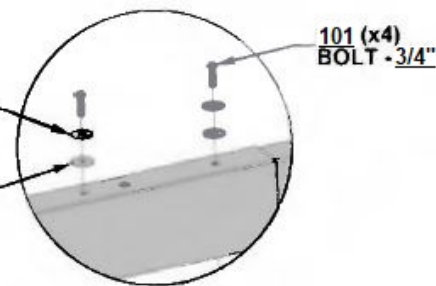

Tools Required



Some steps in the assembly process will require a second set of hands. Make sure you have a helper available.



You will need to make sure that your assembly is square before fully tightening your bolts.



For proper assembly you will need to ensure that your structure is level before proceeding to the next step.



A tape measure may be needed to check overall dimensions to ensure structure is square.



A ladder will be needed for assembly. DO NOT stand or climb on any part of the structure at any point. Doing so may result in injury.

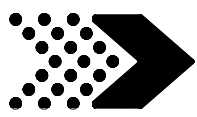

PRE-ASSEMBLY STEP 2 CHOOSE YOUR ASSEMBLY METHOD

There are several types of assembly instructions available to you.

1. Printed Assembly Manual included with your set
2. BILT APP - 3D interactive instructions
3. Combination of the Printed Manual and BILT APP (Note: Step numbers can differ between the two methods)

BILT.

**Scan for easy
3D instructions**

Download the BILT app
before you begin

Download on the
App Store

GET IT ON
Google Play

The advertisement features the BILT logo at the top left, a QR code at the top right, and two buttons for downloading the app on the App Store and Google Play. Below this is a smartphone displaying the BILT app interface, which shows a 3D assembly diagram of a structure with a horizontal beam and a triangular support. The app interface includes a 'Hardware Needed' label, a close button (X), a menu button (three dots), a back button (left arrow), a play/pause button (II), and a forward button (right arrow). The number '17' is visible in the bottom left corner of the app screen.

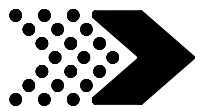

PERGOLA ASSEMBLY

STEP 1

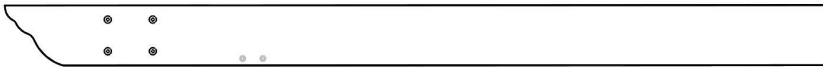

C1 JOIST END - A4M01612

(2) 1 3/8"x5 1/4"x72 1/8" (36x134x1831)



J2 SPLICE BRACKET - A4M01270

(2) 1 1/4"x5 1/8"x15 3/4" (33x131x400)

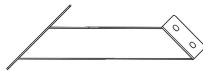

F3 SHORT ANGLE BRACE - A4M01275

(2) 1 1/8"x4"x14" (30x101x355)

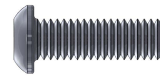

H101101 TORX PAN HEAD
(16) 1/4-20x3/4"



H101053 STEEL WASHER
(16) 6x20



H101054 SEALANT WASHER
(16)

 **DO NOT FULLY TIGHTEN BOLTS AT THIS STEP.**

**J2 (x1)
SPLICE BRACKET**

**C1 (x1)
JOIST END**

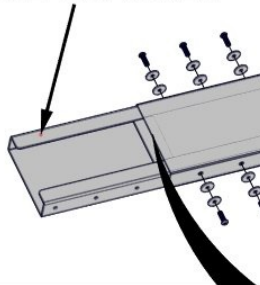

**101 (x8)
BOLT - 3/4"**

**F3 (x1)
SHORT ANGLE BRACE**

J2 SLIDES INTO C1. LINE UP THREE HOLES ON J2 WITH THREE HOLES ON C1 AND INSERT BOLTS TOP AND BOTTOM.

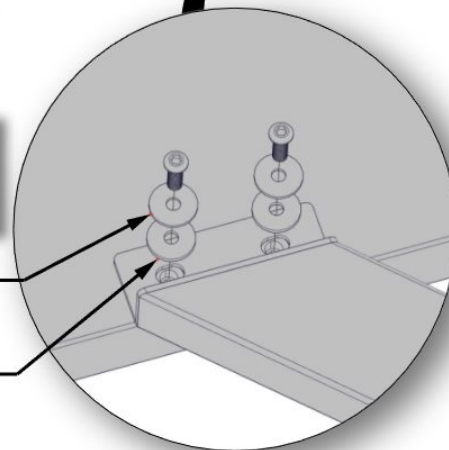

**053 (x8)
STEEL WASHER - 6x20**

**054 (x8)
SEALANT WASHER**

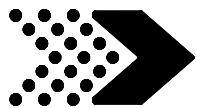

COMPLETE THIS STEP TWICE.



- 
H101101 | TORX PAN HEAD
 (16) | 1/4-20x3/4"
- 
H101053 | STEEL WASHER
 (16) | 6x20
- 
H101054 | SEALANT WASHER
 (16)

C2 | JOIST END - A4M01613

(2) | 1 3/8"x5 1/4"x72 1/8" (36x134x1831)

F4 | SHORT ANGLE BRACE - A4M01276

(2) | 1 1/8"x4"x14" (30x101x355)

SLIDE C2 ONTO SPLICE BRACKET. STAND UP ASSEMBLY ON END WITH PACKAGING CARDBOARD ON GROUND. TAP UNTIL GAP IS GONE THEN TIGHTEN ALL BOLTS ON JOIST.

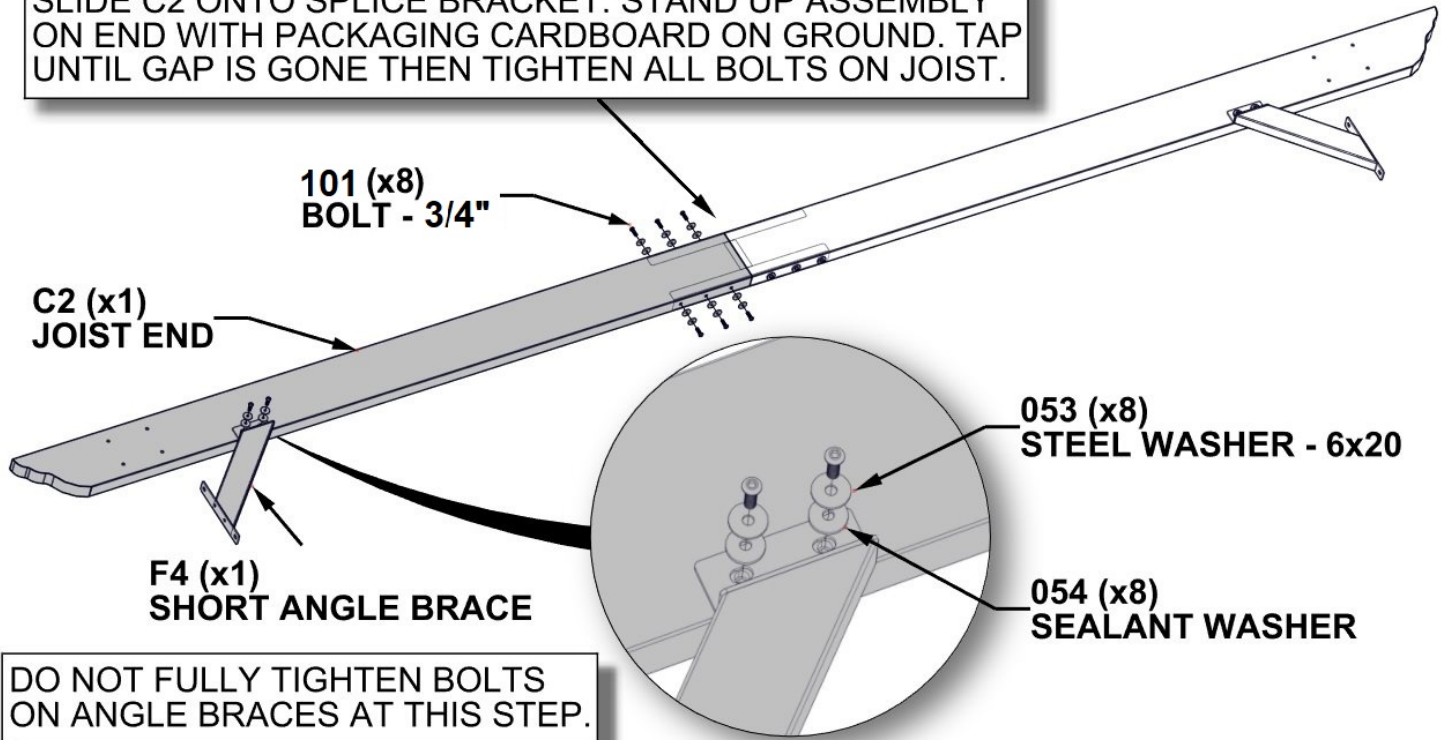

**101 (x8)
BOLT - 3/4"**

**C2 (x1)
JOIST END**

**F4 (x1)
SHORT ANGLE BRACE**

**053 (x8)
STEEL WASHER - 6x20**

**054 (x8)
SEALANT WASHER**

DO NOT FULLY TIGHTEN BOLTS ON ANGLE BRACES AT THIS STEP.

COMPLETE THIS STEP TWICE.

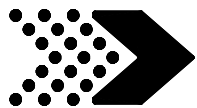

A1 POST - A4M01565
(2) | 6"x6"x88" (152x152x2235)

A2 POST - A4M01566
(2) | 6"x6"x88" (152x152x2235)

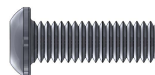
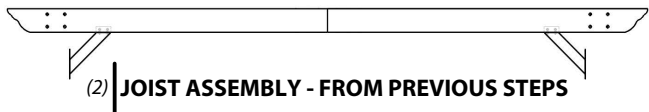

H101101 | TORX PAN HEAD
(8) | 1/4-20x3/4"



H101053 | STEEL WASHER
(8) | 6x20



H101103 | TORX SOCKET SCREW
(16) | 1/4x20



H101054 | SEALANT WASHER
(8)



LAY PARTS ON GROUND OR SAW HORSES FOR EASE OF ASSEMBLY.

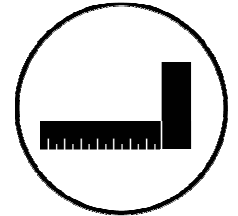

**103 (x8)
BOLT - 1/4x20**

ENSURE UPPER BOLT HOLES ARE FACING OUT ON POSTS.

JOIST ASSEMBLY (x1)

**101 (x4)
BOLT - 3/4"**

**053 (x4)
STEEL WASHER - 6x20**

**A1 (x1)
POST**

**A2 (x1)
POST**

SQUARE UP POSTS TO JOIST AND FULLY TIGHTEN ALL BOLTS.

**054 (x4)
SEALANT WASHER**

REPEAT THIS STEP FOR OTHER UPRIGHT ASSEMBLY.

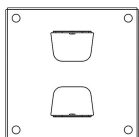

G1 | **POST FOOT PLATE - A4M01278**
(4) | 2 1/8"x8 3/8"x8 3/8" (54x213x213)

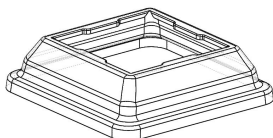

G2 | **POST FOOT - A4M01279**
(4) | 2 5/8"x9 7/8"x9 7/8" (68x250x250)



H101101 | **TORX PAN HEAD**
(8) | 1/4-20x3/4"



H101053 | **STEEL WASHER**
(8) | 6x20



H101054 | **SEALANT WASHER**
(8)



SLIDE A POST FOOT ONTO EACH POST THEN BOLT ON POST FOOT PLATES TO EACH POST. VERTICAL TAB ON POST FOOT PLATE LINES UP WITH HOLES ON SIDE OF POST.

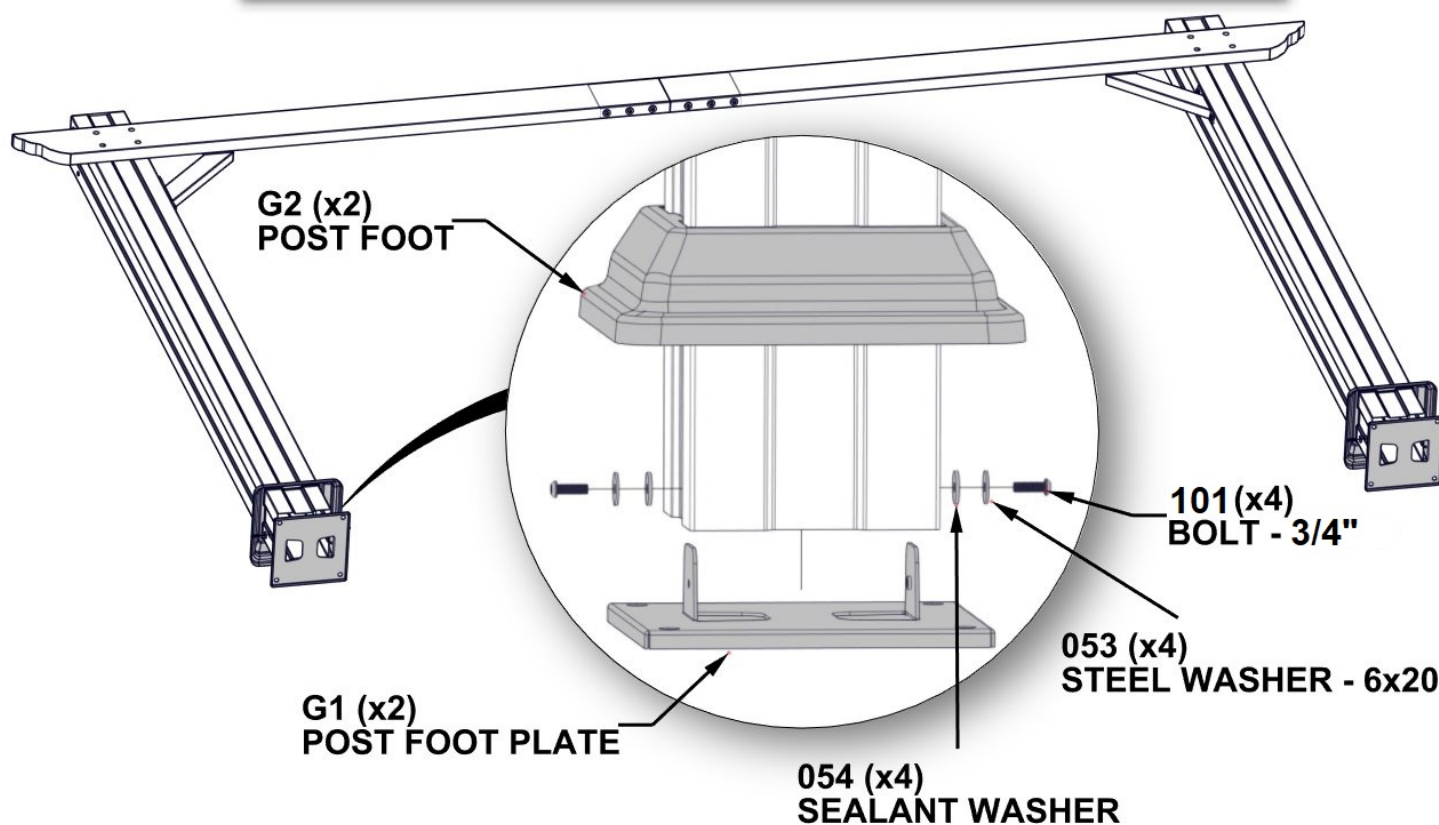

REPEAT THIS STEP FOR OTHER UPRIGHT ASSEMBLY.



B3 JOIST - A4M01596
(2) 1 3/8"x5 1/4"x71 1/4" (36x134x1811)



J1 SPLICE BRACKET - A4M01269
(4) 1 1/4"x5 1/8"x19 5/8" (33x131x500)

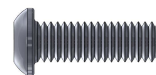

H101101 TORX PAN HEAD
(24) 1/4-20x3/4"



H101053 STEEL WASHER
(24) 6x20



H101054 SEALANT WASHER
(24)



DO NOT FULLY TIGHTEN BOLTS AT THIS STEP.



DO NOT INSERT A BOLT INTO THE LARGER HOLE ON EITHER END.

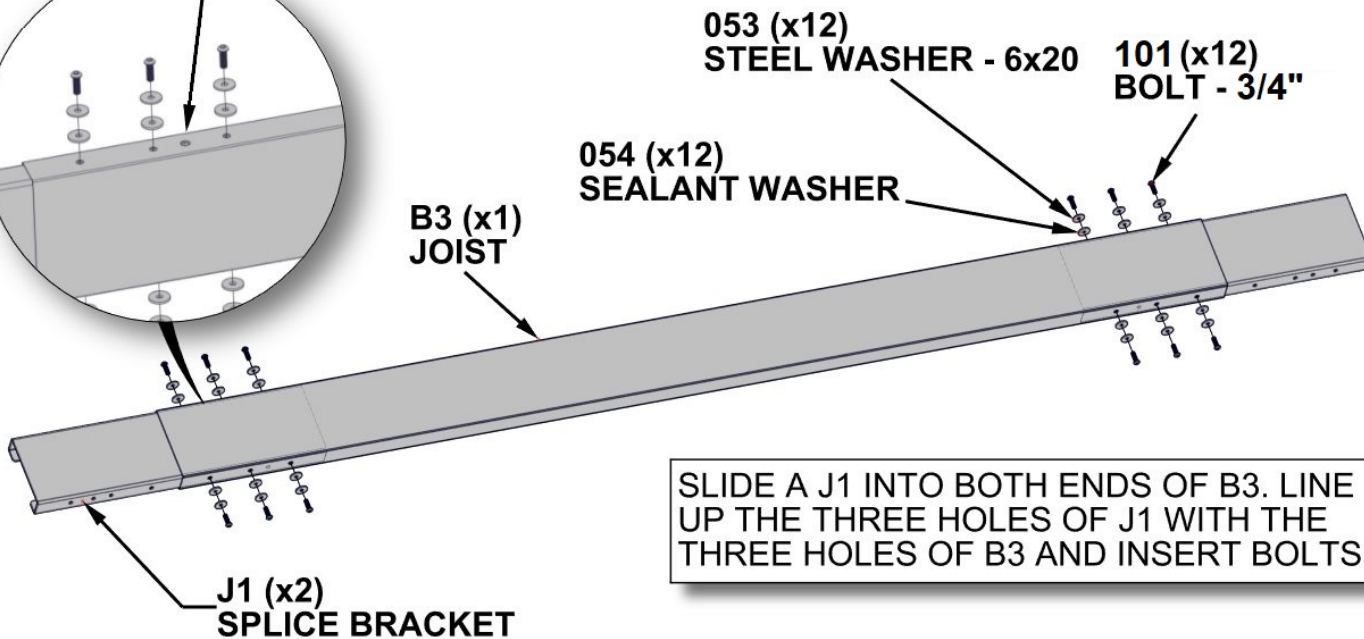
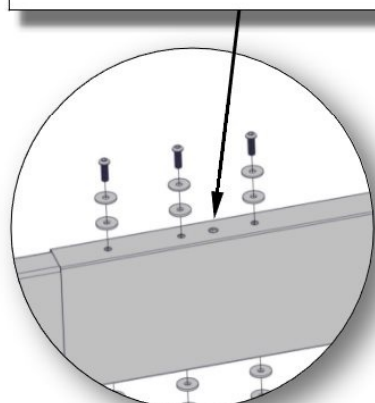

SLIDE A J1 INTO BOTH ENDS OF B3. LINE UP THE THREE HOLES OF J1 WITH THE THREE HOLES OF B3 AND INSERT BOLTS.

REPEAT THIS STEP FOR OTHER JOIST.



PERGOLA ASSEMBLY

STEP 6



B1 JOIST END - A4M01610

(2) 1 3/8"x5 1/4"x60 1/2" (36x134x1537)

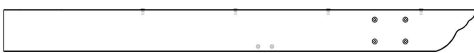

B2 JOIST END - A4M01611

(2) 1 3/8"x5 1/4"x60 1/2" (36x134x1537)

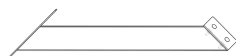

F1 LONG ANGLE BRACE - A4M01273

(2) 1 1/8"x4"x21 1/2" (30x101x546)

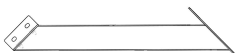

F2 LONG ANGLE BRACE - A4M01274

(2) 1 1/8"x4"x21 1/2" (30x101x546)

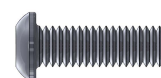

H101101 TORX PAN HEAD
(32) 1/4-20x3/4"



H101053 STEEL WASHER
(32) 6x20



H101054 SEALANT WASHER
(32)

SLIDE B1 ONTO SPLICE BRACKET. STAND UP ASSEMBLY ON END WITH PACKAGING CARDBOARD ON GROUND. TAP UNTIL GAP IS GONE THEN TIGHTEN ALL BOLTS. REPEAT WITH B2.

ENSURE BOLT HOLES ARE FACING UP ON B3.

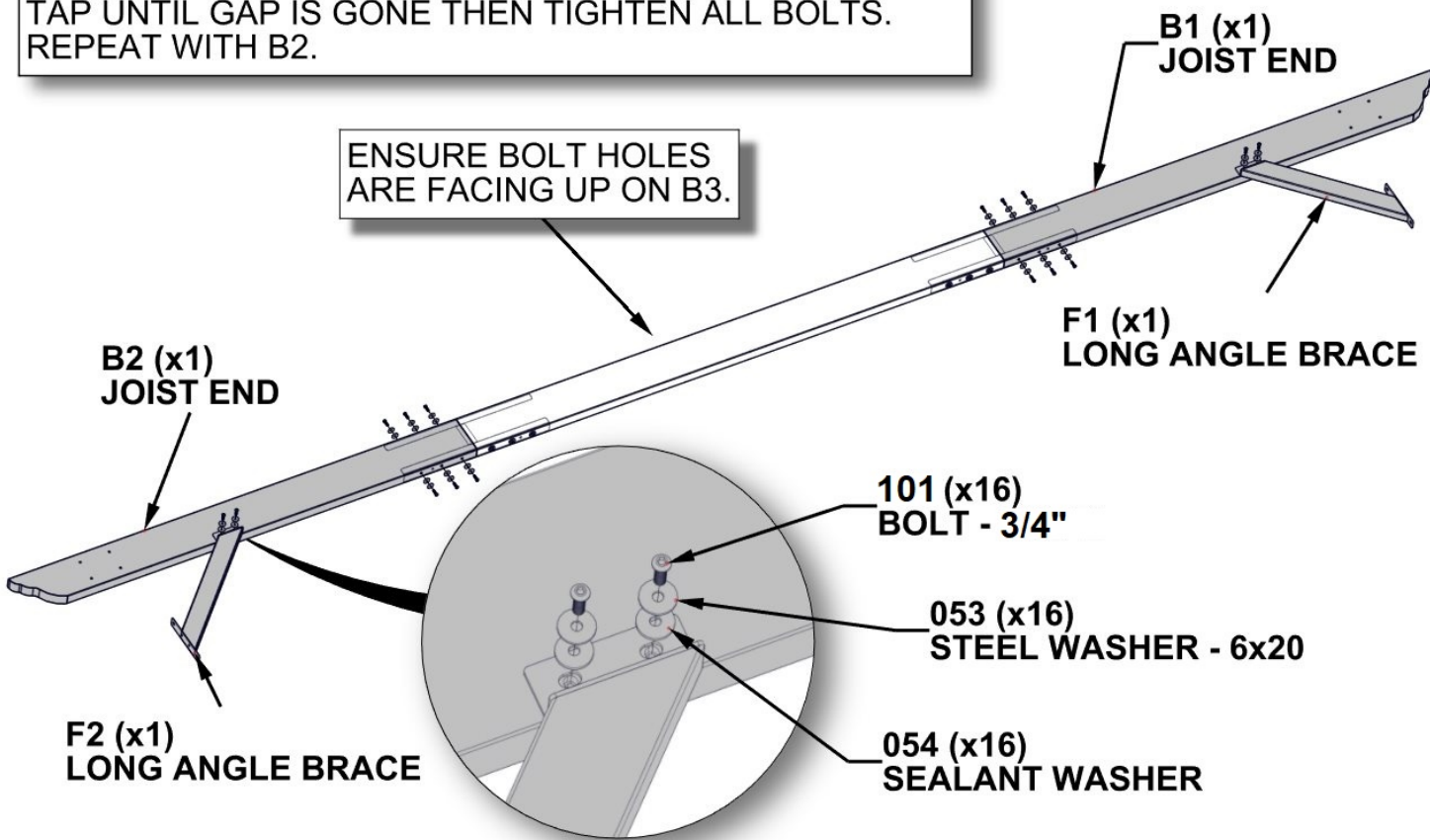

DO NOT FULLY TIGHTEN BOLTS ON ANGLE BRACES AT THIS STEP.

REPEAT THIS STEP FOR OTHER JOIST ASSEMBLY.

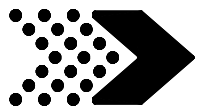

PERGOLA ASSEMBLY

STEP 7

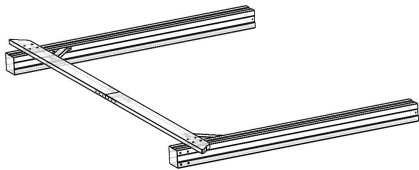

(2) UPRIGHT ASSEMBLY - FROM PREVIOUS STEPS

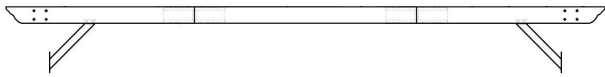

(2) JOIST ASSEMBLY - FROM PREVIOUS STEPS

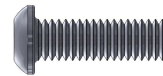

H101101 TORX PAN HEAD
(8) 1/4-20x3/4"



H101103 TORX SOCKET SCREW
(16) 1/4-20



H101053 STEEL WASHER
(8) 6x20



H101054 SEALANT WASHER
(8)

WITH BOTH UPRIGHT ASSEMBLIES STANDING, ONE JOIST ASSEMBLY IS BOLTED ON WITHOUT FULLY TIGHTENING BOLTS. ONCE ONE JOIST ASSEMBLY IS BOLTED ON, BOLT ON SECOND JOIST ASSEMBLY.



JOIST ASSEMBLY (x2)

UPRIGHT ASSEMBLY (x2)

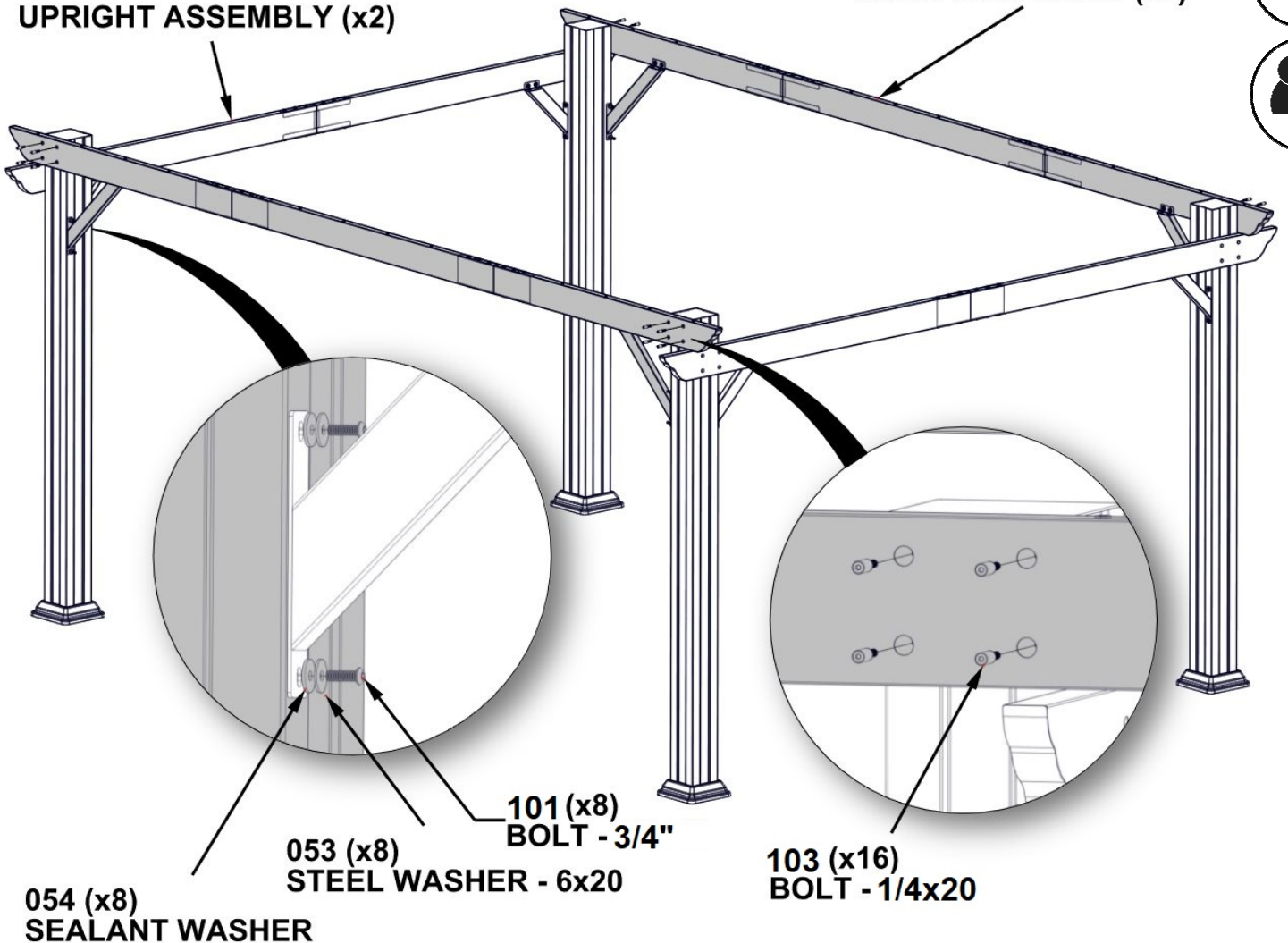

SQUARE UP ALL POSTS TO JOIST ASSEMBLIES AND FULLY TIGHTEN ALL BOLTS.

NOTE: A THIRD PERSON IS HELPFUL FOR THIS STEP.

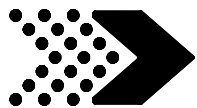

D1 | JOIST END - A4M01614
 (4) | 1 5/8"x3 1/8"x72 1/8" (40x80x1831)

J3 | SPLICE BRACKET - A4M01271
 (4) | 1 1/2"x3"x15 3/4" (37x77x400)

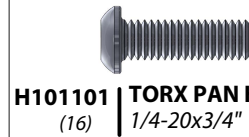

H101101 | TORX PAN HEAD
 (16) | 1/4-20x3/4"



H101053 | STEEL WASHER
 (16) | 6x20



H101054 | SEALANT WASHER
 (16)

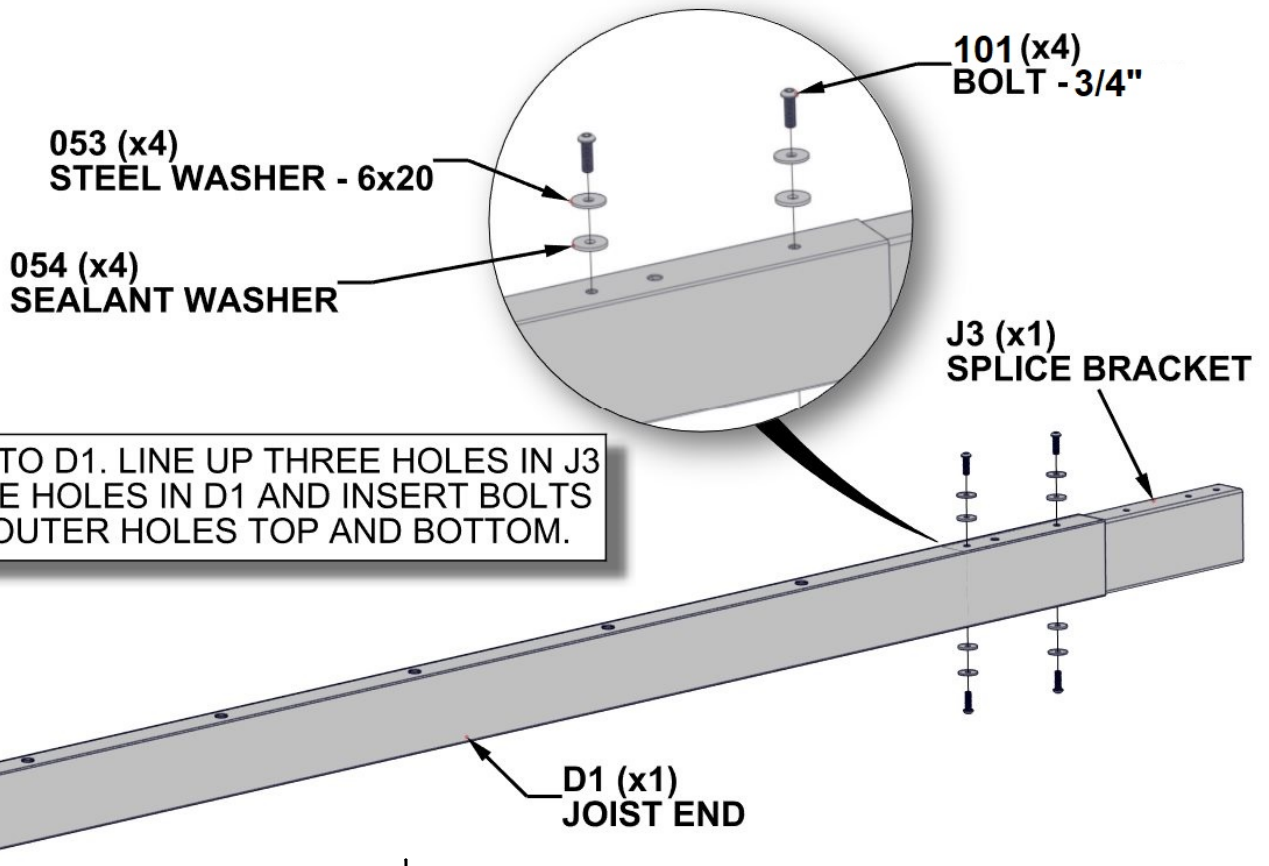

SLIDE J3 INTO D1. LINE UP THREE HOLES IN J3 WITH THREE HOLES IN D1 AND INSERT BOLTS INTO TWO OUTER HOLES TOP AND BOTTOM.



DO NOT FULLY TIGHTEN BOLTS AT THIS STEP.

COMPLETE THIS STEP FOUR TIMES.



D1 JOIST END - A4M01614
(4) | 1 5/8"x3 1/8"x72 1/8" (40x80x1831)



H101101 TORX PAN HEAD
(16) | 1/4-20x3/4"



H101053 STEEL WASHER
(16) | 6x20



H101054 SEALANT WASHER
(16)

SLIDE D1 ONTO SPLICE BRACKET. STAND UP ASSEMBLY ON END WITH PACKAGING CARDBOARD ON GROUND. TAP UNTIL GAP IS GONE THEN TIGHTEN ALL BOLTS ON JOIST.

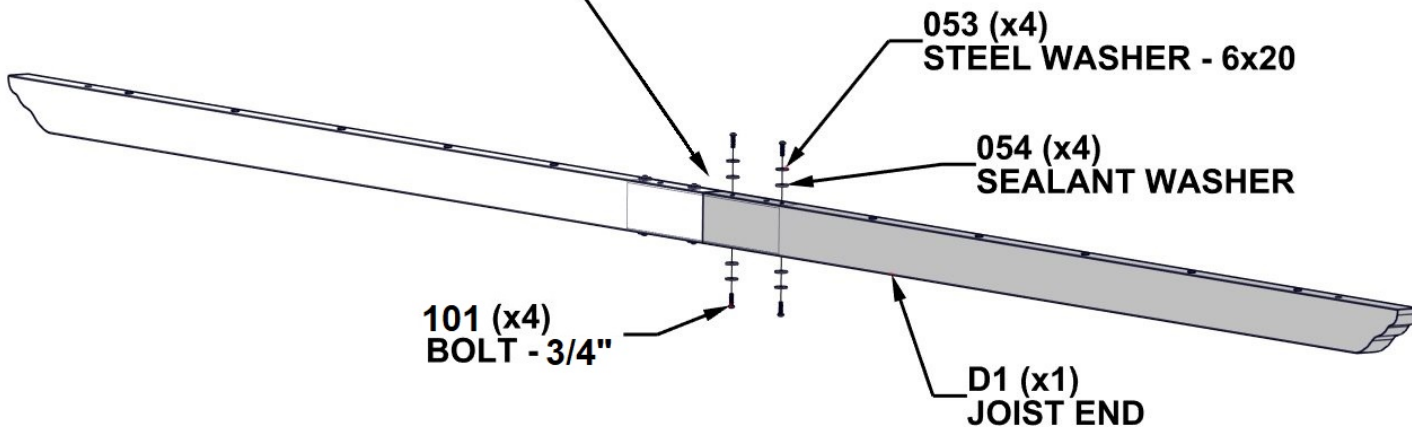

COMPLETE THIS STEP FOUR TIMES.

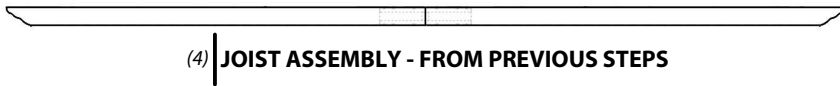
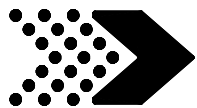

BOLT ONE SIDE OF JOISTS FIRST THEN BOLT OTHER SIDE. DO NOT FULLY TIGHTEN BOLTS AT THIS STEP.

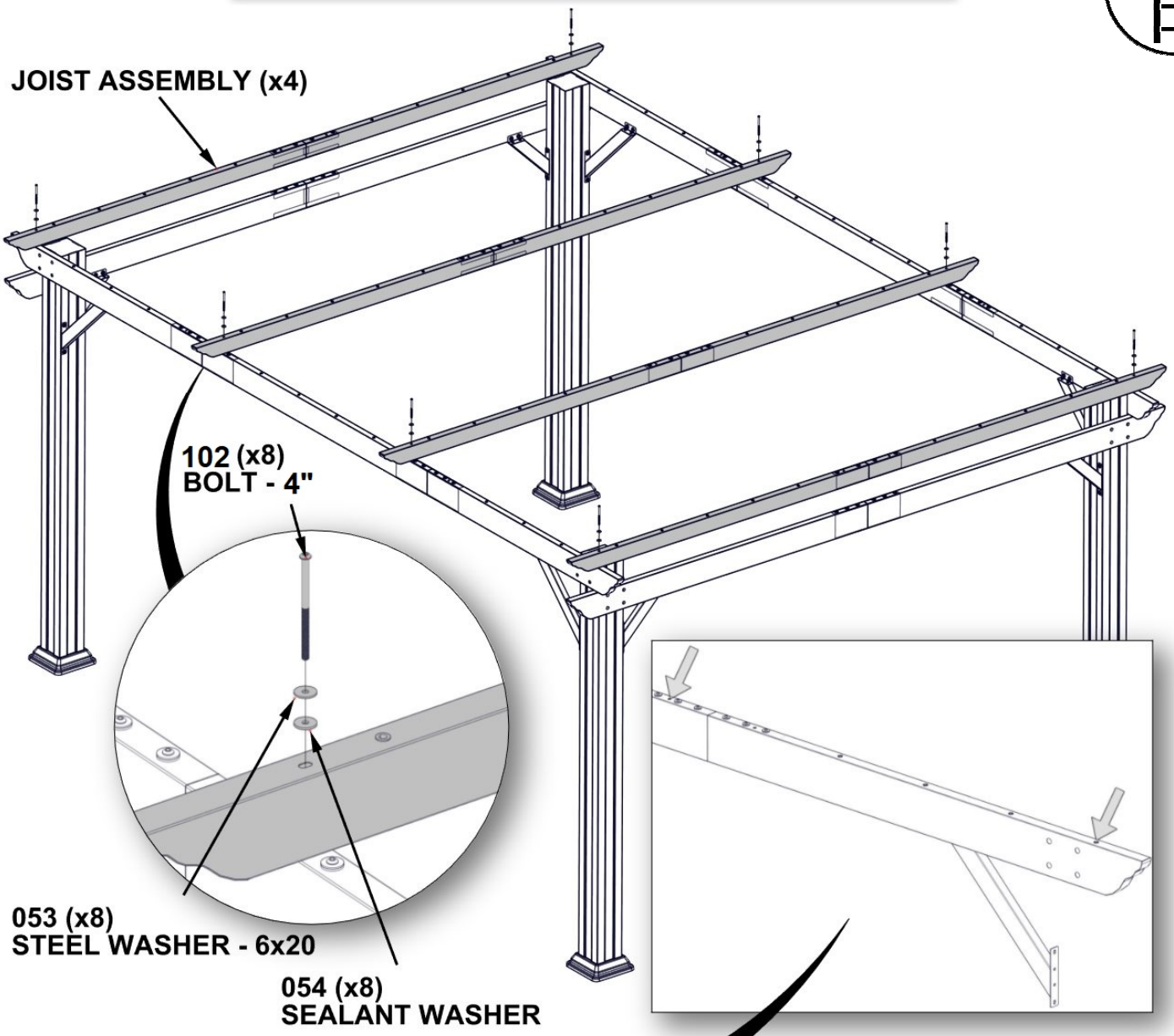

ENSURE JOIST ASSEMBLIES ARE SPACED OUT CORRECTLY AS PLACEMENT IS CRITICAL FOR PURLIN ATTACHMENT.

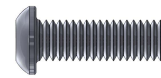
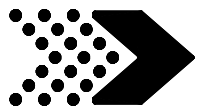

H101101 | TORX PAN HEAD
(48) | 1/4-20x3/4"



H101053 | STEEL WASHER
(48) | 6x20



H101054 | SEALANT WASHER
(48)

D2 | JOIST END - A4M01615

(12) | 1 5/8"x3 1/8"x72 1/8" (40x80x1831)

J3 | SPLICE BRACKET - A4M01271

(12) | 1 1/2"x3"x15 3/4" (37x77x400)

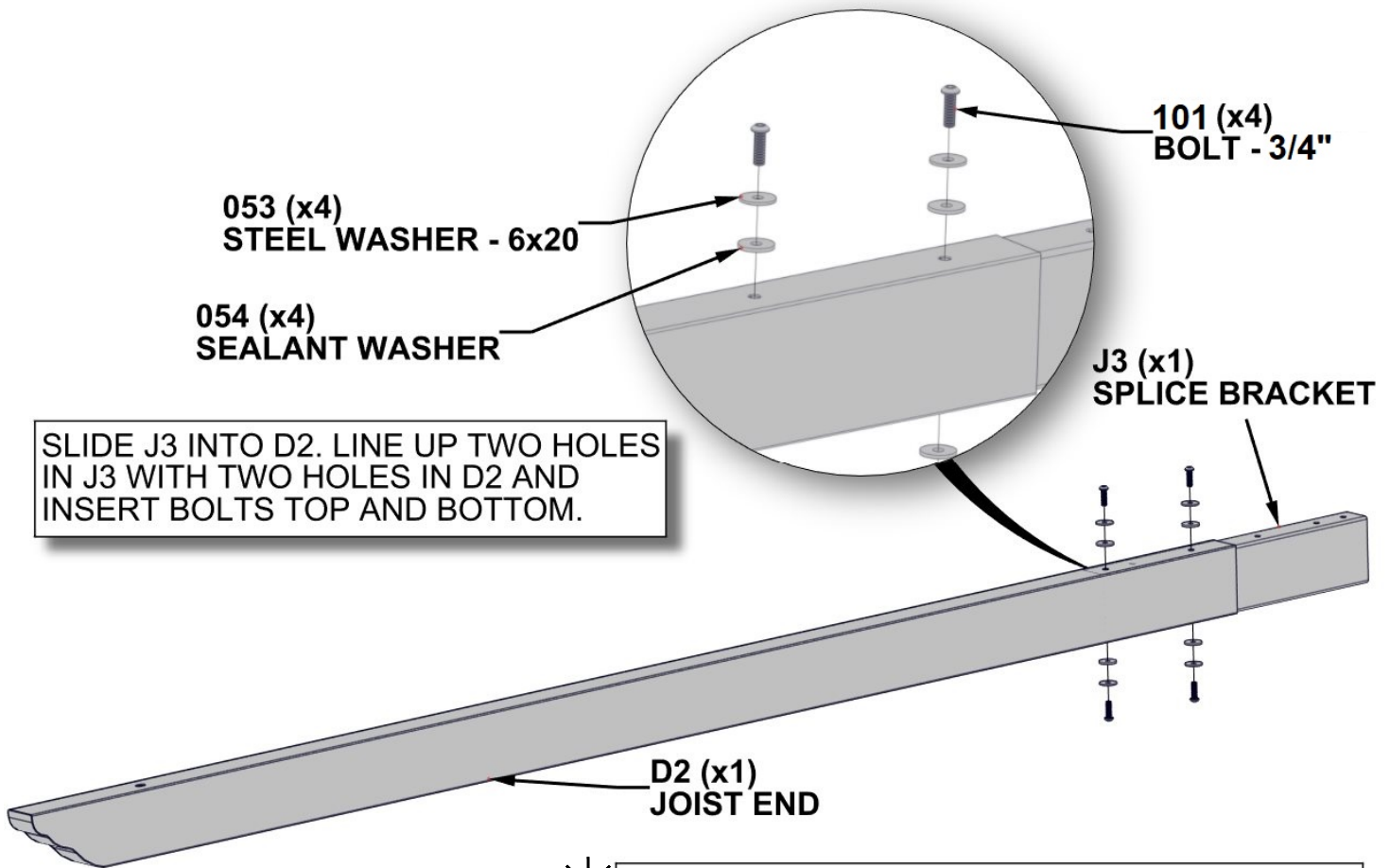

SLIDE J3 INTO D2. LINE UP TWO HOLES IN J3 WITH TWO HOLES IN D2 AND INSERT BOLTS TOP AND BOTTOM.



DO NOT FULLY TIGHTEN BOLTS AT THIS STEP.

COMPLETE THIS STEP TWELVE TIMES.

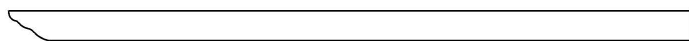

D2 JOIST END - A4M01615
(12) 1 5/8"x3 1/8"x72 1/8" (40x80x1831)

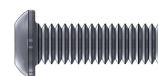

H101101 TORX PAN HEAD
(48) 1/4-20x3/4"



H101053 STEEL WASHER
(48) 6x20



H101054 SEALANT WASHER
(48)

SLIDE D2 ONTO SPLICE BRACKET. STAND UP ASSEMBLY ON END WITH PACKAGING CARDBOARD ON GROUND. TAP UNTIL GAP IS GONE THEN TIGHTEN ALL BOLTS ON JOIST.

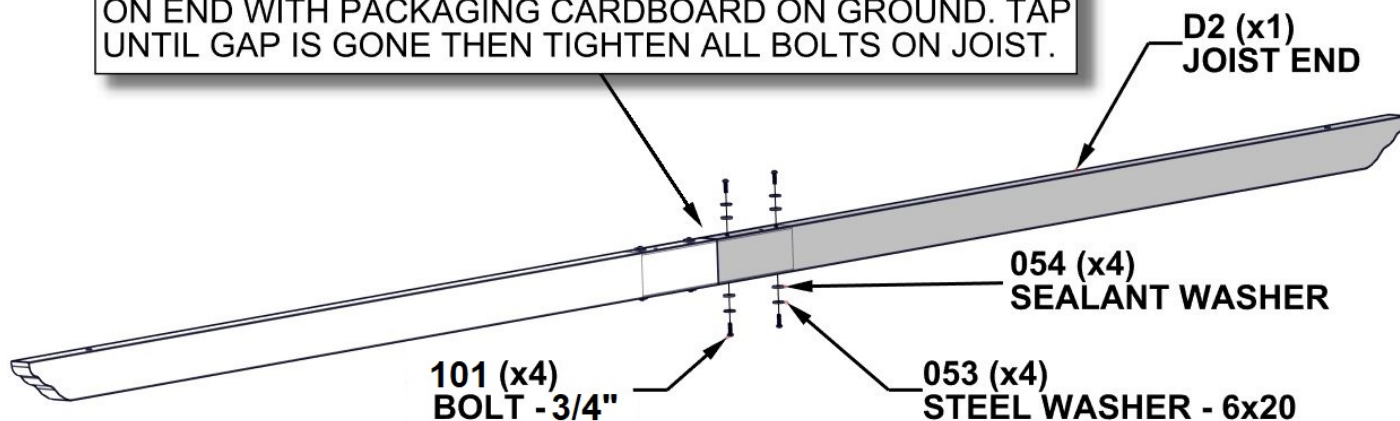

COMPLETE THIS STEP TWELVE TIMES.

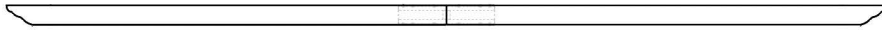
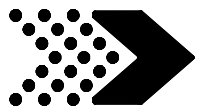

(12) JOIST ASSEMBLY - FROM PREVIOUS STEPS



H101102 | TORX PAN HEAD
(24) | 1/4-20x4"



H101053 | STEEL WASHER
(24) | 6x20



H101054 | SEALANT WASHER
(24)

BOLT ONE SIDE OF JOISTS FIRST THEN BOLT OTHER SIDE. DO NOT FULLY TIGHTEN BOLTS YET.



JOIST ASSEMBLY (x12)

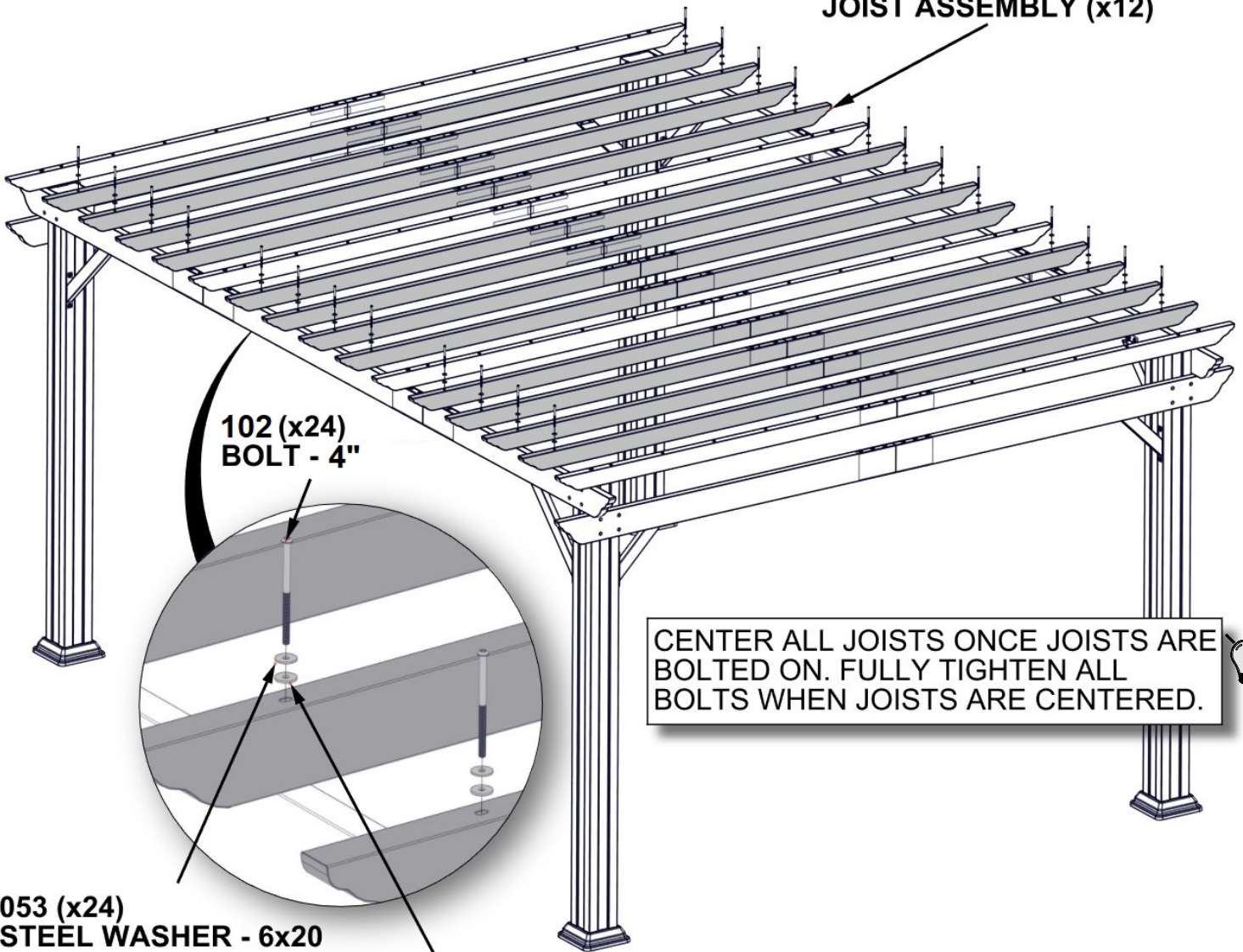

102 (x24)
BOLT - 4"

053 (x24)
STEEL WASHER - 6x20

054 (x24)
SEALANT WASHER

CENTER ALL JOISTS ONCE JOISTS ARE BOLTED ON. FULLY TIGHTEN ALL BOLTS WHEN JOISTS ARE CENTERED.



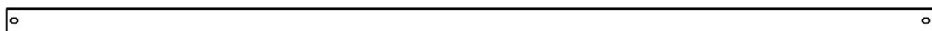

E2 PURLIN - A4M01277
(12) 3/4"x1 5/8"x60 3/8" (20x40x1534)

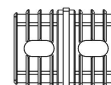

H2 2-WAY SQUARE PLUG- A6P00465
(24) 3/4"x1 5/8"x2" (20x40x52)



SLIDE A 2-WAY SQUARE PLUG INTO EACH END OF PURLIN.

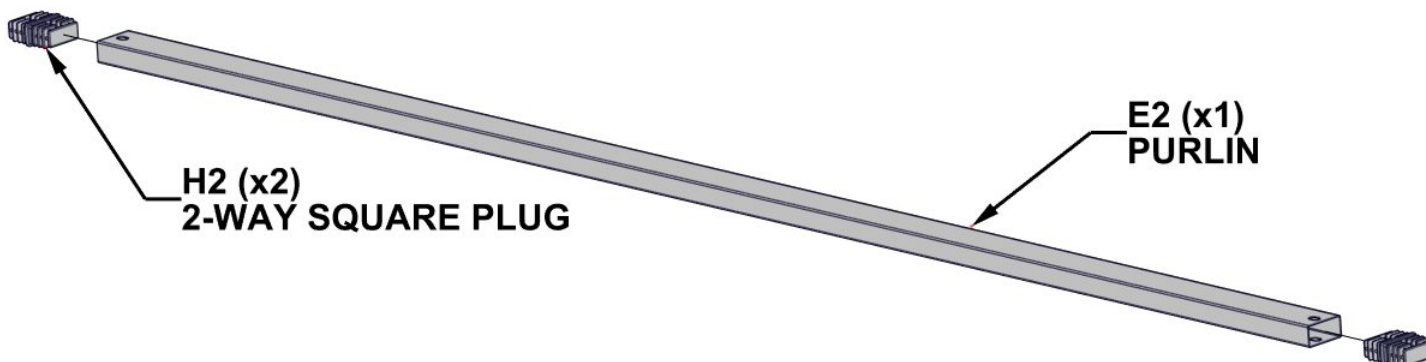

COMPLETE THIS STEP TWELVE TIMES.

NOTE: A RUBBER MALLET MAY BE HELPFUL TO GET THE 2-WAY SQUARE PLUGS INTO THE ENDS OF THE PURLIN.

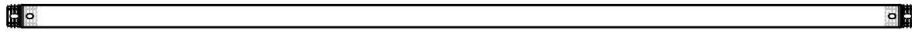
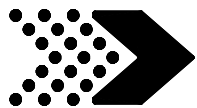

(12) PURLIN ASSEMBLY - FROM PREVIOUS STEPS



H101107 | TORX PAN HEAD
(24) | 1/4-20x1 1/2"



H101053 | STEEL WASHER
(24) | 6x20



H101054 | SEALANT WASHER
(24)

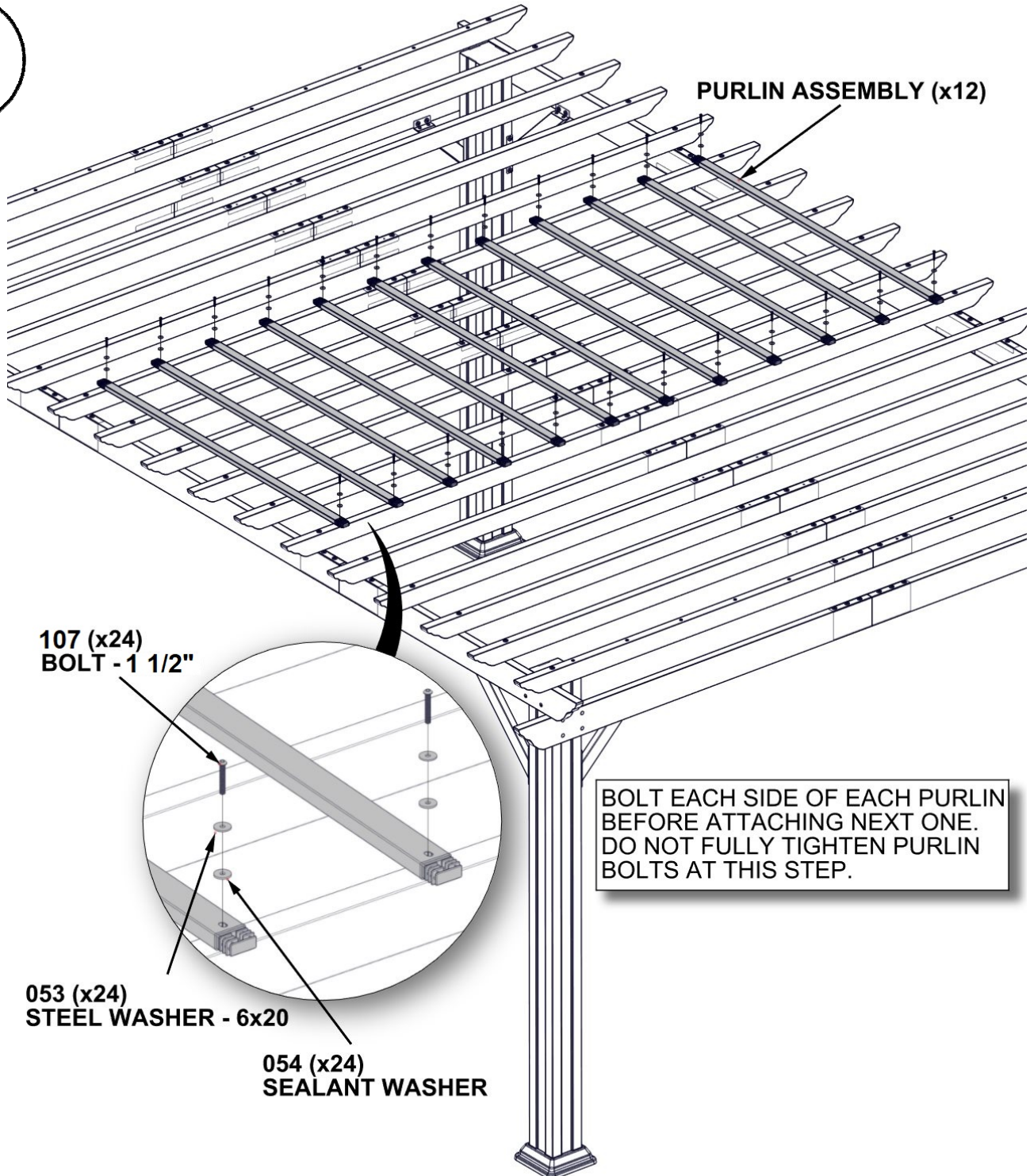
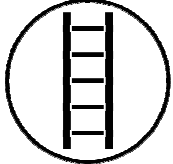

PURLIN ASSEMBLY (x12)

107 (x24)
BOLT - 1 1/2"

053 (x24)
STEEL WASHER - 6x20

054 (x24)
SEALANT WASHER

BOLT EACH SIDE OF EACH PURLIN BEFORE ATTACHING NEXT ONE. DO NOT FULLY TIGHTEN PURLIN BOLTS AT THIS STEP.

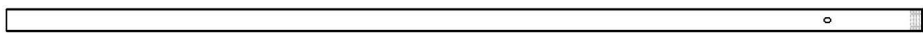

E1 PURLIN END - A4M01272
(24) 3/4"x1 5/8"x65 3/4" (20x40x1670)



H101107 TORX PAN HEAD
(24) 1/4-20X1 1/2"



H101053 STEEL WASHER
(24) 6x20



H101054 SEALANT WASHER
(24)



NOTE: A RUBBER Mallet MAY BE HELPFUL TO GET THE PURLIN ENDS ONTO THE 2-WAY SQUARE PLUGS.

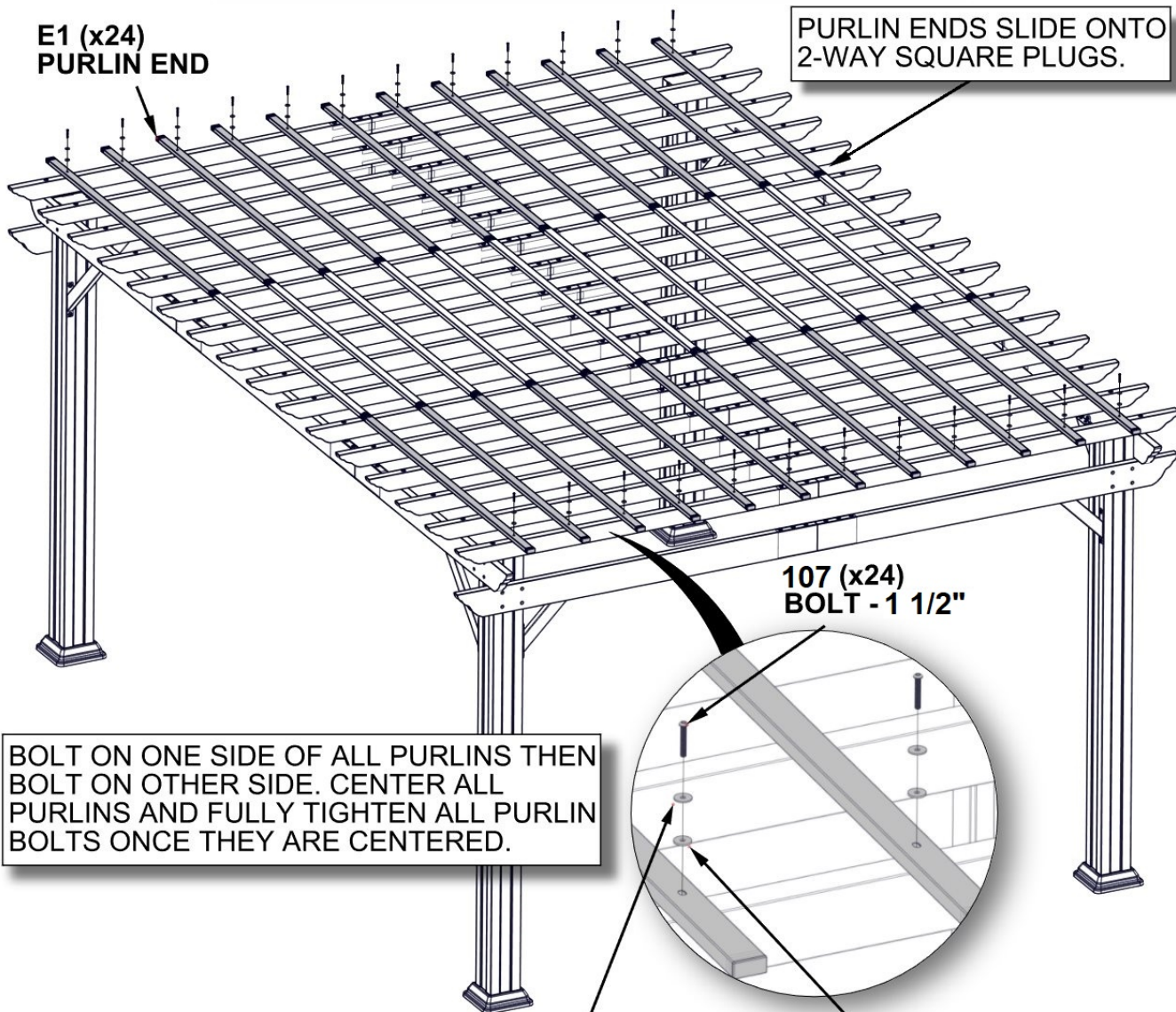

 BOLT ON ONE SIDE OF ALL PURLINS THEN BOLT ON OTHER SIDE. CENTER ALL PURLINS AND FULLY TIGHTEN ALL PURLIN BOLTS ONCE THEY ARE CENTERED.

053 (x24) STEEL WASHER - 6x20

054 (x24) SEALANT WASHER



H1 | HOLE COVER - A4M01352
(32)

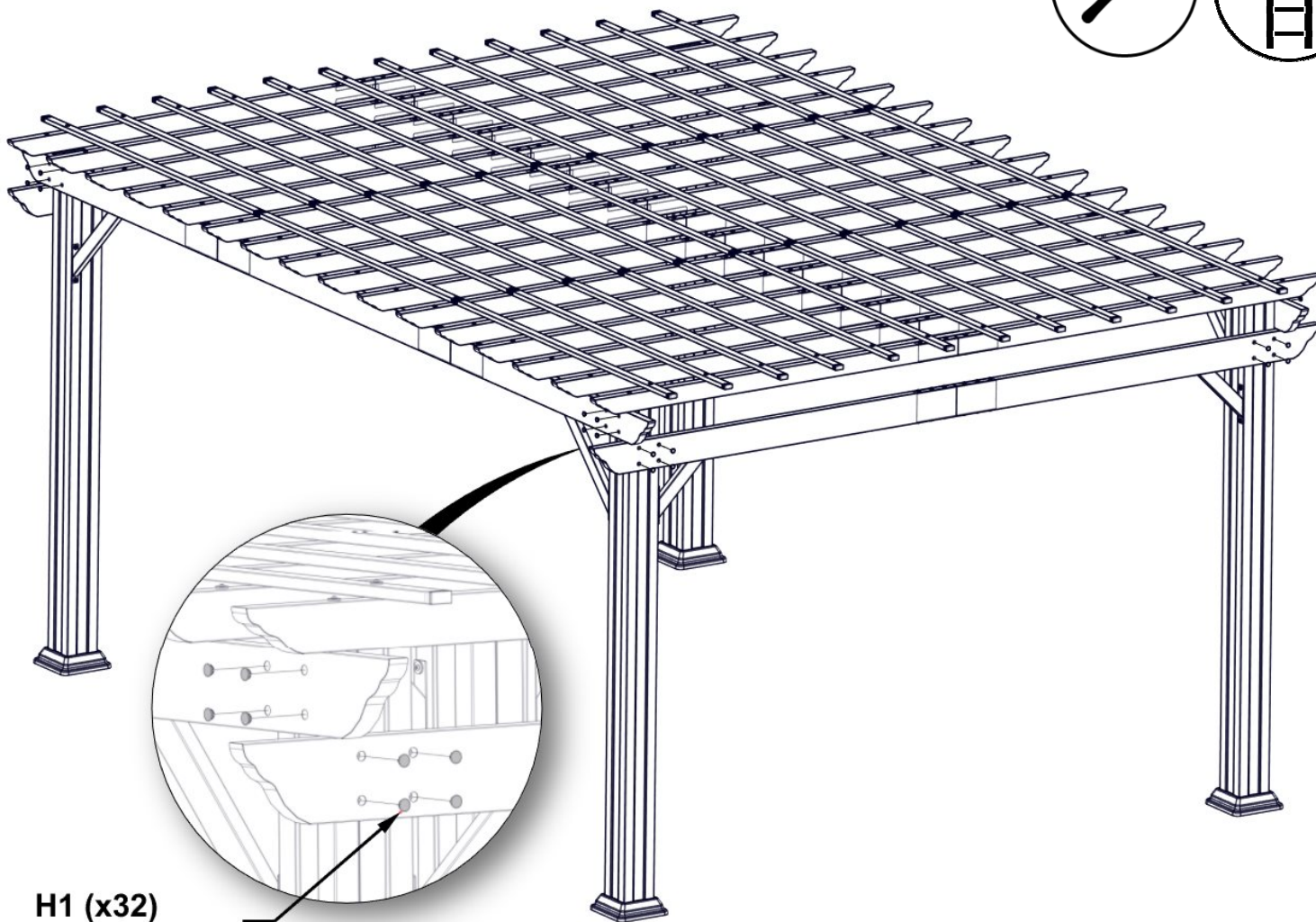

H1 (x32)
HOLE COVER

USE A SMALL PIECE OF WOOD TO TAP HOLE COVERS IN WITH A RUBBER Mallet.



H100120 | SCREW CONCRETE ANCHOR
(16) | 1/4x2



H100630 | WASHER FLAT BLK
(16) | 8x19

MANUFACTURER RECOMMENDS INSTALLATION ON CONCRETE SURFACE OR CONCRETE POST PAD AS SHOWN BELOW.

FOR INSTALLATION ON WOOD DECK, YOU MUST ENSURE THERE IS AMPLE STRUCTURAL SUPPORT UNDER THE DECK. HARDWARE NOT INCLUDED FOR DECK ATTACHMENT.

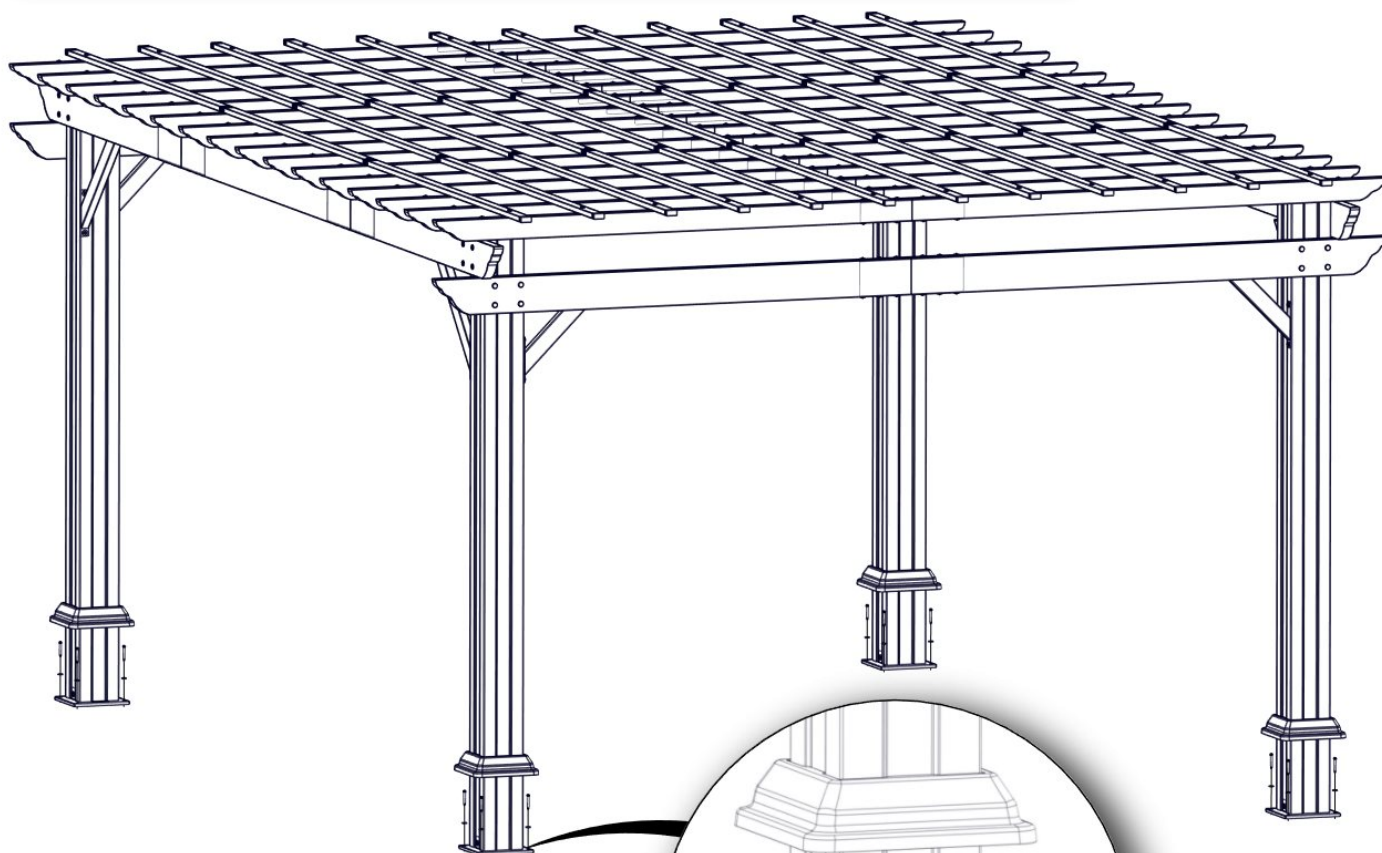

**120 (x16)
SCREW - 2"**

**630 (x16)
WASHER - 8x19**

PRE-DRILL HOLES FOR CONCRETE ANCHORS USING A 3/16" CONCRETE DRILL BIT.

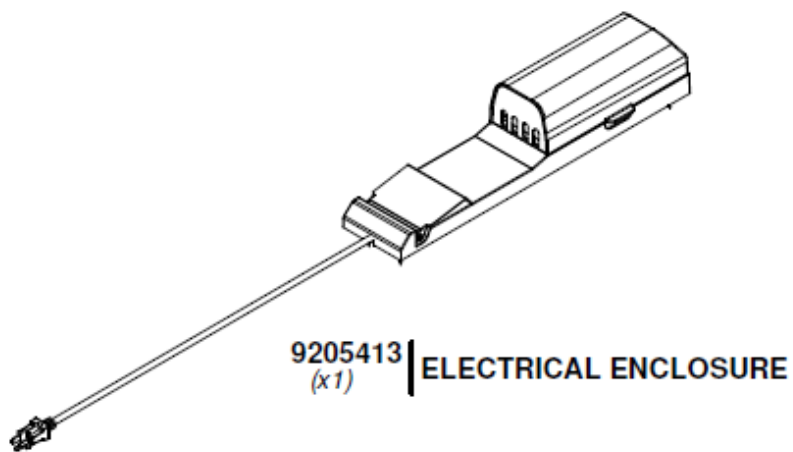

FOR ELECTRICAL ENCLOSURE INSTALLATION REFER TO ASSEMBLY INSTRUCTIONS THAT COMES PACKAGED WITH THE ELECTRICAL ENCLOSURE KIT. INSTALL ON ANY POST THAT IS DESIRED. FOLLOW DIRECTIONS FOR PROPER INSTALLATION.