

BLACK DIAMOND®

Project Name: _____

Location: _____

Item #: _____

Qty: _____

Black Diamond Refrigerated Chef Base, 2 Drawers, 12.7 Cu. Ft. Capacity, in Stainless Steel

USCB-60



Boost efficiency and reliability in your kitchen with the Black Diamond Refrigerated Chef Base. This 60-inch, two-drawer stainless steel base offers a 12.7 Cu. Ft. capacity for versatile food storage. Its fully automatic controller maintains precise temperatures between 33° and 40°F, while R290 refrigerant supports eco-friendly operation. Durable construction doubles as an equipment stand, and the slide-out compressor allows for easy maintenance. Backed by a two-year parts and labor warranty and five-year compressor warranty.

FEATURES AND CONSTRUCTION

- Boasts a 12.7 Cu. Ft. capacity for ample storage needs
- Equipped with a 1/6 HP slide-out compressor mounted for easy maintenance
- Crafted with a stainless steel exterior and drawers for long-lasting durability
- Maintains a temperature range of 33° to 40°F for proper food safety
- Features two stainless steel drawers with smooth tracks and rollers for easy access
- Accommodates up to six full-size pans and two half-long size pans per drawer
- Includes four 4-inch heavy-duty casters for easy mobility and cleaning access
- Measures 60"W x 32.13"D x 25.91"H for versatile undercounter placement
- Slide-out compressor allows easy maintenance
- Foamed-in-place polyurethane insulation enhances efficiency

ELECTRIC

115V / 60Hz / 1Ph

Cord Length (Inches): 98.40"

Plug Type: NEMA 5-15P

Cord set included

NEMA 5-15P



3RD PARTY APPROVALS



WARRANTY (USA / CANADA)

Two (2) Year Limited Warranty on Parts and Labor, Five (5) Year Warranty on Compressor and Evaporator

Contact us for details at 1.877.368.2797



STORAGE CAPACITY

- Cubic Feet: 12.7 Cu. Ft.
- 6 Full Size Pans, 2 Half Long Size Pans

TEMPERATURE

- Holding Temperature (Fahrenheit): 33° - 40°

These models are designed to operate in an environment where temperature and humidity do not exceed 75°F (24°C) and 55% relative humidity



Black Diamond 2 Drawer Refrigerated Chef Base

USCB-60

FRONT

SIDE

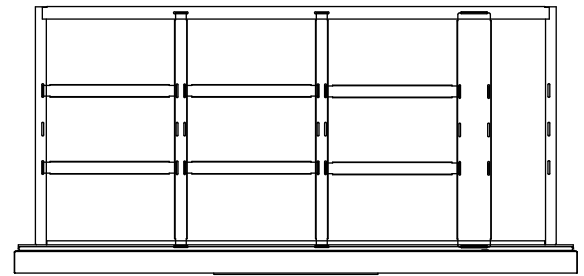
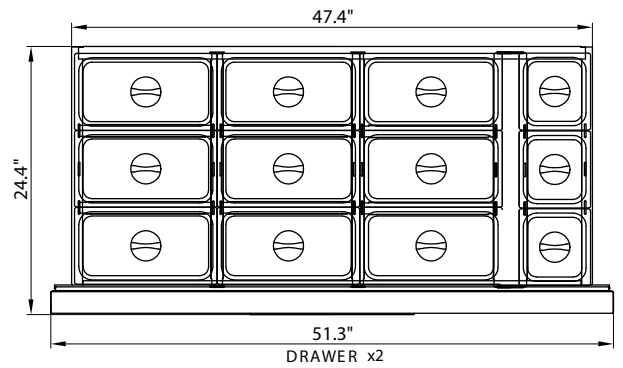
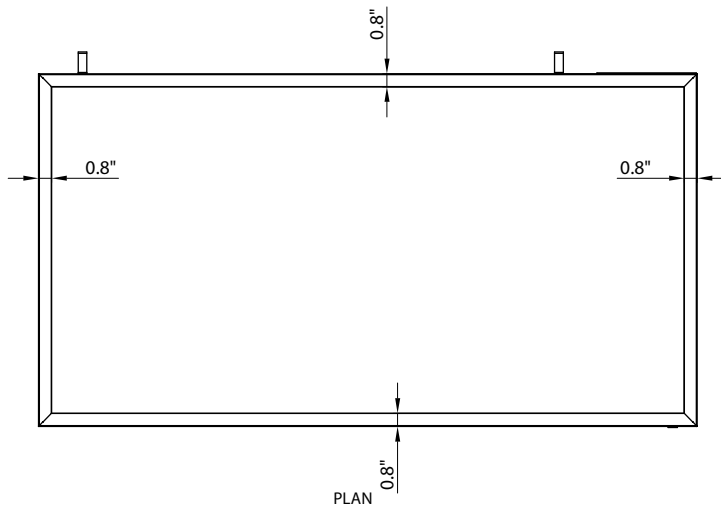
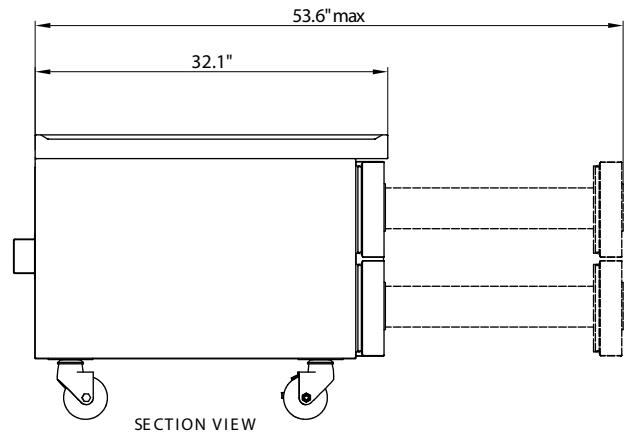
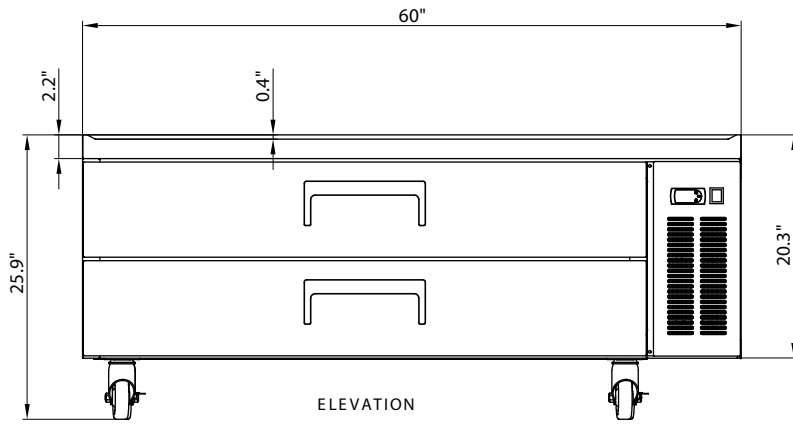

DRAWER(except GN PAN)

TOP

Chef Base

Drawers	Top Weight Limit (lbs)	Amps	HP	Refrigerant Type / Oz.	Assembled Dimensions (in)	Item Weight (lbs)	Shipping Weight (lbs)
2	771.62 lbs	5.04A	1/6	R290 3.17 oz	32.13" x 60.00" x 25.91"	231.0	290.0

Due to periodic changes in designs, methods, procedures, policies and regulations, the specifications contained in this document are subject to change without notice. While we exercise good faith efforts to provide information that is accurate, we are not responsible for errors or omissions in information provided or conclusions reached as a result of using the specifications. By using the information provided, the user assumes all risks in connection with such use.