

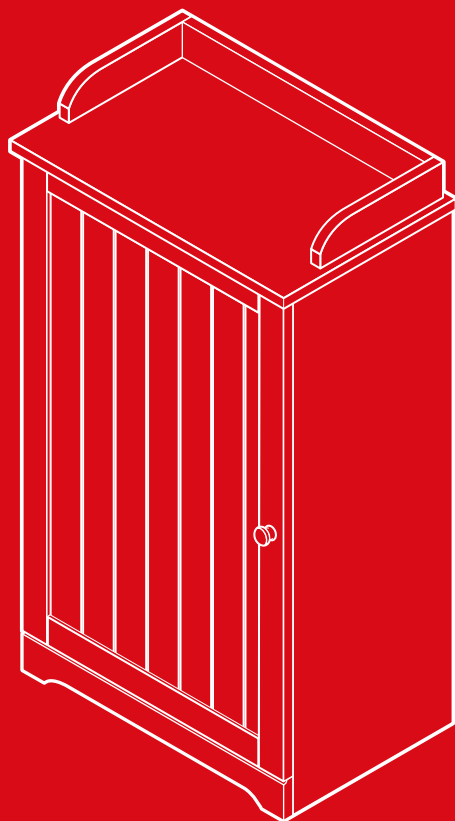

bestchoiceproducts



INSTRUCTION MANUAL

Modern Bathroom
Floor Cabinet



bestchoiceproducts

As shoppers, we're always trying to find the perfect balance between quality & value. At BCP, we believe we've achieved that. Our diverse catalog of everyday essentials is tailored especially to our customers & guaranteed to hit that sweet spot of high quality & low price.

— Always. —

! NOTICE

Please retain these instructions for future reference.

- Please do not exceed the weight limitations of this item.
- Do not stand on or use any part of this item as a step ladder.
- Firmly secure all bolts, screws, and knobs before use.
- Reconfirm that all bolts, screws, and knobs are secure every 90 days.
- Do not use or store this item in the proximity of open flame or flammable/combustible chemicals.
- If any parts are missing, broken, damaged, or worn, stop using this item until repairs are made and/or factory replacement parts are installed.
- Do not use this item in a way inconsistent with the manufacturer's instructions as this could void the product warranty.

TIGHTENING CAMLOCKS

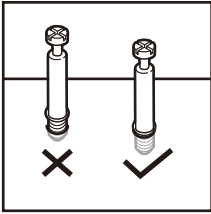

1. Screw cam bolt in completely.

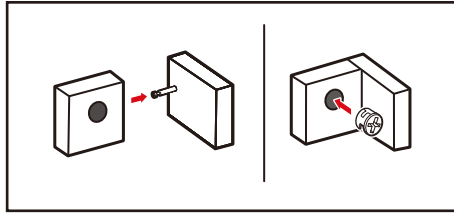

2. Insert cam bolt and cam lock into designated holes.

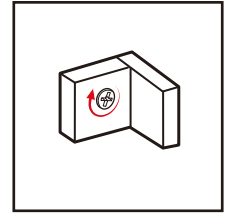

3. Screw cam lock clockwise to secure cam bolt.

TOOLS REQUIRED



PHILLIPS
SCREWDRIVER



1 PERSON
ASSEMBLY



APPROXIMATELY
30 MIN.
ASSEMBLY

HARDWARE

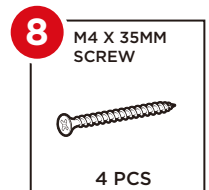
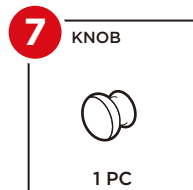
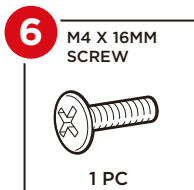
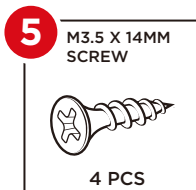
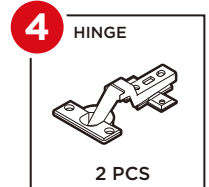
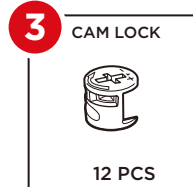
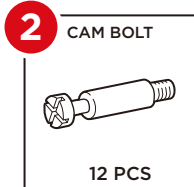
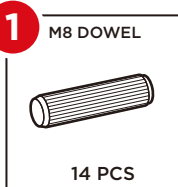

HARDWARE

9 M2.5 X 12MM
SCREW



14 PCS

10 M5 X 11MM
SCREW



4 PCS

11 SHELF PEG



8 PCS

PARTS

A TOP PANEL

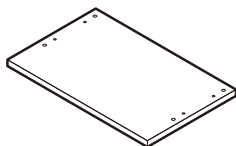

1 PC

B MIDDLE SHELF

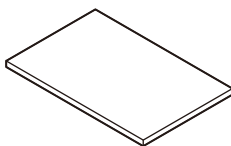

2 PCS

C BOTTOM SHELF

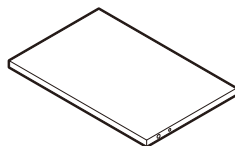

1 PC

D FRONT SKIRT

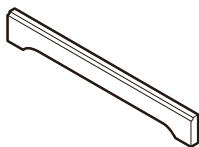

1 PC

E LEFT PANEL

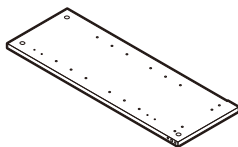

1 PC

F RIGHT PANEL

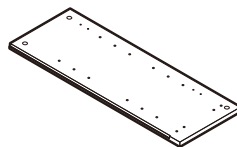

1 PC

G DOOR

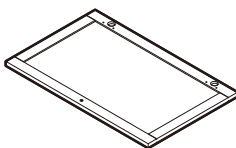

1 PC

H BACK PANEL

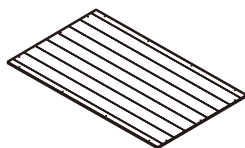

1 PC

I LEFT RAILING

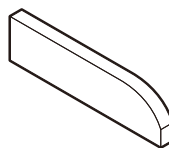

1 PC

PARTS

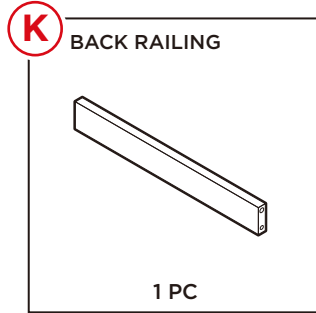
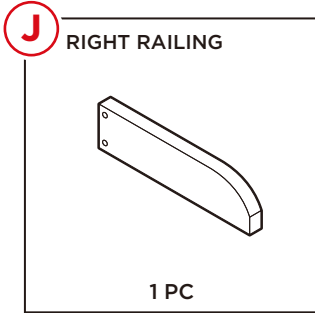

PRODUCT ASSEMBLY

1

Screw eight part 2 cam bolts into the part D front skirt, part E left panel, part F right panel, part I left railing, and part J right railing.

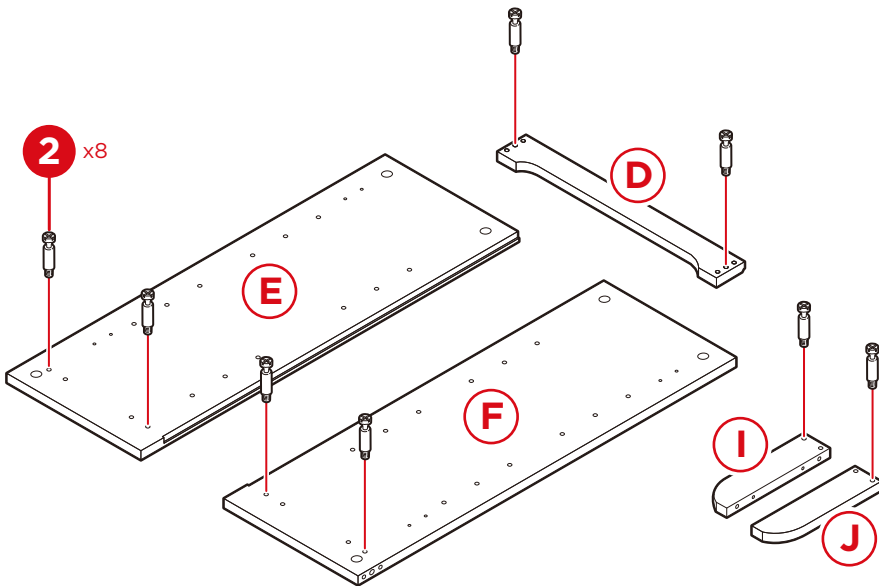

PRODUCT ASSEMBLY

2

Attach part I left railing and part J right railing to part K back railing with two part 1 dowels and two part 3 cam locks.

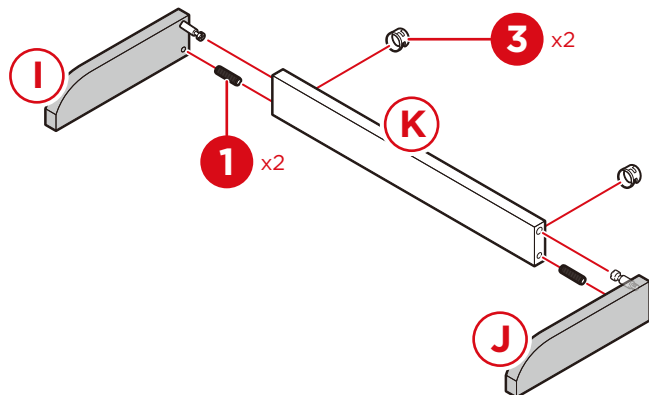

3

Attach two part 4 hinges to the part G door with four part 5 screws.
Attach part 7 knob with a part 6 screw.

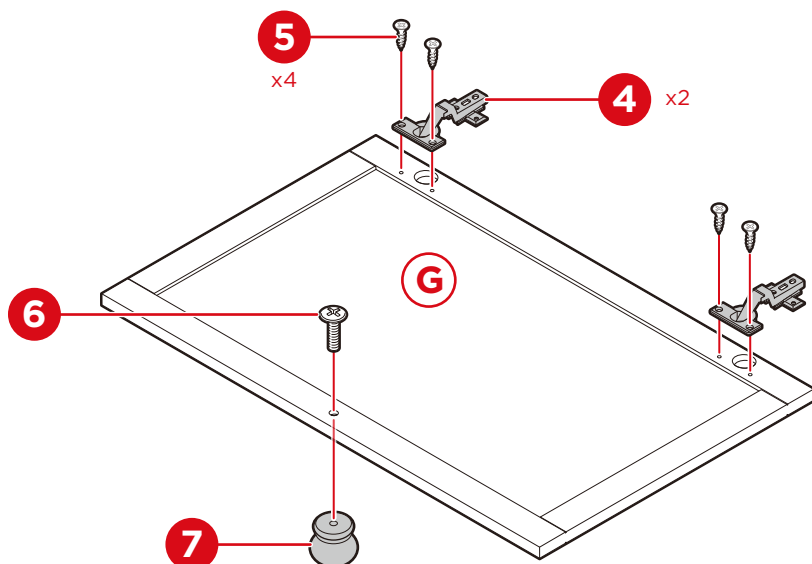

PRODUCT ASSEMBLY

4

Attach the top railings to the part A top panel with four part 1 dowels and four part 8 screws. Screw in four part 2 cam bolts.

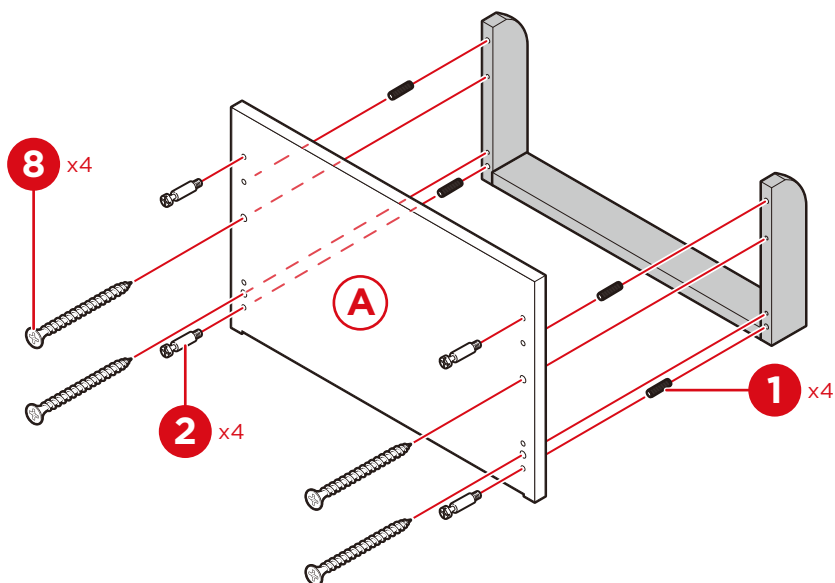

5

Attach part C bottom shelf to part E left panel with two part 1 dowels and two part 3 cam locks.

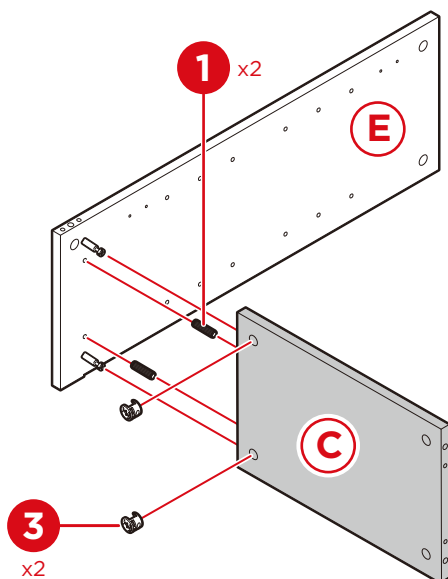

PRODUCT ASSEMBLY

6

Attach part F right panel with two part 1 dowels and two part 3 cam locks.

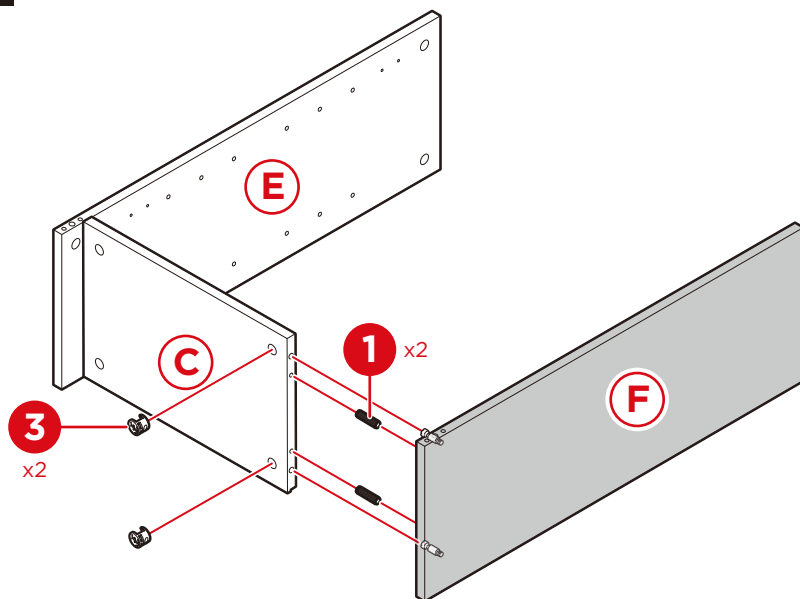

7

Attach part D front skirt with four part 1 dowels and two part 3 cam locks.

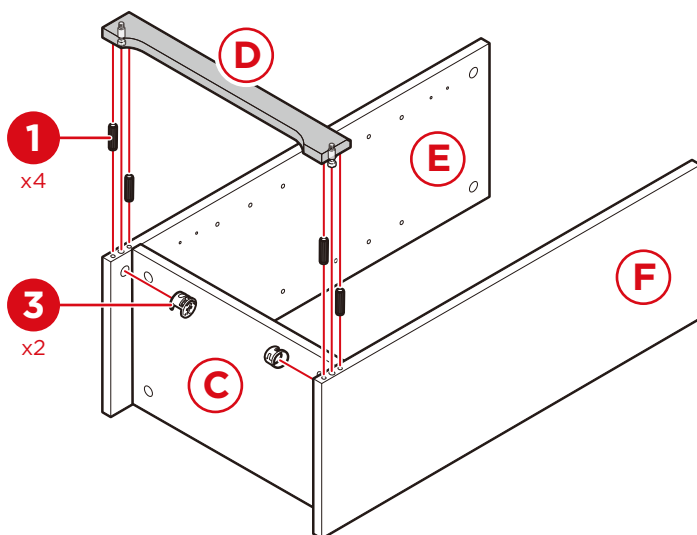

PRODUCT ASSEMBLY

8

Attach the top panel assembly with four part 1 dowels and four part 3 cam locks.

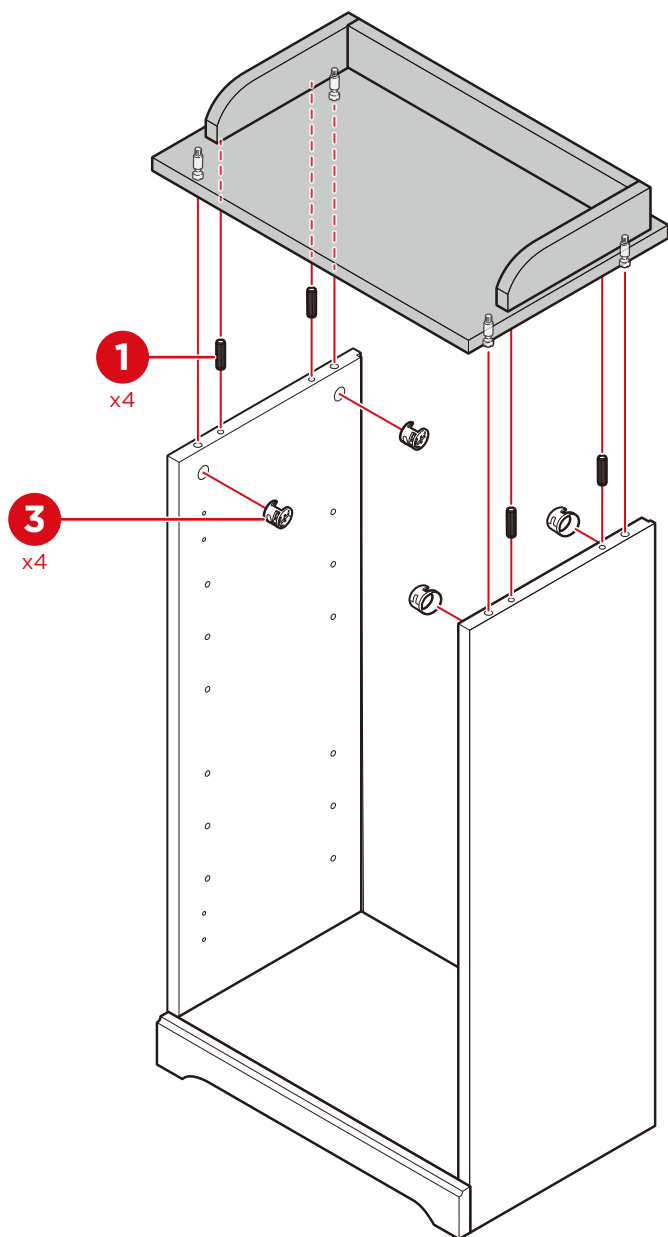

PRODUCT ASSEMBLY

9

Attach the part H back panel with fourteen part 9 screws.

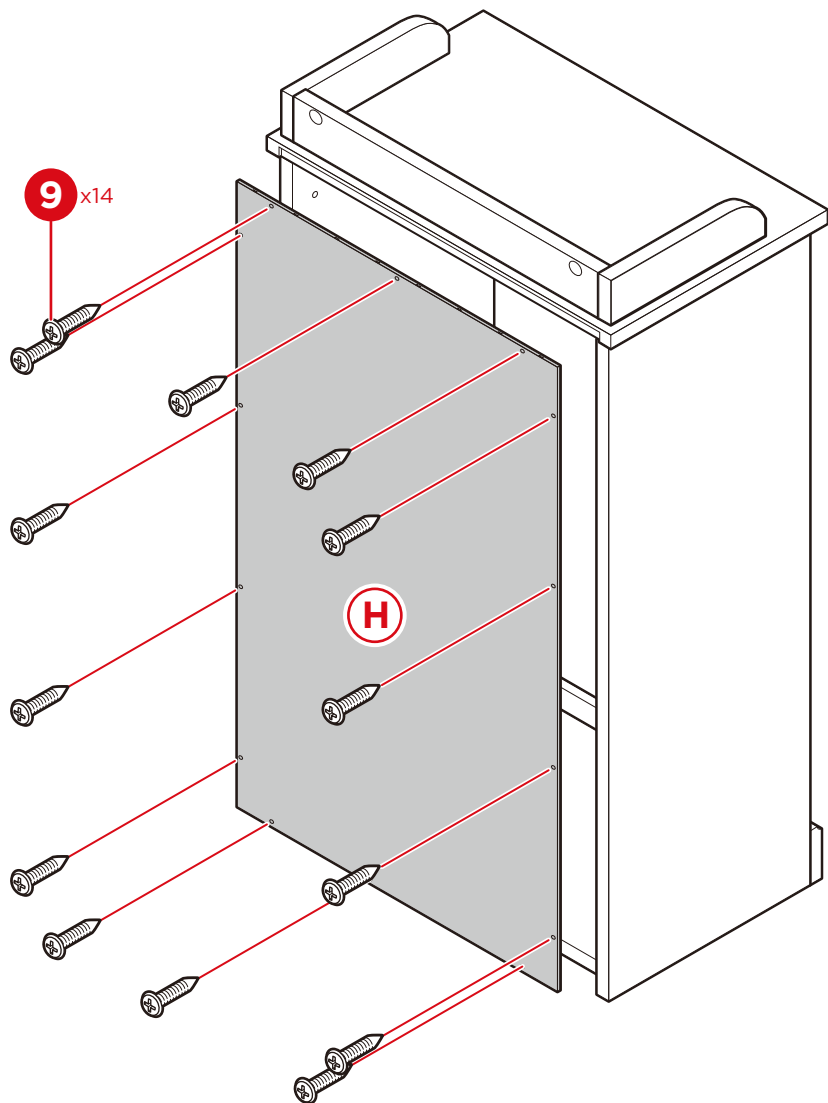

PRODUCT ASSEMBLY

10

Attach the hinges on the part G door with four part 10 screws.

NOTE: Depending on preference, door can be installed on the left or right panel.

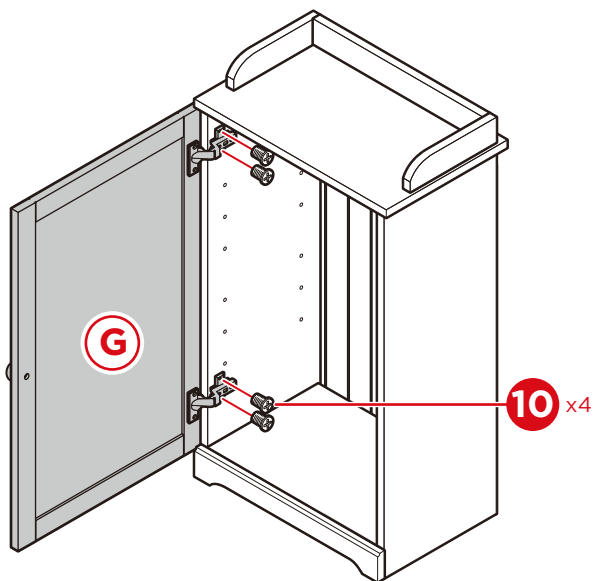

11

Insert eight part 11 shelf pegs. Place two part B middle shelves on the pegs.

NOTE: Insert the shelves at an angle.

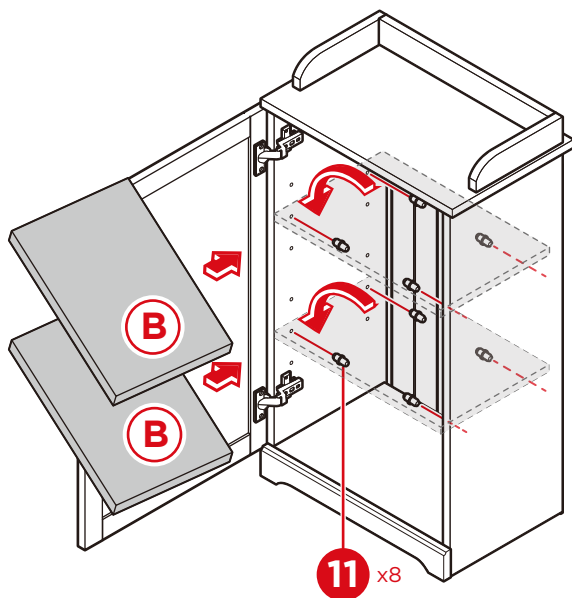



HELP CENTER



Question about your product? We're here to help. Visit us at:

help.bestchoiceproducts.com



Chat Support



Product Inquiry



Orders FAQ



Product Assembly



Returns & Refunds

PRODUCT WARRANTY INFORMATION

All items can be returned for any reason within 60 days of the receipt and will receive a full refund as long as the item is returned in its original product packaging and all accessories from its original shipment are included. All returned items will receive a full refund back to the original payment method. All returned items will not be charged a re-stocking fee.

All returned items require an RA (Return Authorization) number, which can only be provided by a Best Choice Products Customer Service Representative when the return request is submitted. Items received without an RA may not be accepted or may increase your return processing time. Once an item has been received by Best Choice Products, refunds or replacements will be processed within 5 business days.

All returns must be shipped back to the Best Choice Products Return Center at the customer's expense. If the reason for return is a result of an error by Best Choice Products then Best Choice Products will provide a pre-paid shipping label via email. Boxes for return shipping will not be provided by Best Choice Products, and is the customer's responsibility to either use the original shipping boxes or purchase new boxes.

Pictures may be required for some returns to ensure an item is not damaged prior to its return. Items returned are not considered undamaged until they are received by Best Choice Products and verified as such. All damages to items are the customer's responsibility until the item has been received by and acknowledge by Best Choice Products as undamaged.



WARNING

Manufacturer and seller expressly disclaim any and all liability for personal injury, property damage or loss, whether direct, indirect, or incidental, resulting from the incorrect attachment, improper use, inadequate maintenance, or neglect of this product.