











HEKMAN®

A HOWARD MILLER COMPANY

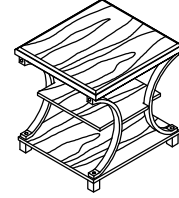
24804 SQUARE LAMP TABLE

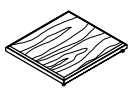
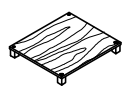
HARDWARE LIST					
A	B	C	D	E	F
ALLEN BOLT M6 X 35 (4 PCS.)	ALLEN BOLT M6 X 80 (4 PCS.)	SCREW M6 X 1/2" (4 PCS.)	FLAT W. M6 8 PCS.	LOCK W. M6 8 PCS.	ALLEN KEY L4 (FOR ALLEN BOLT) 1 PC.
					



PART INSIDE				
1	2	3	4	5
TOP ASSEMBLY (1 Pc)	BASE ASSEMBLY (1 Pc)	SHELF (1 Pc)	METAL LEG (RIGHT) (2 Pcs)	METAL LEG (LEFT) (2 Pcs)
				

STEP 1.

Assembly Instruction

PLACE SQUARE LAMP TABLE IN A SOFT AND FLAT SURFACE. ASSEMBLE THE METAL LEG LEFT (5) TO THE TOP ASSEMBLY (1) USING THE PROVIDED ALLEN BOLT (A), LOCK WASHER (E), FLAT WASHER (D) AND ALLEN KEY (F). ASSEMBLE THE METAL LEG RIGHT (4) TO THE TOP ASSEMBLY (1) USING THE PROVIDED ALLEN BOLT (A), LOCK WASHER (E), FLAT WASHER (D) AND ALLEN KEY (F).

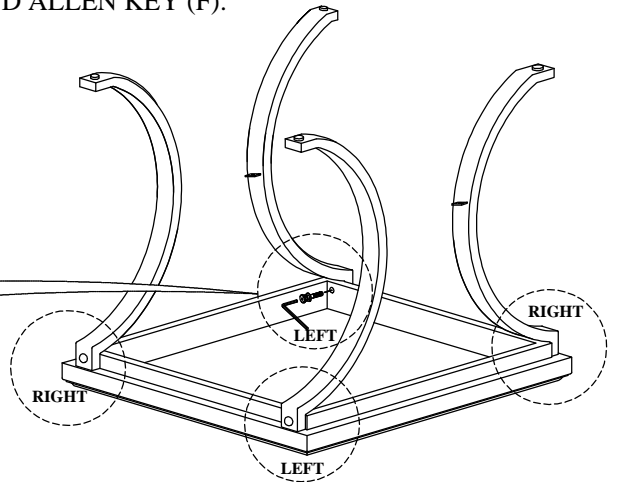
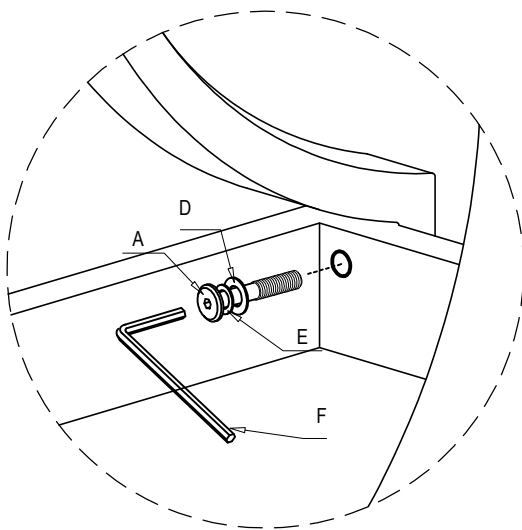

STEP 2.

INSTALL BASE ASSEMBLY (2) TO THE METAL LEGS (4) USING THE PROVIDED ALLEN BOLT (B), LOCK WASHER (E), FLAT WASHER (D) AND ALLEN KEY (F). TIGHTEN ALL.

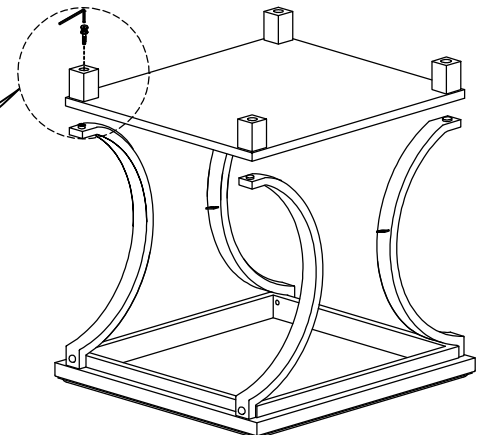
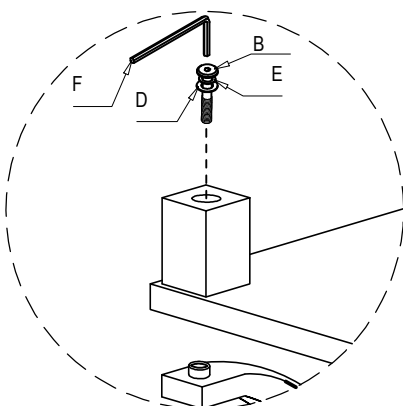

STEP 3.

INSTALL SHELF (3) USING SCREW (C), AND TIGHTEN WITH SCREW DRIVER (NOT INCLUDED)

