

# BLACK DIAMOND®

Project Name: \_\_\_\_\_

Location: \_\_\_\_\_

Item #: \_\_\_\_\_

Qty: \_\_\_\_\_

## Black Diamond Undercounter Refrigerator, 2 Solid Doors, 11.9 Cu. Ft. Capacity, in Stainless Steel

### GRUCRF-48



Delivering exceptional value and performance, the Black Diamond Undercounter Refrigerator is perfect for commercial kitchens, coffee shops, and delis. Built with a durable stainless steel exterior and solid doors, it ensures longevity and efficient operation. With an 11.9 cubic foot capacity, it offers ample ingredient storage. It maintains temperatures between 33° and 40°F with R290 refrigerant, and features a fully automatic controller for easy operation. Cleaning is straightforward with manual defrost and a removable door gasket.

### FEATURES AND CONSTRUCTION

- Capacity of 11.9 Cu. Ft. provides ample storage for ingredients
- Equipped with a 0.25 horsepower compressor for efficient cooling
- Constructed with durable stainless steel for longevity
- Maintains a temperature range of 33° to 40°F for freshness
- Uses environmentally-friendly R290 refrigerant
- Operates on 115V with a NEMA-5-15P plug for convenience
- Features adjustable shelving to accommodate various storage needs
- Features four casters for easy mobility in any setting
- Fully automatic controller for precise temperature management
- Perfect for ingredient storage and kitchen prep needs

### ELECTRIC

115VV / 60Hz / 1Ph

Cord Length (Inches): 98.40"

Plug Type: NEMA 5-15P

Cord set included

NEMA 5-15P



### 3RD PARTY APPROVALS



### WARRANTY (USA / CANADA)

Two (2) Year Limited Warranty on Parts and Labor, Five (5) Year Warranty on Compressor and Evaporator

Contact us for details at 1.877.368.2797



### STORAGE CAPACITY

- Cubic Feet: 11.9 cu. ft.

### TEMPERATURE

- Holding Temperature (Fahrenheit): 33° - 40°

These models are designed to operate in an environment where temperature and humidity do not exceed 75°F (24°C) and 55% relative humidity



# Black Diamond 2 Door Undercounter Refrigerator

GRUCRF-48

FRONT

SIDE

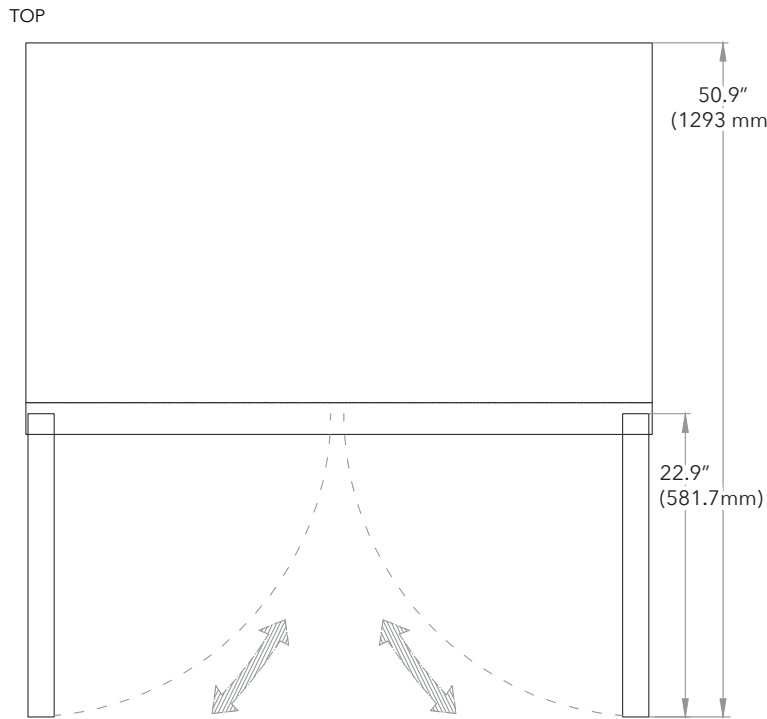
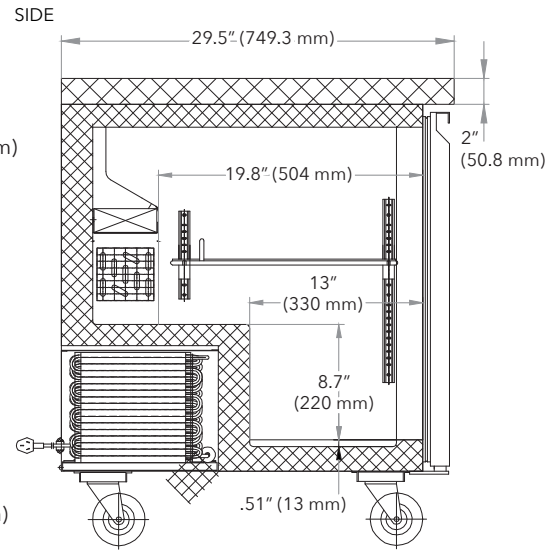
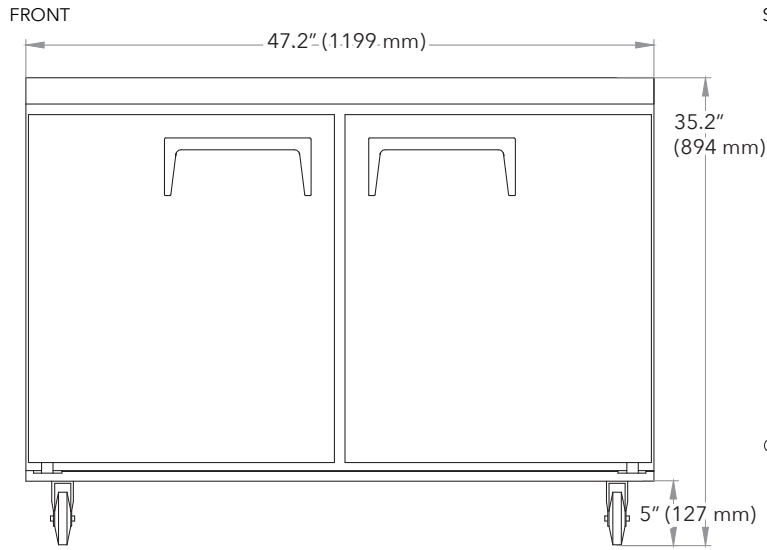

TOP

## Undercounter

Doors	Shelves	Amps	HP	Refrigerant	Assembled Dimensions (in)	Item Weight (lbs)	Shipping Weight (lbs)
2	2	2.4A	1/5	R290	29.50" x 47.20" x 35.20"	213.4	275.0

Due to periodic changes in designs, methods, procedures, policies and regulations, the specifications contained in this document are subject to change without notice. While we exercise good faith efforts to provide information that is accurate, we are not responsible for errors or omissions in information provided or conclusions reached as a result of using the specifications. By using the information provided, the user assumes all risks in connection with such use.