

RENO POOL TABLE

7 Foot Table

Assembly videos
available at
gldproducts.com



Videos para armar
disponible en
gldproducts.com

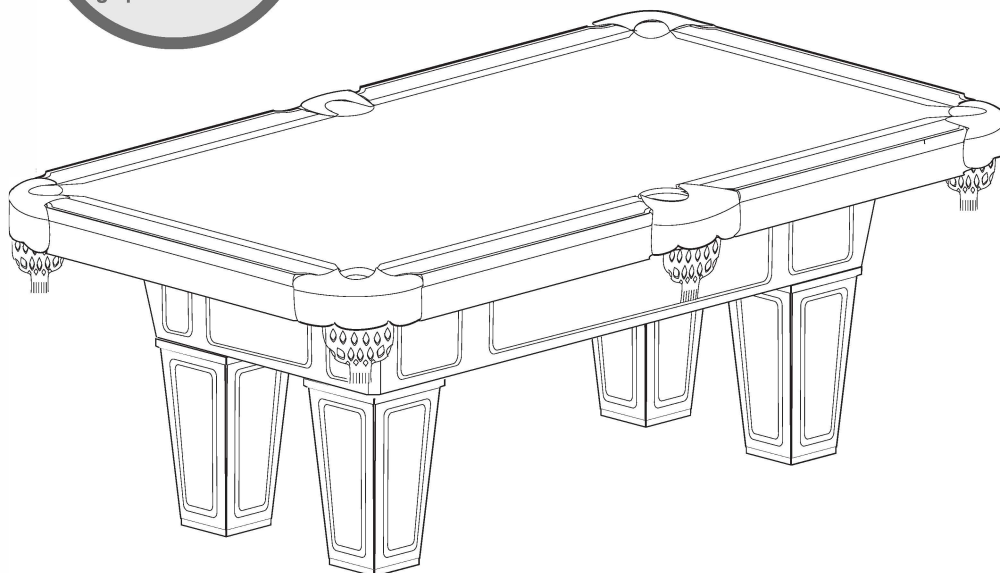

Replacement Parts

Order direct at www.gldproducts.com
or call our Customer Service department at
(800) 225-7593
8 am to 4:30 pm Central Standard Time

Staple your receipt here.

Important: A copy of your receipt will be needed to activate your warranty (see page 17)

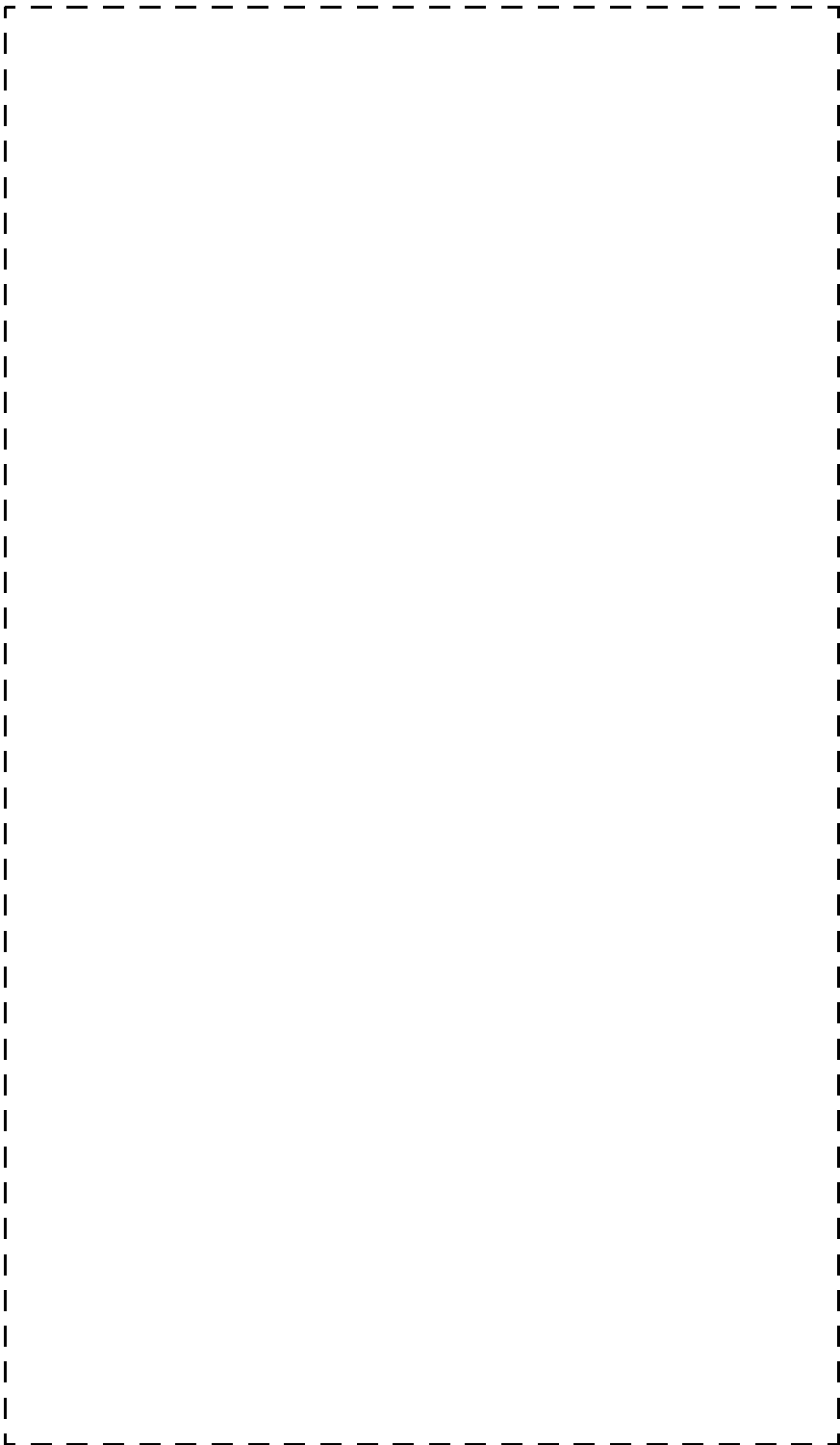



Congratulations and THANK YOU for purchasing the RENO Pool Table. You have chosen a product that should provide years of entertainment. To assist you with customer service and warranty claims, staple your receipt to the inside cover, then keep this manual in a safe place for future reference.









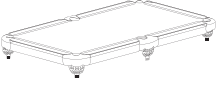
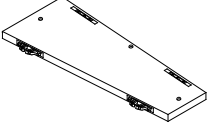
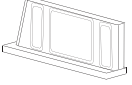
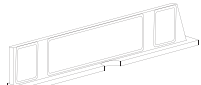
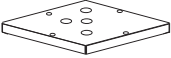

GLD Products

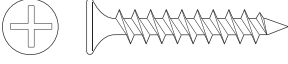

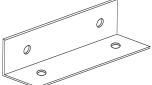
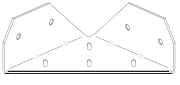
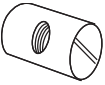
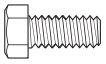
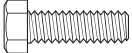
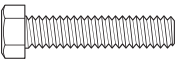
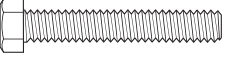



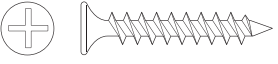
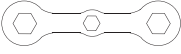

S84 W19093 Enterprise Drive
Muskego, WI 53150 USA
1-800-225-7593
Fax: 1-800-841-6944
Email: support@gldgames.com
Web: www.gldproducts.com

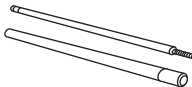
This manual may have been updated. For the latest manual visit the GLD Products website.

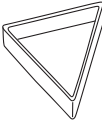
	<p>Place your package near the location where it will be used. Carefully unpack all components and verify you have all the correct pieces.</p> <p>If you notice missing or defective parts, please call us at: 1-800-225-7593</p>
---	--

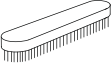
	<p>Please read and understand all instructions before beginning assembly.</p> <p>This assembly will require 2 adults.</p> <p>This product is not for use by children without adult supervision.</p>
---	--

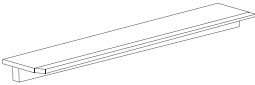
Part No./ Qty	Illustration/ Order Number	Part No./ Qty	Illustration/ Order Number	Part No./ Qty	Illustration/ Order Number
1 Qty. 1	 Table Top Assembly Order No. 1-18	2 Qty. 16	 Table Leg Side Order No. 1-19	3 Qty. 2	 End Cabinet Apron Order No. 1-20
4 Qty. 2	 Side Cabinet Apron Order No. 1-21	5 Qty. 4	 Leg Top Order No. 1-22	6 Qty. 4	 Leg Bottom Order No. 1-23
7 Qty. 32	 Insert Order No. 1-24	8 Qty. 32	 1-3/4" Phillips Head Screw Order No. 1-253	9 Qty. 16	 Wood Dowel Order No. 2-61
10 Qty. 2	 Support Beam Order No. 1-5	11 Qty. 4	 Angle Bracket Order No. 1-6	12 Qty. 4	 Leg Mounting Bracket Order No. 1-7
13 Qty. 4	 5/16-18 Barrel Nut Order No. 1-8	14 Qty. 32	 5/16-18 x 5/8" Hex Head Bolt ^a Order No. 1-254	15 Qty. 16	 5/16-18 x 1" Hex Head Bolt ^a Order No. 1-255
16 Qty. 12	 5/16-18 x 2" Hex Head Bolt ^a Order No. 1-11	17 Qty. 4	 5/16-18 x 5 1/2" Hex Head Bolt ^a Order No. 1-12	18 Qty. 4	 5/16 x 15 mm Flat Washer Order No. 1-13
19 Qty. 48	 5/16 x 23 mm Flat Washer Order No. 1-14	20 Qty. 12	 5/16 x 32 mm Flat Washer Order No. 1-15	21 Qty. 4	 Leveler Order No. 2-26
22 Qty. 8	 1-1/2" Phillips Head Screw Order No. 2-118	23 Qty. 1	 Wrench Order No. 1-17	24 Qty. 1	 Allen Wrench 5/32" Hexagonal Order No. 2-32

<p>25</p>  <p>Qty. 2</p> <p>57" Billiard Cue Order No. 2-23</p>	<p>26</p>  <p>Qty. 2</p> <p>Chalk Order No. 2-24</p>	<p>27</p>  <p>Qty. 1</p> <p>Triangle Order No. 2-27</p>
<p>28</p>  <p>Qty. 1</p> <p>Billiard Balls Order No. 2-21</p>	<p>29</p>  <p>Qty. 1</p> <p>Brush Order No. 2-22</p>	<p>30</p>  <p>Qty. 2</p> <p>Preassembled Rail/Apron - Foot Right or Head Left Order No. 1-207</p>
<p>31</p>  <p>Qty. 2</p> <p>Preassembled Rail/Apron - Foot Left or Head Right Order No. 1-20</p>	<p>32</p>  <p>Qty. 2</p> <p>Preassembled Rail/Apron - End Rail Order No. 1-206</p>	

a. If replacement bolts are needed a 7/16" Hex Head Bolt can be used.
Common fasteners are available at your local hardware store.

IF YOU HAVE A WARRANTY CLAIM, CALL US FIRST:

Please refer to page 17.

GLD Products

Available 8 am to 4:30 pm Central Standard Time

S84 W19093 Enterprise Drive
Muskego, WI 53150 USA
1-800-225-7593
Fax: 1-800-841-6944

Email: support@gldgames.com
Web: www.gldproducts.com

For all claims, please have your receipt and item number when you call. The product item number can be found on the front cover.

If you are instructed to return the product for service, you are responsible for shipping the unit at your expense.

PRODUCT REGISTRATION

Important: The product registration form on page 19 and a copy of your receipt must be completed and returned within 10 days of purchase to validate your warranty.

Preparing for Assembly

- Be sure to unpack all of the parts included in this package. Some parts may be in obscure locations of the packaging. Check inside any tubes or sleeves. Save all packing material until the product is fully assembled and functional.
- Compare the parts in your package with the Parts Identifier description on page 5.
- After unpacking large products, some disassembly may be required prior to beginning the assembly.

Tools Required

- Wrench (#23) - included with table
- 5/32" Allen wrench (#24) - included with table
- Phillips screwdriver (not included)
- Flat head screwdriver (not included)
- Level (not included)
- Electric screwdriver may be helpful. **CAUTION:** You must set at LOW TORQUE and use extreme caution because you could overtighten the hardware, strip the screws, or damage the table.
- 12 mm Hex socket or wrench (not included)

Assembly Tips

Make sure you understand the following before you begin to assemble your game table.

1. READ THIS MANUAL all the way through before beginning assembly.
2. When installing parts that have more than one bolt, start ALL bolts in that part by hand before tightening anything.
3. Some drawings or images in this manual may not look exactly like your product.
4. You will need a second adult to assist with this assembly.

Note: Save all packing materials until the parts have been inspected and the table is assembled.

Unpack the Pieces

- Lay the box on a flat surface (floor). You may want this near your area of assembly.
- Several boxes should be visible and strapped to the underside of the table top.
- The table top should be at the bottom.
- The straps should be removed and the boxes opened. Some table designs require that the legs be shipped separately.
- Unpack the boxes and part bags. Inspect and count the parts. The Parts Identifier page can be used to record your results.
- If any parts are damaged or missing contact GLD customer service.
- Missing fasteners may be purchased at a hardware store using the descriptions on the Parts Identifier page(s).

STEP 1 - ASSEMBLE THE APRONS

1. Place the four apron side pieces (#3 and #4) in position. They should be upside down.
2. Use an angle bracket (#11) in each corner. Finger start four bolts (#14) with washers (#19) through the angle bracket and into two of the apron pieces.
3. Repeat in all four corners.
4. Tighten all the bolts (wrench #23). When tightening the bolts, be certain the two pieces are properly lined up at the corners.

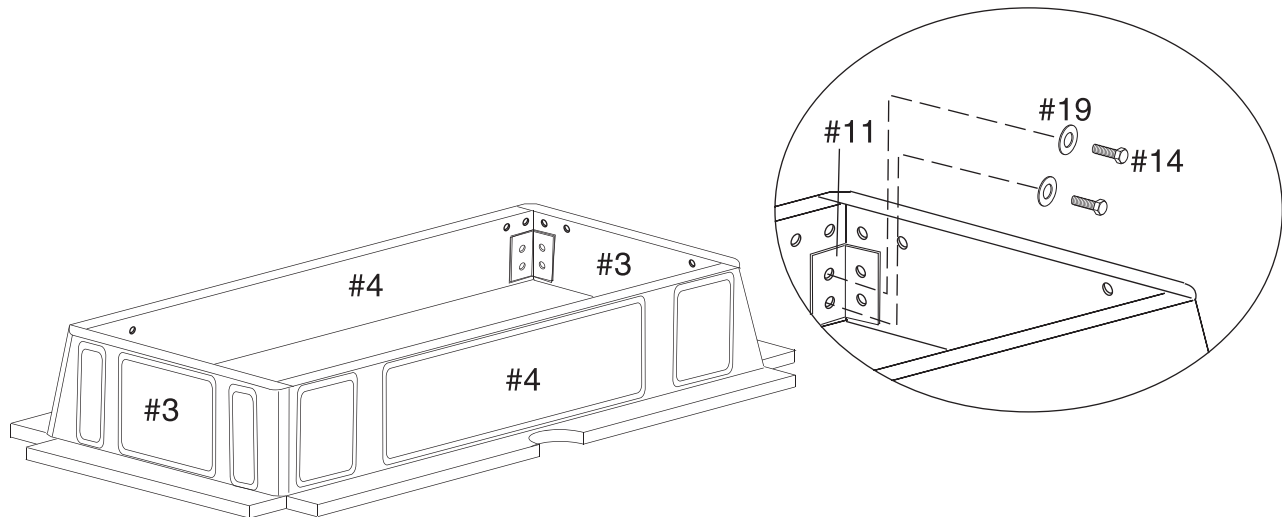
**STEP 2 - ASSEMBLE LEG BRACKET**

1. Install one leg mounting bracket (#12) in each corner. Use four bolts (#14) with washers (#19). Finger start all the bolts. Note that the flat part of the bracket will be up and even with the side aprons.
2. Hold the bracket in position and tighten all the bolts (wrench #23).

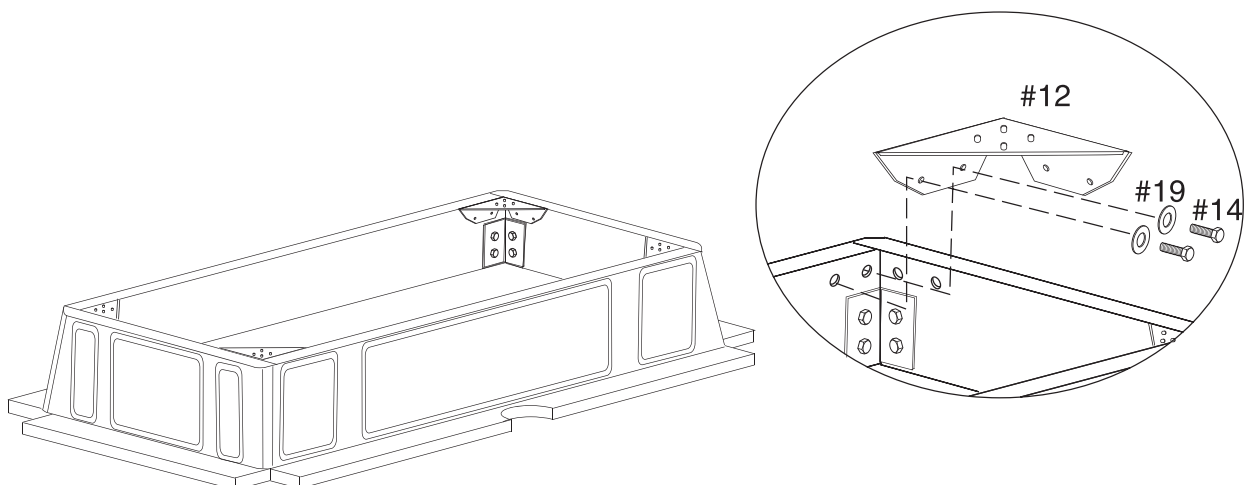

STEP 3 - ASSEMBLE THE LEGS

All of the leg sides are the same and can be assembled interchangeably.

1. Install the Insert (#7) and Wood Dowel (#9) into Table Leg side (#2), please refer to the diagram A below.
2. Start connecting each table leg side (#2) to create the full leg, please refer to diagram B & C below. Install bottom (#6) on the base of each leg by using four Screws (#8). Please refer to below diagram D.
3. Repeat steps 1 and 2 for the remaining Table Leg Sides (#2), once completed you will have 4 assembled legs.
4. Begin installing Leg Top (#5) on the top of each assembled leg. See Diagram D below. Once completed you will start installing each leg to the table base.

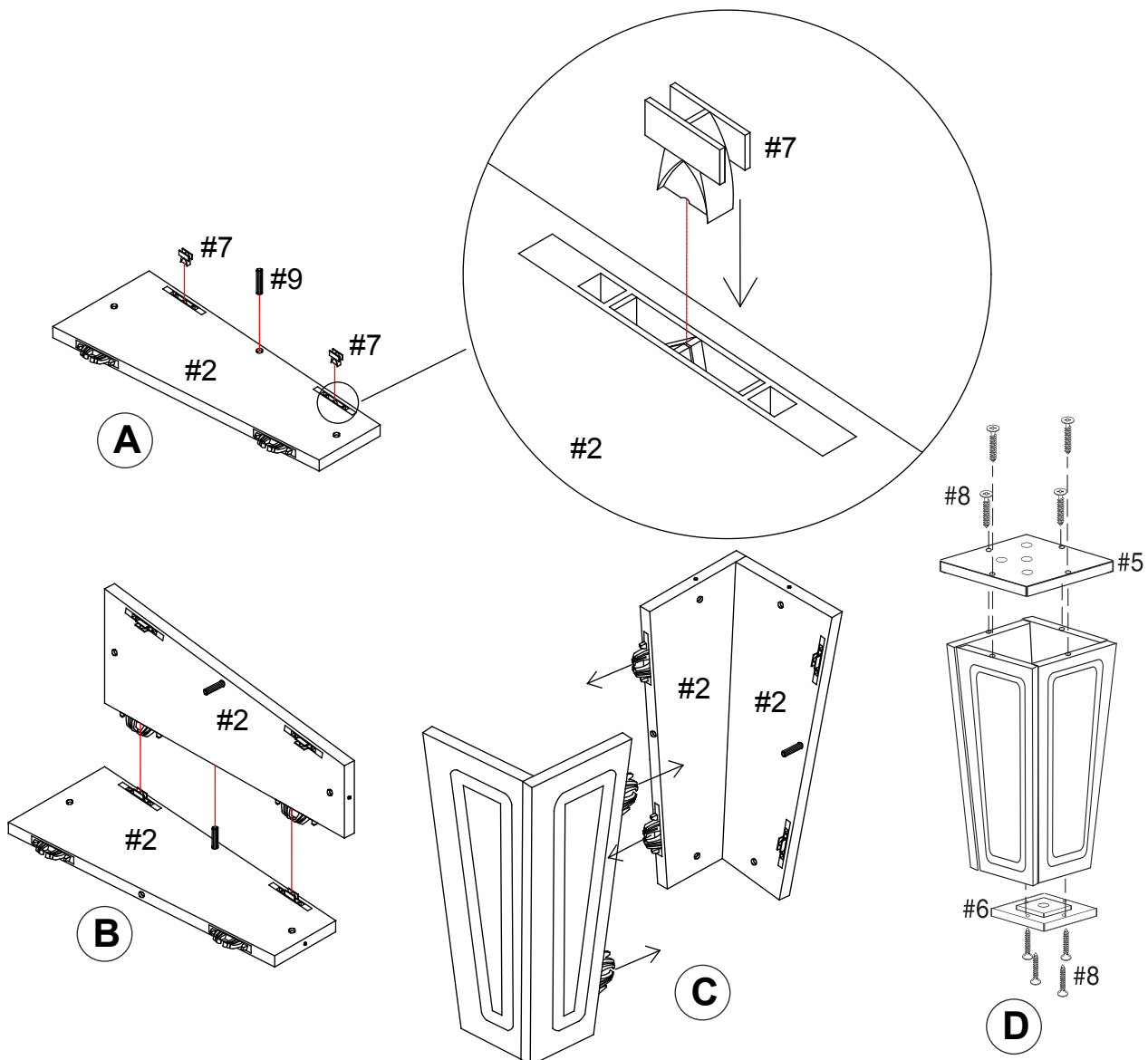

STEP 4 - ATTACH THE LEGS

1. Each leg is held in place by four bolts (#15) with washers (#19).
2. Position the leg on top of the bracket. Insert a bolt with washer through the bracket and into the leg.
3. Start each of the four bolts by hand, then hold the leg in its final position.
4. Tighten the bolts using the wrench (#23). Repeat for the other 3 legs.
5. Screw the leveler (#21) half-way into the bottom of each leg.

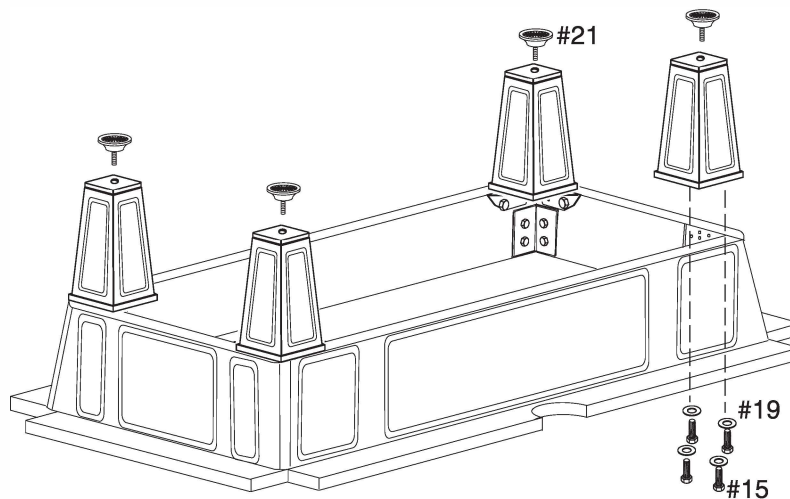

STEP 5 - TURN BASE OVER

The base assembly is ready to be turned over.

USE AT LEAST TWO PEOPLE TO LIFT THE BASE ASSEMBLY AND TURN IT OVER TO REST ON THE LEGS.

DO NOT ROLL THE TABLE OVER. This will place a sideways force on the legs. The legs should be off the floor until the base assembly is rotated completely. Set the base assembly down.

If the leg positions need adjusting, loosen the bolts, adjust, and re-tighten.

DO THIS

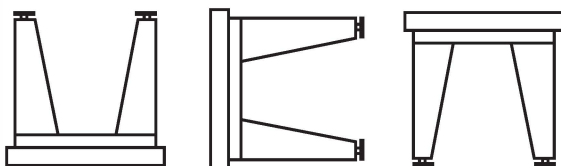

NOT THIS

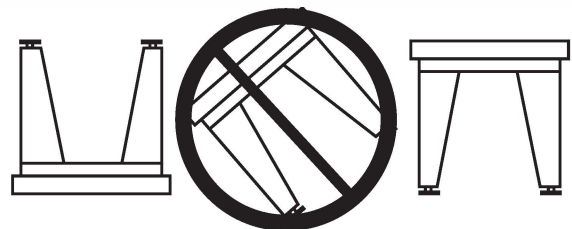

STEP 6 - INSTALL SUPPORT BEAMS

1. The table base is now right-side up. To install the two support beams (#10), position the support beams on the base assembly in the appropriate slots.
2. Insert a bolt (#17) with a washer (#18) through the side support.
3. Insert a barrel nut (#13) into the hole at the end of the beam, making sure the slot is visible and the slot lines up with the bolt. Thread the bolt into the barrel nut. If the barrel nut drops too far into the hole in the support beam, the threads will not engage. If this happens, use a magnet or turn the support beam over to remove the barrel nut. Thread the bolt into the barrel nut.
4. When the bolt is in place the nut can be pushed down to line up with the bolt. Thread the bolt into the barrel nut.
5. Hold the support beam in place by screwing in the side support bolt until snug, not tight.
6. Insert two screws (#22) in the ends of the support beams and tighten with a Phillips screwdriver.
7. Tighten the bolts using a 12 mm socket wrench.

NOTE: The support beams should not rise up above the surrounding frame. If this happens loosen the bolt until the support drops. The bolt can be tightened after the top is on and secure.

8. The base can now be leveled.

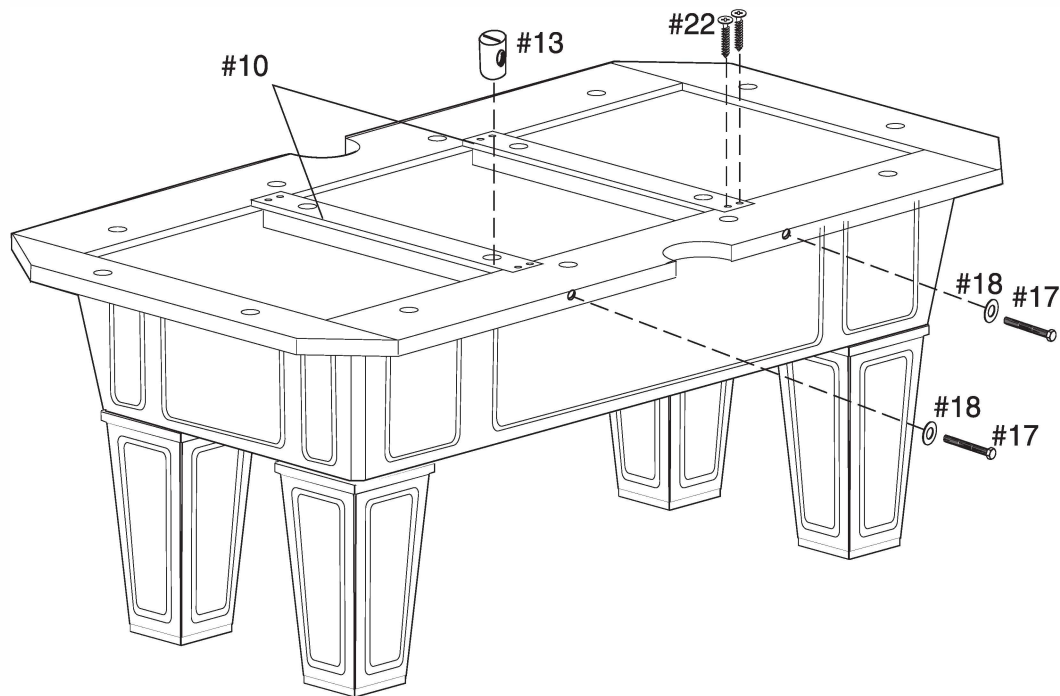

STEP 7 - LEVEL THE TABLE BASE

Do not drag the table to a new position. Lift and carry it. Do not lift using the pockets.

1. Put the base where you will be using the table.
2. Use a carpenters level to find the low side.
3. Lift the table leg off the floor and unscrew the leveler in the bottom of the leg a small amount.
4. Repeat until the base is level. Be sure to check level at both ends side to side as well as the longer length.

STEP 8 - ATTACH THE TABLE TOP

1. Inspect the underside surface of the table top (#1). When the table is shipped there are several wooden shipping blocks screwed to the bottom. These must be removed. The area of the table top that rests on the side supports must be free of raised material around screw holes.

NOTE: Be certain the two support beams (#10) are screwed down, not over-tightened and will not push up on the table top.

2. Using at least two people, lower the table top (#1) onto the base.
3. Line up one or two of the holes in the top with the holes in one end of the base assembly.
4. Finger start a bolt (#16) with a washer (#20) into the hole(s).
5. Line up the remaining holes and finger start a bolt with a washer in each.
6. Check the position of the table top.

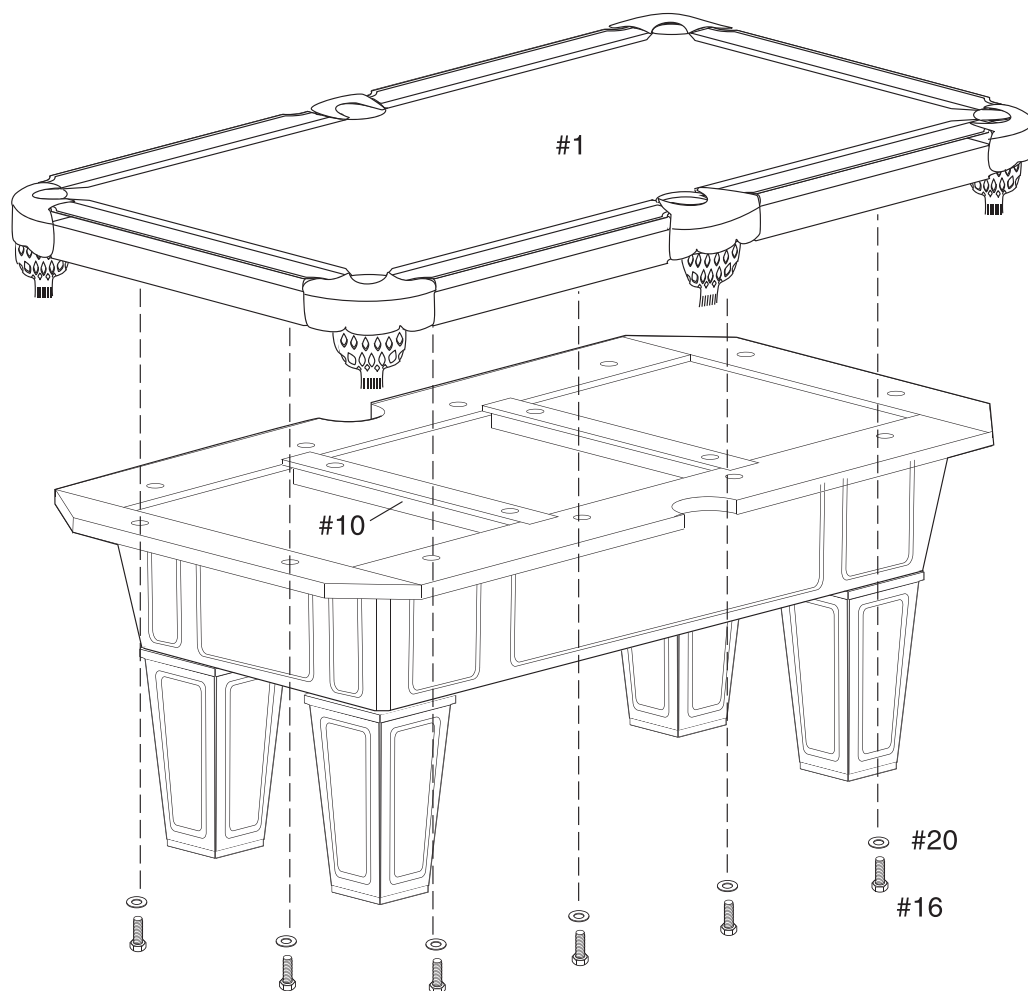

STEP 9 - SECURING AND LEVELING THE TABLE TOP

Once in position, make sure the table top is flat before screwing it down.

1. Be certain the table base is in its final position and level.
2. Start each screw without making them too tight. If the table is still level, tighten each screw.

CAUTION: If using a power tool to tighten the bolts, be certain it is on a low torque setting.

4. Using the proper wrench, lightly tighten each bolt without crushing the underside supports.
5. When the bolts are secure, test for level. Roll one of the pool balls slowly over the playing surface. If the ball rolls on a straight path, the table is level. If the path curves, the table needs to be leveled (see Step 7).
6. If the two support beams need to be tightened do it now. Tighten the four bolts until snug. Over-tightening may lift the table top upward.

THE TABLE IS ASSEMBLED. IF IT IS NOT ALREADY IN POSITION FOR PLAY, IT CAN BE MOVED.

DO NOT SLIDE OR DRAG. Use at least two adults to lift into position, then re-level.

Care and Use of your Table

- This product is intended for INDOOR use only.
- DO NOT sit, climb, or lean on the table.
- DO NOT drag the table when moving it. This will damage the legs.
- Keep your table covered. The playing surface can be brushed or lightly vacuumed with low suction.
- DO NOT lift the table by placing your hands under the pockets, and do not sit, lean or put pressure on the pockets.
- The cloth playing surface can rip or tear. Keep sharp objects off the playing surface.
- Some “trick shots” may tear or dimple the cloth surface.
- To clean the hard surfaces spray a cloth with a mild cleaner and wipe.

TROUBLESHOOTING

Problem: Pool balls change direction and roll toward one of the pockets.

Cause: The corner of the table top is low.

Solution: Loosen the bolts that hold the table top to the supports. Place shims (.010 inch thick) on each side of the corner pocket. Tighten the bolts and roll pool balls to test.



Problem: Pool balls roll to edges.

Cause: The playing surface is high in the center.

Solution: Loosen the bolts that hold the table top to the supports. Add shims (.010 inch thick) along the two side supports. Tighten the bolts on the two short ends first. Then lightly tighten the bolts along the edges. Roll pool balls to test.



90-DAY LIMITED WARRANTY

The Manufacturer warrants to the original retail purchaser that this product is free from defects in material and workmanship under normal use and conditions for a period of ninety (90) days from the date of original purchase. Further, the Manufacturer warrants to the original retail purchaser that the Accuslate playing surface of your game table will remain flat, within a tolerance of +/- 30/1000 of an inch, measuring from any flat plane within the Accu Slate playing surface for a period of seven (7) years from the date of original purchase. The Manufacturer's liability is limited to the repair or replacement, at its option, of any defective product and shall not include any liability for indirect, incidental or consequential damages of any kind.

Should this product become defective due to material or workmanship within the warranty period, contact our Customer Service Department. This warranty is not transferable and does not cover normal wear and tear or damage caused by improper usage, negligence, misuse, abuse, transportation damage, acts of nature, or accident (including failure to follow the instructions in this manual). It does not cover expendable items such as batteries, light bulbs, fuses, accessories, cosmetic parts and other items that wear out due to normal usage, including felt covered areas of the playing surface. This warranty is also void if the product is disassembled and reassembled, damaged, modified from its original state, or used for other than indoor personal residential use (no commercial or rental applications). This warranty gives you specific legal rights, and you may have other rights which vary from state to state.

IF YOU HAVE A WARRANTY CLAIM, CALL US FIRST (8 - 4:30 CST):

Please have your receipt and item number (found on the front cover) when you call.

GLD Products

S84 W19093 Enterprise Drive

Muskego, WI 53150 USA

1-800-225-7593

Fax: 1-800-841-6944

Email: support@gldgames.com

Web: www.gldproducts.com

If you are instructed to return the product for service, you are responsible for shipping the unit at your expense to the above address in packaging that will protect against further damage. All warranty or repair requests require a Return Authorization Number prior to returning the item.

PRODUCT REGISTRATION

Important: The product registration form on page 19 must be completed and returned along with a copy of your receipt within 10 days of purchase to validate your warranty.

On-line registration is also available.

Go to <http://www.gldproducts.com/index.php/registration> or click on this link. Follow the on-line instructions.

This page intentionally left blank.

REGISTER YOUR PRODUCT

Place postage here

Complete this form, include a copy of your receipt, fold, tape (do not staple) and return within 10 days of purchase. This protects your warranty and will help us develop new products!

Cut here.

GLD Products
Warranty Department
S84 W19093 Enterprise Drive
Muskego, WI 53150 USA

Fold here second.



www.gldproducts.com

GAME TABLES	HOME CASINO
GAMES AND ACCESSORIES	BILLIARD CUES
BILLIARD ACCESSORIES	DARTBOARDS
SOFT-TIP DARTS	STEEL-TIP DARTS
FLIGHTS AND SHAFTS	DART CASES AND ACCESSORIES

Fold here first.

Name	Date of Purchase
Address	Phone-Day
City	Phone-Evening
State Zip	Email
Purchase Price:	Item: 64-0126 RENO 7' Pool Table
Store Name:	

Remember to attach a copy of your receipt.

This page intentionally left blank.

RENO II 7.5' Pool Table

Item 64-0126 Rev C

REPLACEMENT PARTS

Order direct at www.gldproducts.com
Or call our Customer Service department at
(800) 255-7593
8:00 AM to 4:30 PM Central Standard Time

Order No.	Description
1-18	Table Top Assembly
1-19	Table Leg - 1 side
1-20	End Cabinet Apron
1-21	Side Cabinet Apron
1-5	Support Beam
1-6	Angle Bracket
1-7	Leg Mounting Bracket
1-8	5/16-18 Barrel Nut
1-254	5/16-18 x 5/8" Hex Head Bolt
1-255	5/16-18 x 1" Hex Head Bolt
1-11	5/16-18 x 2" Hex Head Bolt
1-12	5/16-18 x 5-1/2" Hex Head Bolt
1-13	5/16 x 15 mm Flat Washer
1-14	5/16 x 23 mm Flat Washer
1-15	5/16 x 32 mm Flat Washer
2-32	Allen Wrench
1-17	Wrench
1-22	Leg Top
1-23	Leg Bottom
1-24	1/4 x 1-1/8 Socket Head Allen Bolt
1-253	1-3/4" Phillips Head Screw
2-61	1/4" x 15 mm Flat Washer
2-26	Leg Levelers
2-118	1-1/2" Phillips Head Screw
2-21	Billiard Balls
2-22	Brush
2-23	Cue Stick
2-24	Chalk (1 package)
2-27	Triangle
1-207	Preassembled Rail/Apron - Foot Right or Head Left
1-208	Preassembled Rail/Apron - Foot Left or Head Right
1-206	Preassembled Rail/Apron - End Rail

This page intentionally left blank.



www.gldproducts.com

GAME TABLES

HOME CASINO

GAMES AND ACCESSORIES

BILLIARD CUES

BILLIARD ACCESSORIES

DARTBOARDS

SOFT-TIP DARTS

STEEL-TIP DARTS

FLIGHTS AND SHAFTS

DART CASES AND ACCESSORIES

GLD[®]

P R O D U C T S

PROUD MANUFACTURER OF

Viper[®]
by GLD PRODUCTS

Fat Cat[®]
by GLD PRODUCTS

MAINSTREET[®]
Classics
by GLD PRODUCTS

CASEMASTER[®]

S84 W19093 Enterprise Drive • Muskego, WI 53150 USA
262.679.8730 or 1.800.225.7593 tele
262.679.8738 or 1.800.841.6944 fax
Email: support@gldgames.com
www.gldproducts.com