

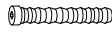

ASSEMBLY INSTRUCTION FOR 24907 CHAIR SIDE TABLE

HARDWARE LIST

| NO. | ITEM | DESCRIPTIN | QTY. |
|-----|---|----------------------|------|
| 1 |  | JCB Bolt M6 X 20MM | 12 |
| 2 |  | Flat washer M8X25 MM | 12 |
| 3 |  | Allen wrench | 1 |

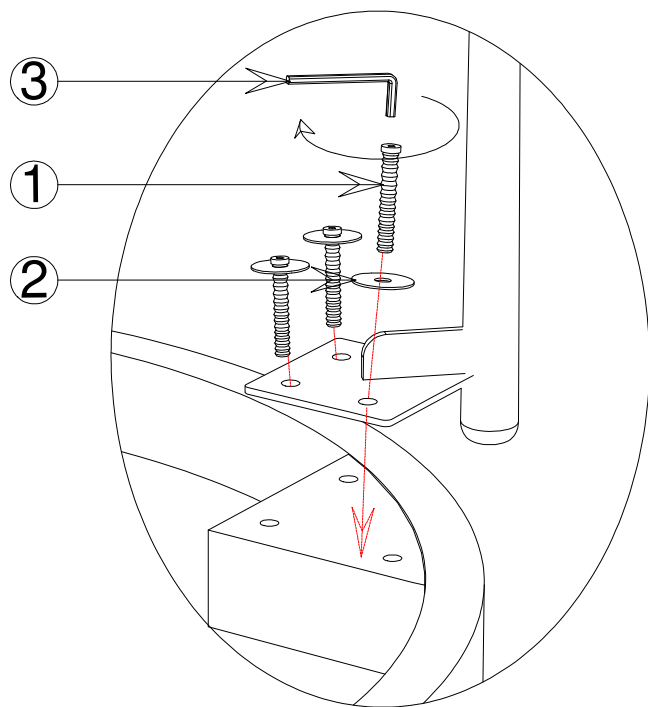
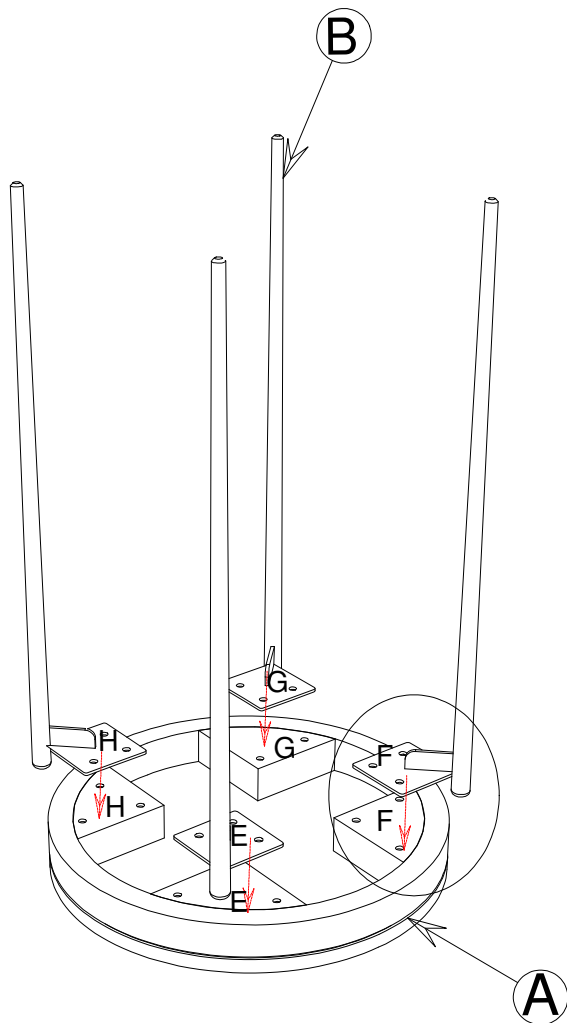
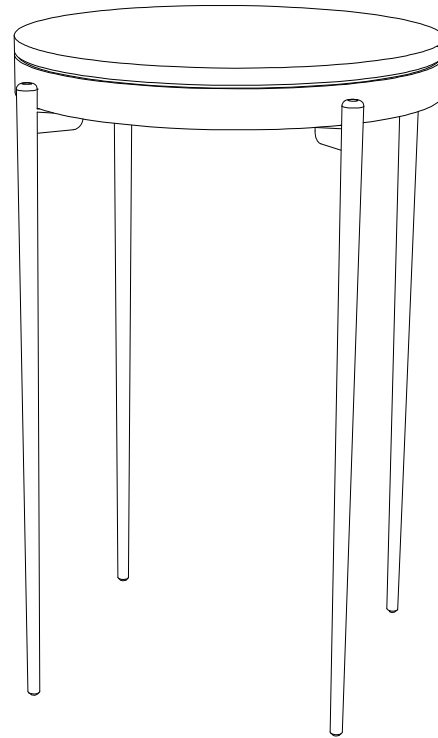

TO ASSEMBLY :

- STEP 1 : Unpack chair side table and turn the top (A) upside down on a clean, soft surface.
- STEP 2 : Match the iron legs (B). use matching marks E F G H - on top (A)
- STEP 3 : Align holes in legs (B) with holes on bottom of top (A) and slide it into position.
- STEP 4 : Thread the flat washer(2) , JCB bolt (1) to leg (B) . Do not tighten end assemblies fully.
- STEP 5 : Tighten bolts in step 3 fully with allen wrench (3) then carefully turn the table upright.