

Z125 8" [203 mm] DIAMETER ROOF DRAIN Low Silhouette Dome

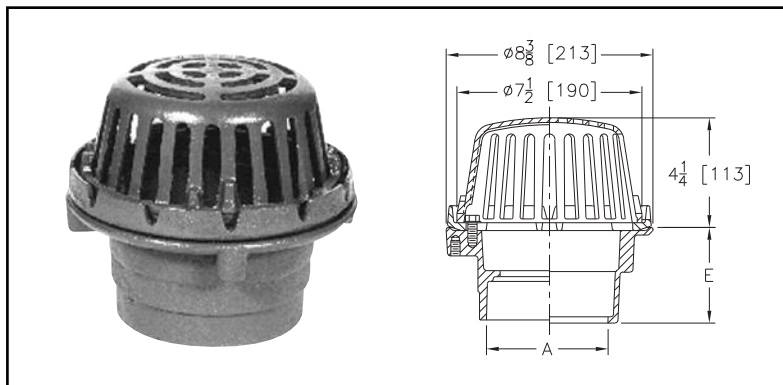

A Pipe Size Inches [mm]	Approx. Wt. Lbs. [Kg]	Dome Open Area Sq. In. [cm ²]
2 - 3 - 4 [51-76-102]	14 [6]	43 [277]

ENGINEERING SPECIFICATION: ZURN Z125 8" [203 mm] diameter roof drain, Dura-Coated cast iron body with combination flashing clamp/gravel guard and low silhouette cast iron dome.

OPTIONS

OUTLETS (Specify pipe size in inches and type of outlet.)

OUTLET TYPE	OUTLET DESIGNATION Pipe Size/Outlet Type	'E' BODY HT. DIM. In./[mm]
Inside Caulk	21C, 31C, 41C	3-7/8" [98 mm]
Threaded	21P, 31P, 41P	2-5/8" [67 mm]
No-Hub	2NH, 3NH, 4NH	3-7/8" [98 mm]
Neo-Loc	2NL, 3NL, 4NL	3-3/4" [95 mm]

PREFIXES

Z	D.C.C.I. Body with Dome*
ZA	D.C.C.I. Body with Aluminum Dome
ZRB	D.C.C.I. Body with Plain Bronze Dome

SUFFIXES

- AR Acid Resistant Epoxy Coated Finish
- BS Bronze Mesh Screen Over Dome
- C Underdeck Clamp
- DP Top-Set® Roof Deck Plate (Replaces both the -C and -R)
- DR Adjustable Drain Riser Extension Assembly
Adjustment from 3-5/8" [92 mm] to 7-1/4" [184 mm]
- E 2" [51 mm] High Static Extension (Specify Height)
- ES Static Extension with Secondary Clamp Collar at Body
(For clamping at roof drain body.)
- G Galvanized Cast Iron
- R Roof Sump Receiver
- SC Secondary Clamp Collar
- SS Stainless Mesh Screen Over Dome
- TC Neo-Loc Test Cap Gasket (2" [51 mm] to 4" [102 mm] NL Bottom Outlet Only)
- VP Vandal-Proof Secured Top
- XJ Vertical Expansion Joint (See Z190)
- 84 Stainless Steel Perforated Gravel Guard
- 85 Stainless Steel Perforated Extension
- 89 2" [51 mm] High External Water Dam
- 90 90° Threaded Side Outlet Body (2" [51 mm] thru 4" [102 mm])
(Previously Z126)

Z127 8-1/2" [216 mm] DIAMETER DECK RECEPTOR DRAIN

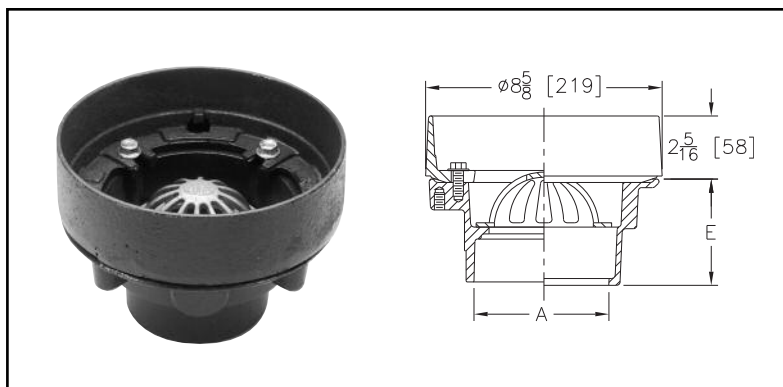

A Pipe Size Inches [mm]	Approx. Wt. Lbs. [Kg]
2 - 3 - 4 [51-76-102]	19 [9]

ENGINEERING SPECIFICATION: ZURN Z127 8-1/2" [216 mm] diameter Deck Receptor Drain, Dura-Coated cast iron body with combination membrane flashing clamp/deck receptor frame and internal dome strainer.

*Regularly furnished unless otherwise specified.

OPTIONS

OUTLETS (Specify pipe size in inches and type of outlet.)

OUTLET TYPE	OUTLET DESIGNATION Pipe Size/Outlet Type	'E' BODY HT. DIM. In./[mm]
Inside Caulk	21C, 31C, 41C	3-7/8" [98 mm]
Threaded	21P, 31P, 41P	2-5/8" [67 mm]
No-Hub	2NH, 3NH, 4NH	3-7/8" [98 mm]
Neo-Loc	2NL, 3NL, 4NL	3-3/4" [95 mm]

PREFIXES

Z	D.C.C.I. Body with Collar*
----------	----------------------------

SUFFIXES

- AR Acid Resistant Epoxy Coated Finish
- C Underdeck Clamp
- DP Top-Set® Roof Deck Plate (Replaces both the -C and -R)
- E 2" [51 mm] High Static Extension (Specify Height)
- G Galvanized Cast Iron
- HD High Dome
- R Roof Sump Receiver
- TC Neo-Loc Test Cap Gasket (2" [51 mm] to 4" [102 mm] NL Bottom Outlet Only)
- 90 90° Threaded Side Outlet Body (2" [51 mm] thru 4" [102 mm])
(See Z1043)