

RS232 CENTRONICS

CONVERTER



USER'S MANUAL

SXP-320A
SXP-325A

Read this guide thoroughly and follow the installation and operation procedures carefully to prevent any damage to the hub and/or any of the devices it connects to.

This package contains:

- 1 Bidirectional Serial/Parallel Converter (SXP-320A or SXP-325A)
- 1 AC 9V 200mA Power Adapter
- 1 User Manual

©Copyright 1999 ATEN® International Co., Ltd.
Manual Part NO. PAPE -1145-100
Printed in Taiwan 06/1999

All brand names and trademarks are the registered property of their respective owners.

Table of Contents

- Overview
- Features
- Installation
 - Default Configuration
 - DIP Switch Settings
 - Cabling
- Operation
- Appendix
 - Troubleshooting
 - Specifications
 - RS-232C Interface Specification
 - Centronics Interface Specification
 - Centronics Interface Timing Chart
 - Preventing Radio & TV Interference

Overview

The SXP-320A / SXP-325A are interface converters that allow Centronics and RS-232 devices to communicate with each other (a computer with an RS-232 output to a Centronics printer, for example).

Both units are bidirectional enabling you to convert from serial to parallel or parallel to serial. The primary difference between them is that the SXP-325A is configured with 512 KB of memory allowing it to serve as a printer buffer, whereas the SXP-320A has no memory.

These two way converters provide a DB-25 RS-232C (DCE) compatible connector, and a C-36 Centronics connector. The serial baud rate is from 1200 to 115200 bps. (selectable by DIP Switch). The parallel interface speed for the (non-buffered) SXP-320A is 11.52 KB/sec; for the (buffered) SXP-325A, it is 1.5 MB/sec.

The units support both hardware and software (XON/XOFF) handshaking. Setup is extremely easy. All that is involved is setting the DIP Switch and connecting the cables.

Front View

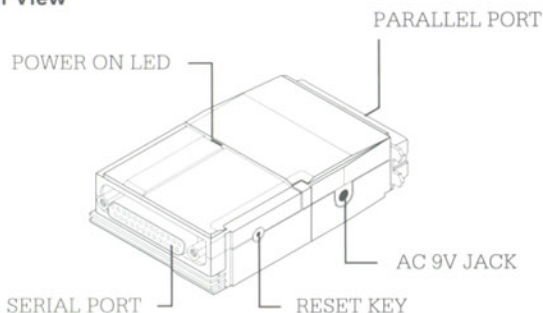

Rear View

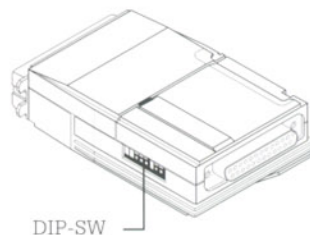

Features

- DIP Switch Sets Data Direction
- Built In Buffer for Efficient Operation (SXP-325A)
- Both Hardware and XON/XOFF Handshaking
- Easy Installation
- Compact Size

Installation

Switch Configuration Overview:

The SXP-320A/325A is configured by setting an eight segment DIP Switch as follows:

Switch	Purpose
1	
2	Baud rate setting
3	
4	Handshake setting
5	Data and Stop Bits setting
6	Parity setting
7	
8	Conversion Direction setting

An explanation of each DIP Switch setting is given below.
Note: 1. When the segment is set in the direction of the arrow, it is ON.

2. In each table, the default setting is highlighted

Setting the Switches

Baud Rate:

The baud rate is set with DIP Switch segments 1 - 3, as shown in the table, below

DIP Switch Segment			Baud Rate (bits per second)
1	2	3	
ON	ON	ON	1200
ON	ON	OFF	2400
ON	OFF	ON	9600
ON	OFF	OFF	14400
OFF	ON	ON	19200
OFF	ON	OFF	38400
OFF	OFF	ON	57600
OFF	OFF	OFF	115200

Handshake:

DIP Switch Segment		Handshake
4		
ON		XON/XOFF
OFF		Hardware

Data and Stop Bits:

DIP Switch Segment		Data Bits	Stop Bits
5			
ON		7	2
OFF		8	1

Parity:

DIP Switch Segment		Parity
6	7	
ON	Either	Parity Inhibit
OFF	ON	Even Parity
OFF	OFF	Odd Parity

Conversion Direction:

DIP Switch Segment	Conversion Direction
8	
ON	Parallel to Serial
OFF	Serial to Parallel

Cabling

Serial to Parallel:

When performing a Serial to Parallel interface conversion:

1. Plug the female end of a 25/9-pin to 25/9-pin male/female serial cable into the PC's serial port
2. Plug the male end of the 25-pin to 25-pin male/female serial cable into the SXP-320A/SXP-325A's serial connector
3. Plug the female end of a C-36 to C-36 male/female printer cable into the SXP-320A/SXP-325A's printer connector
4. Plug the male end of the C-36 to C-36 male/female printer cable into the printer.

Note: If your serial cable is long enough, you can plug the SXP-320A/SXP-325A directly into the printer, without the need for a printer cable.

5. Plug the Power Adapter into an AC source; plug the Power Adapter cable into the SXP-320A/SXP-325A's power jack.

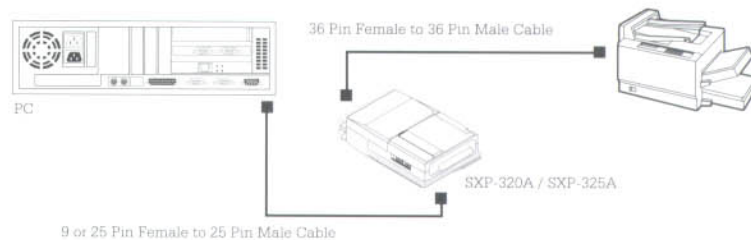

Parallel to Serial:

When performing a Parallel to Serial interface conversion:

1. Plug the male end of a 25-pin (male) to C-36 (female) printer cable into the PC's parallel port
2. Plug the female end of the 25-pin to C-36 male/female printer cable into the SXP-320A/SXP-325A's Centronics connector
3. Plug the male end of a 25-pin to 25-pin male/female serial cable into the SXP-320A/SXP-325A's serial connector
4. Plug the female end of the 25-pin to 25-pin male/female serial cable into the printer's serial port
5. Plug the Power Adapter into an AC source; plug the Power Adapter cable into the SXP-320A/SXP-325A's power jack.

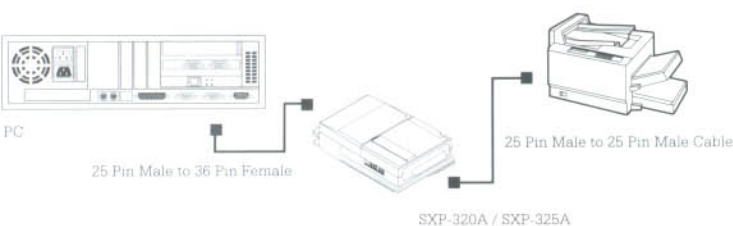

Serial Port Cabling

Device Connector's Pin #				Cables	SXP-320A / SXP-325A	
DCE DB-9	DTE DB-9	DCE DB-25	DTE DB-25	a 25-pin/25-pin cable or a 9-pin/25-pin cable		DCE DB-25
2	3	3	2	Tx ----->	Rx	2
3	2	2	3	Rx <-----	Tx	3
8	7	5	4	RTS ----->	CTS	4
7	8	4	5	CTS <-----	RTS	5
4	6	20	6	DSR ----->	DTR	6
6	4	6	20	DTR <-----	DSR	20
5	5	7	7	GND ----->	GND	7

Parallel Port Cabling

Device's Pin #		Cables	SXP-320A / SXP-325A	
DB-25	C-36	a 25-pin/36-pin Cables or a 36-pin/36-pin cable		C-36
1	1	STROBE	←	1
2-9	2-9	D0-D7	←	2-9
10	10	ACK	←	10
11	11	BUSY	←	11
12	12	PE	←	12
13	13	SLCT	←	13
14	14	AUTOFEED-XT	←	14
15	32	ERROR	←	32
16	31	INIT	←	31
17	36	SLCT-IN	←	36
18-25	19-30	GND	←	19-30

Operation

When operating the SXP-320A/SXP-325A, please take note of the following:

1. Since the SXP-320A/SXP-325A is a DCE device, the serial device it connects to must be configured as a DTE device.
2. In DCE mode, the unit uses RTS/DTR (pins 5 and 6) handshaking. When RTS/DTR is at +9V, the computer is allowed to transmit data. When the unit is busy, it sets the RTS/DTR line to -9V, and the computer stops transmitting data. Consequently, if the computer can not identify the RTS/DTR signal, it may result in data loss.
3. The unit is powered by the host RS-232C interface. In addition to the Tx/D line, it is recommended that the host RS-232C interface (MC 1488, SN 75188, or equivalent IC's), also support RTS and DTR lines, which provide a power source above $\pm 9V$, to ensure normal operation of the unit.
4. The unit's baud rate, data length, stop bits and parity settings must be configured to match those of the computer.
5. You must reset the parallel printer before printing.

RS-232C Interface Specification

The RS-232C Interface DCE mode (default) specification is given in the table, below:

Pin	Name	Function
1	Ground	Ground
2	RxD	Receive Data
3	TxD	Transmit Data
4	CTS	Clear to Send
5	RTS	Request to Send
6	DTR	Data Terminal Ready
7	Ground	Ground
8	CD	Pull Up (+9V)
20	DSR	Data Set Ready

Centronics Interface Specification

The Centronics Interface Specification is given in the table, below:

Pin	Name	Function
1	STB	DATA STROBE
2	DATA BIT 1	DATA BUS
3	DATA BIT 2	
4	DATA BIT 3	
5	DATA BIT 4	
6	DATA BIT 5	
7	DATA BIT 6	
8	DATA BIT 7	
9	DATA BIT 8	
10	ACK	DATA RECEIVED ACKNOWLEDGE
11	BUSY	DEVICE BUSY OR NOT
12	PAPER EMPTY	PULL UP
13	SLCT	PULL UP
14	A-F	PULL UP
15	N.C.	
16-17	GROUND	GROUND
18	N.C.	
19-30	GROUND	GROUND
31	INIT	PULL UP
32	ERR	PULL UP
33	GROUND	GROUND
34-35	N.C.	
36	SL-1	PULL DOWN

Appendix

Troubleshooting

Problem	Cause	Solution
Power LED does not light	Unit is not receiving power.	Make sure that there is no problem with the AC source, and that the AC adapter is fully operational. Make sure that the adapter is correctly plugged into the AC source and that the cable is fully plugged into the unit's power jack.
	No Data Transmission	Make sure that all cables are properly plugged in and fully seated in their connectors.
No Data Transmission	Cables are not properly plugged in.	Make sure that all cables are properly plugged in and fully seated in their connectors.
	Cables are not properly wired.	Rewire the cables making sure they are correctly wired
	Transmitting or Terminal device has not been set Ready for data transfer.	If powered Off, turn the device On. Otherwise, reset the Transmitting or Terminal device.
Incorrect Data Received	Transmitting or Terminal device is in incorrect DTE mode.	Change the Transmitting or Terminal device to the correct DTE mode, or user's cross line.
	Lines are not properly connected.	Rewire the cable lines to be sure they are properly connected.
Incorrect Data Received	Incorrect serial transmission DIP Switch settings	Set the DIP Switch segments to their proper settings.

If the above solutions fail to alleviate the problem, contact your dealer for help.

Centronics Interface Timing Chart

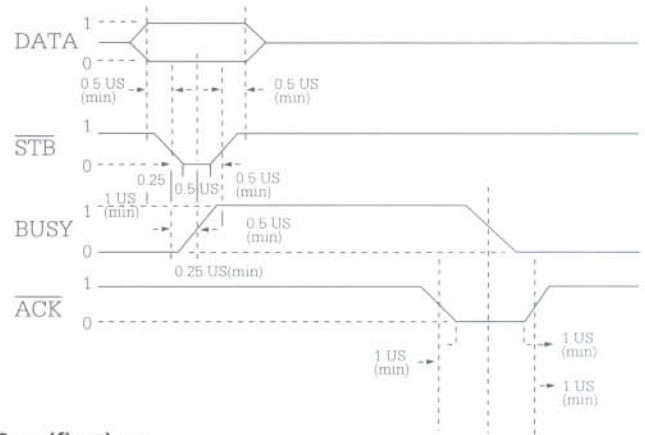

Specifications

Power Consumption	AC 9V 150mA (max.)	
Cable Distance	Up to 9 m (30')	
Connectors	RS-232C	DB-25 female DCE
	Centronics	C-36 male
Memory Size	512 KB(SXP-325A Only)	
Interface Exchange	In	Serial or Parallel
	Out	Parallel or Serial
Serial Communications Mode	DCE Only	
LEDs	Power (Green)	
Microcontroller	ASIC	
Function Key	Reset	
Buffer Speed	Serial	1200 - 115200 bps
	Parallel	1.5 MB/sec. (max.)
Data Compression	8.5 : 1 (max.)	
Temperature	Operating	5° - 40° C
	Storage	-20° - 60° C
Humidity	0 - 80%	
Housing	Plastic	
Weight	120 g	
Dimensions (L x W x H)	101 x 62 x 25.5 mm	

Radio & TV Interference

Warning. This equipment generates, uses and radiates radio frequency energy and if not installed and used in accordance with the instruction manual may cause interference to radio and television reception. It has been tested and found to comply with the limits for a Class A computing device in accordance with the specifications in Subpart J of Part 15 of the FCC Rules, which are designed to provide reasonable protection against such interference when operated in a commercial environment. Operation of this equipment in a residential area is likely to cause interference, in which case the user at his own expense will be required to take whatever measures may be required to correct the interference.

If this equipment does cause interference to radio or television reception, which can be determined by turning the equipment off and on, the user is encouraged to try to correct the interference by one or more of the following measures:

1. Reorient the receiving antenna.
2. Relocate the computer with respect to the receiver.
3. Move the computer away from the receiver.
4. Plug the computer into a different outlet so that the computer and receiver are on different branch circuits.
5. Ensure that the mounting screws, attachment connector screws and ground wires are tightly secured.
6. Ensure that good quality shielded and grounded cables are used for data communications.

If necessary, the user should consult the dealer or an experienced radio/television technician for additional suggestions.

Limited Warranty

IN NO EVENT SHALL THE DIRECT VENDOR'S LIABILITY FOR DIRECT, INDIRECT, SPECIAL, INCIDENTAL, OR CONSEQUENTIAL DAMAGES RESULTING FROM THE USE OF THE PRODUCT, DISK, OR ITS DOCUMENTATION EXCEED THE PRICE PAID FOR THE PRODUCT.

The direct vendor makes no warranty or representation, expressed, implied, or statutory with respect to the contents or use of this documentation, and especially disclaims its quality, performance, merchantability, or fitness for any particular purpose.

The direct vendor also reserves the right to revise or update the device or documentation without obligation to notify any individual or entity of such revisions, or update. For further inquiries, please contact your direct vendor.

Radio & TV Interference

This equipment has been tested and found to comply with the limits for a Class B digital device, pursuant to Part 15 of the FCC Rules. These limits are designed to provide reasonable protection against harmful interference in a residential installation. This equipment generates, uses and can radiate radio frequency energy and if not installed and used in accordance with the instructions, may cause harmful interference to radio communications. However, there is no guarantee that interference will not occur in a particular installation.

この装置は、情報処理装置等電波障害自主規制協議会(VCCI)の基準に基づくクラスA情報技術装置です。この装置を家庭環境で使用すると電波妨害を引き起こすことがあります。この場合には使用者が適切な対策を講ずるよう要求されることがあります。