







Specification:

1. Finish: See Table
2. Hardware: See Table
3. Hinge: Door: 700.0537.25 + 600.1234.05 (8 pcs)
4. Slide: USE58-300-18 + USCLIP2ND-4W (7 set)
5. leg levelers (4 pcs)
6. The tolerance is +/- 1/8"

Item number	Finish	Deco Hardware			
		Item number	Qty	Item number	Qty
VN2DAS-60-DW-NT	Dark Walnut	635-256BG	4	635-128BG	3
VN2DAS-60-NO-NT	Natural Oak	635-256MB	4	635-128MB	3
VN2DAS-60-WH-NT	White	635-256BG	4	635-128BG	3

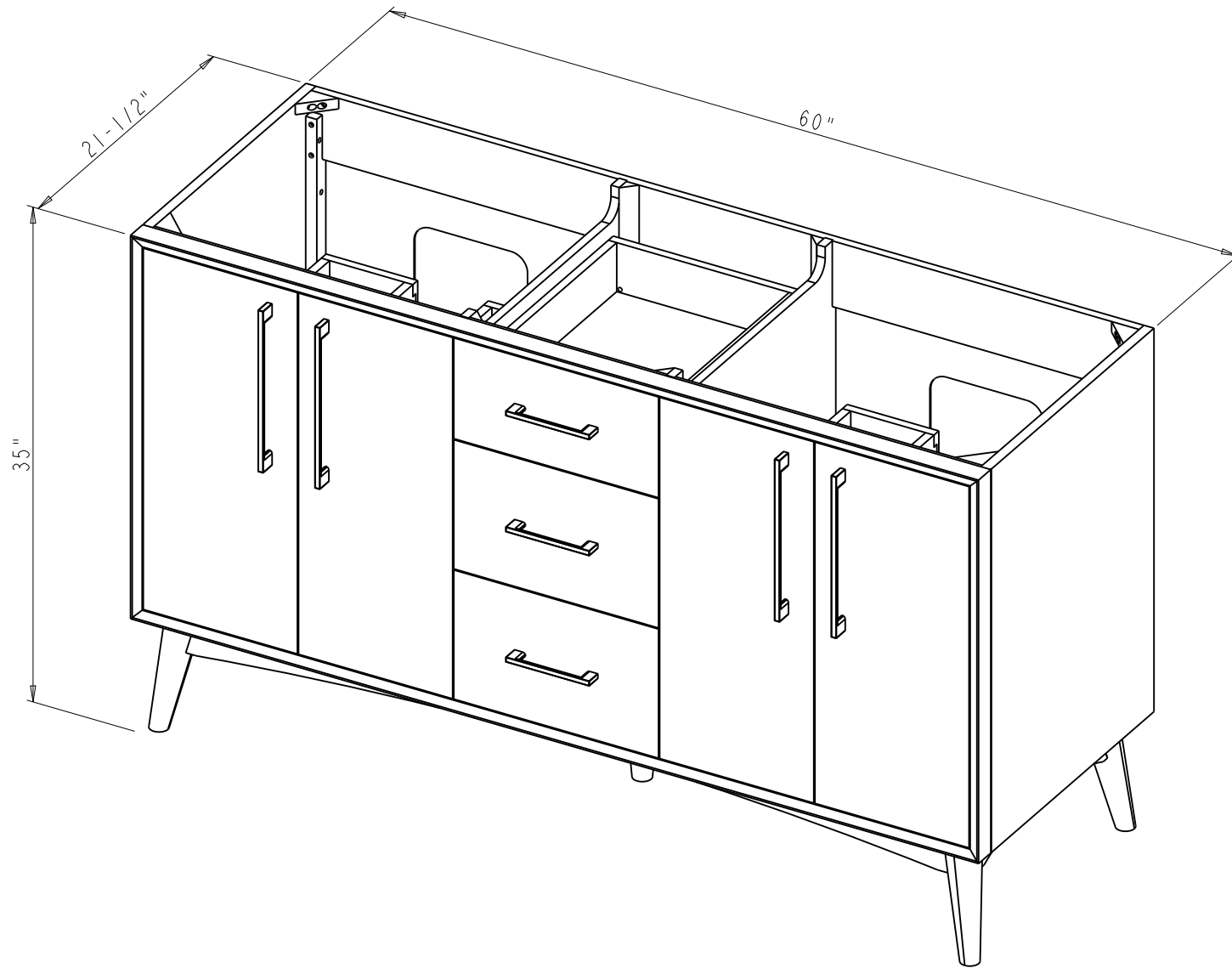
 <p>PROPRIETARY AND CONFIDENTIAL</p> <p>THE INFORMATION CONTAINED IN THIS DRAWING IS THE SOLE PROPERTY OF HARDWARE RESOURCES INC. ANY REPRODUCTION IN PART OR AS A WHOLE WITHOUT THE WRITTEN PERMISSION OF HARDWARE RESOURCES INC. IS PROHIBITED.</p> <p>DO NOT SCALE DRAWING</p>	ITEM#: VN2DAS-60	MATERIAL:	
	FINISH:	WEIGHT: 9	
	TOLERANCE UNLESS OTHERWISE SPECIFIED: X ±0.20 X.X ±0.10 X.XX ±0.05 ANGULAR: ±0.5°	UNITS: DRAWN BY: <i>Hugo.cai</i> APPROVED BY: RELEASE LEVEL:	DATE: Jan-09-23 DATE: REVISION:
	PROJECTION 	SHEET:	



 <p>PROPRIETARY AND CONFIDENTIAL</p> <p>THE INFORMATION CONTAINED IN THIS DRAWING IS THE SOLE PROPERTY OF HARDWARE RESOURCES INC. ANY REPRODUCTION IN PART OR AS A WHOLE WITHOUT THE WRITTEN PERMISSION OF HARDWARE RESOURCES INC. IS PROHIBITED.</p> <p>DO NOT SCALE DRAWING</p>	ITEM:	VN2DAS - 60		MATERIAL:	
	FINISH:			WEIGHT:	9
				PROJECTION	
	TOLERANCE UNLESS OTHERWISE SPECIFIED:	UNITS:	DRAWN BY:	DATE:	
X ±0.20		<i>Hugo.cai</i>	Jan-09-23		
X.X ±0.10	SIZE:	APPROVED BY:	DATE:		
X.XX ±0.05	SHEET:	RELEASE LEVEL:	REVISION:		
ANGULAR: ±0.5°					

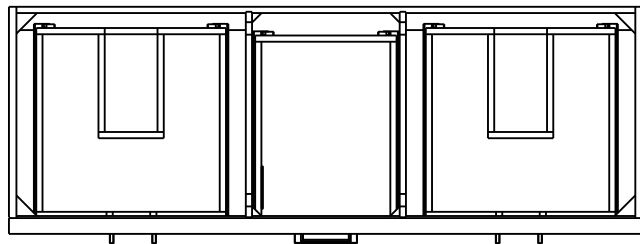
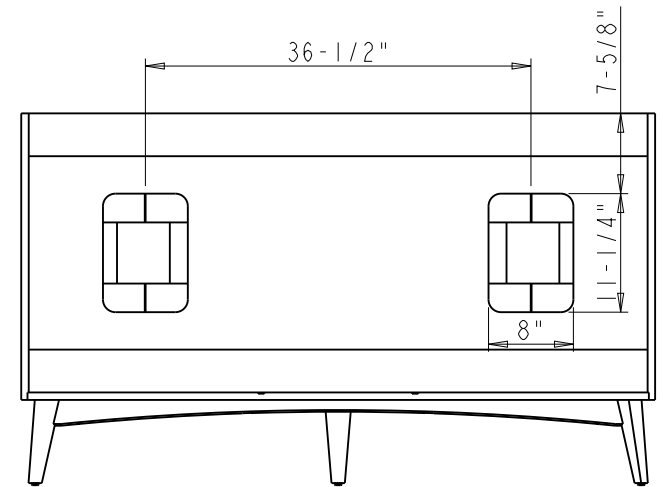
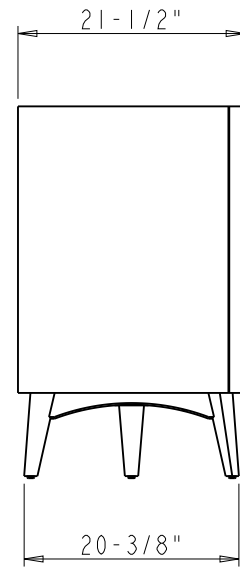
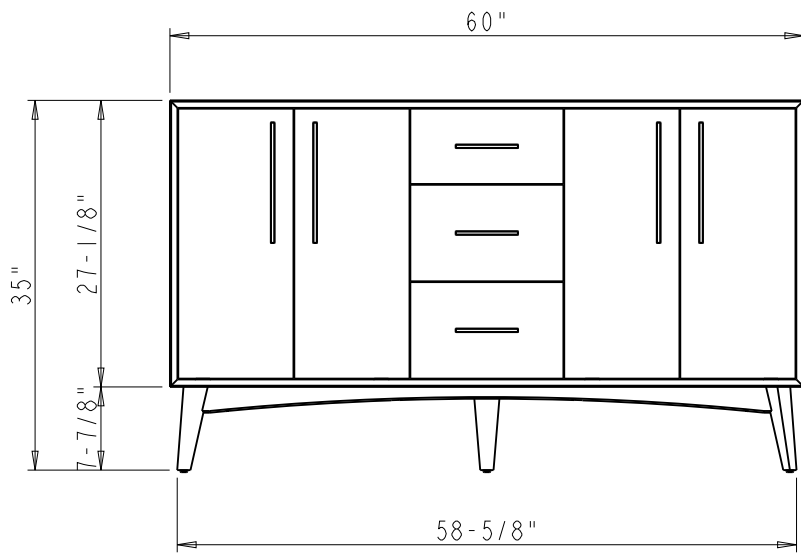

 <p>PROPRIETARY AND CONFIDENTIAL</p> <p>THE INFORMATION CONTAINED IN THIS DRAWING IS THE SOLE PROPERTY OF HARDWARE RESOURCES INC. ANY REPRODUCTION IN PART OR AS A WHOLE WITHOUT THE WRITTEN PERMISSION OF HARDWARE RESOURCES INC. IS PROHIBITED.</p> <p>DO NOT SCALE DRAWING</p>	ITEM#: VN2DAS-60	MATERIAL:	
	FINISH:	WEIGHT:	
	TOLERANCE UNLESS OTHERWISE SPECIFIED: X ±0.20 X.X ±0.10 X.XX ±0.05 ANGULAR: ±0.5°	UNITS:	DATE: Jan-09-23
	APPROVED BY:	RELEASE LEVEL:	REVISION:

