





HEKMAN®

A HOWARD MILLER COMPANY

ASSEMBLY INSTRUCTION FOR 26105 END TABLE

HARDWARE LIST

NO.	ITEM	DESCRIPTIN	QTY.
1		JCB Bolt M6X20 MM	24
2		Flat washer M8X16 MM	24
3		Allen wrench	1
4		JCB Bolt M6X16 MM	6

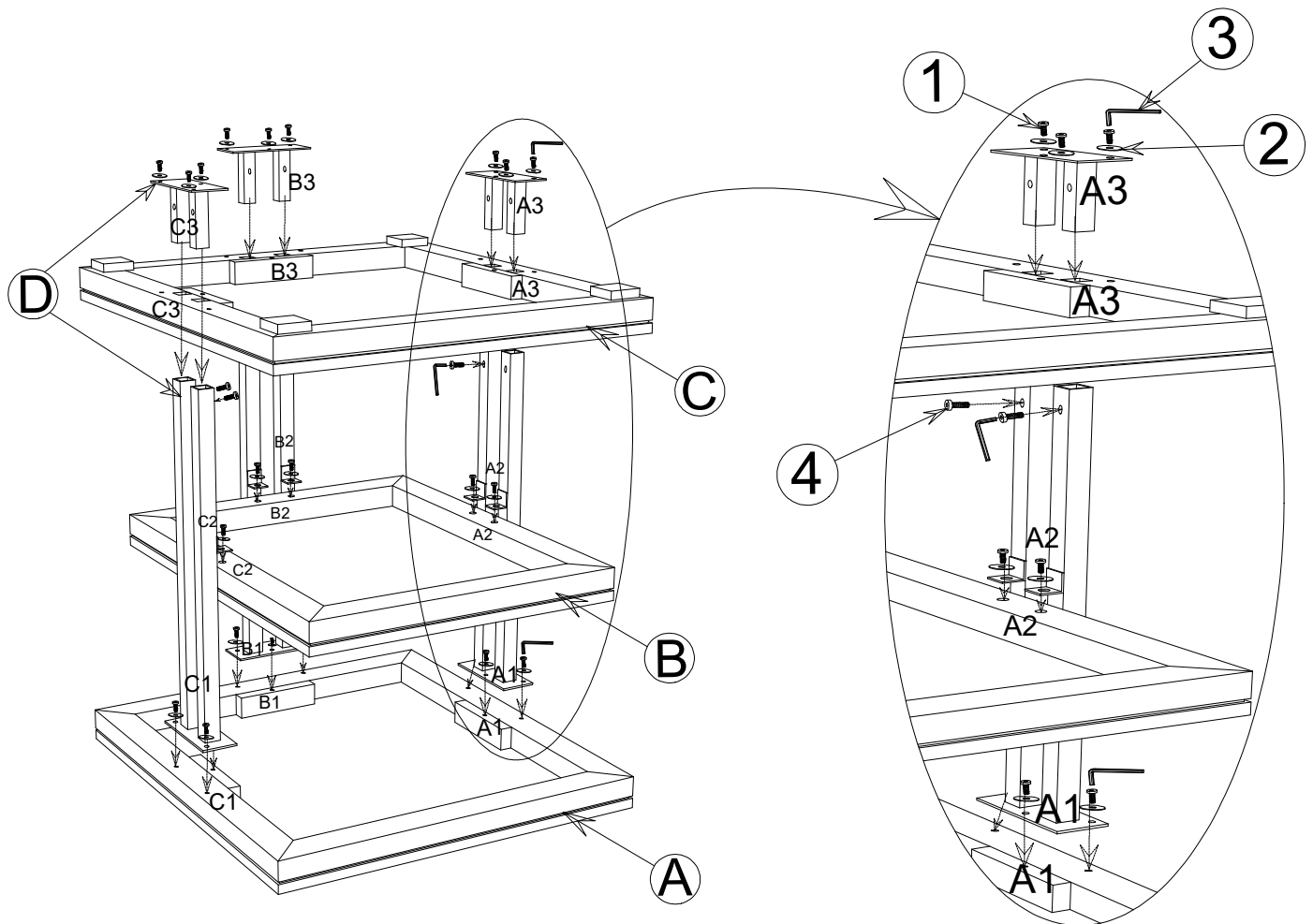
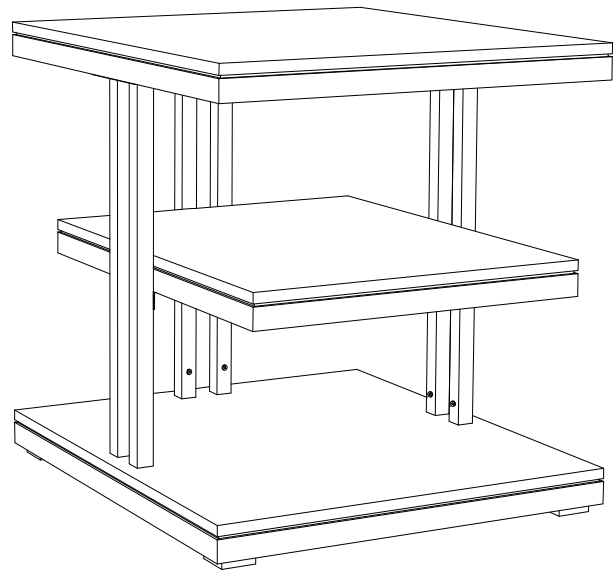

TO ASSEMBLY :

- STEP 1 : Unpack end table and turn the top (A) upside down. on a clean, soft surface.
- STEP 2 : Match the iron legs(D). use matching marks A1-A3, B1-B3 & C1-C3 - on top (A), shelf (B) & base assembly (C).
- STEP 3 : Align holes in legs (D) with holes on bottom of top (A), shelf (B) & bottom (C) and slide it into position.
- STEP 4 : Thread the flat washer(2) ,JCB bolt (1&4) to leg (D) . Do not tighten bolts fully until all bolts are started.
- STEP 5 : Tighten bolts in step 4 fully with allen wrench (3) then carefully turn the end table upright.