

BLACK DIAMOND®

Project Name: _____

Location: _____

Item #: _____

Qty: _____

Black Diamond Refrigerated Mega Top Salad/Sandwich Prep Table, 2 Doors, 47", in Stainless Steel

GRSLM-2D



Elevate your commercial kitchen operations with the Black Diamond Refrigerated Mega Top Salad and Sandwich Prep Table, designed for efficiency and durability. Constructed with high-quality stainless steel doors and a 14 cubic foot capacity, this prep table maintains a temperature range of 33° to 40°F. Featuring a fully automatic controller and R290 refrigerant, it ensures optimal performance and easy maintenance, making it an essential addition to your workspace.

FEATURES AND CONSTRUCTION

- 14 Cu. Ft. capacity, ideal for storing a variety of ingredients
- Equipped with a 0.75 horsepower compressor, ensuring efficient cooling performance
- Constructed from durable stainless steel for a professional look and longevity
- Maintains a temperature range of 33° to 40°F, perfect for food safety
- Utilizes R290 refrigerant, offering an eco-friendly cooling solution
- Operates on 115V with a NEMA-5-15P plug, ensuring compatibility with standard outlets
- Features adjustable shelving, providing customizable storage options
- Includes casters for easy mobility, enhancing its versatility in any kitchen
- Designed with user-friendly controls for precise temperature management
- Includes a polyethylene cutting board, offering a convenient workspace for preparation

ELECTRIC

115VV / Hz / 1Ph

Cord Length (Inches): 98.40"

Plug Type: NEMA 5-15P

Cord set included

NEMA 5-15P



3RD PARTY APPROVALS



WARRANTY (USA / CANADA)

Two (2) Year Limited Warranty on Parts and Labor, Five (5) Year Warranty on Compressor and Evaporator

Contact us for details at 1.877.368.2797



STORAGE CAPACITY

- Cubic Feet: 14 cu. ft.

TEMPERATURE

- Holding Temperature (Fahrenheit): 33° - 40°

These models are designed to operate in an environment where temperature and humidity do not exceed 75°F (24°C) and 55% relative humidity



Black Diamond 2 Door Refrigerated Mega Top Salad/Sandwich Prep Table - 47"

GRSLM-2D

FRONT

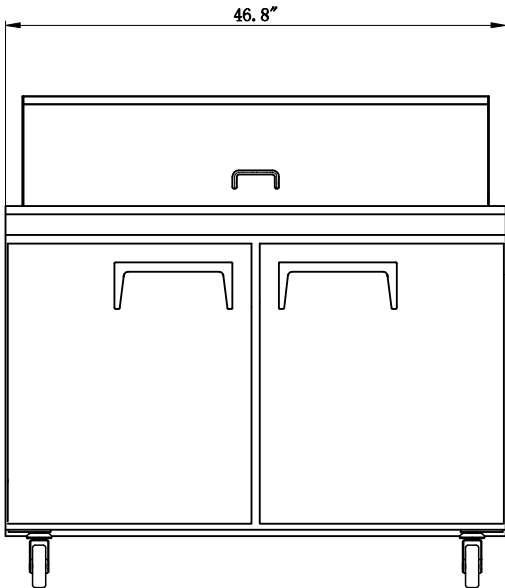

SIDE

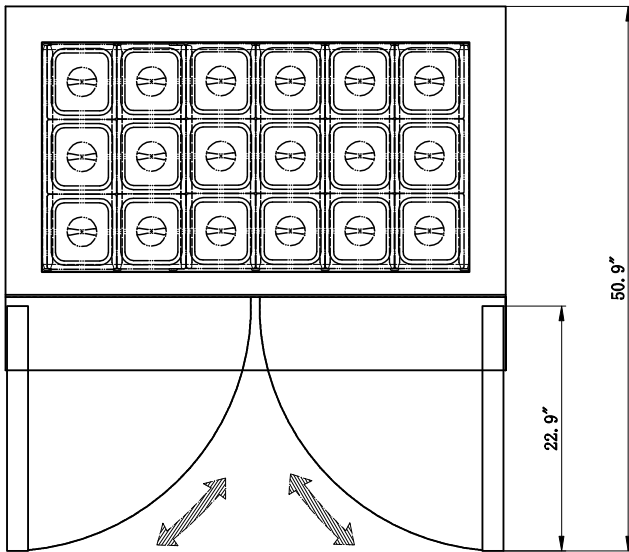
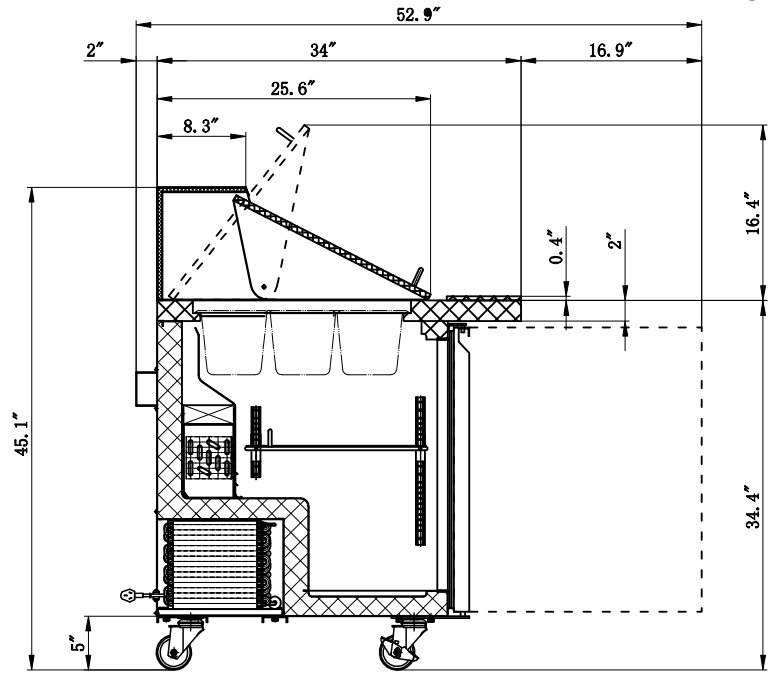

TOP

Prep Table

Doors	Shelves	Amps	HP	Refrigerant	Capacity	Assembled Dimensions (in)	Item Weight (lbs)	Shipping Weight (lbs)
2	2	4.9A	1/4	R290 3.883	14 cu. ft.	46.70" x 34.00" x 45.90"	275.0	370.0

Due to periodic changes in designs, methods, procedures, policies and regulations, the specifications contained in this document are subject to change without notice. While we exercise good faith efforts to provide information that is accurate, we are not responsible for errors or omissions in information provided or conclusions reached as a result of using the specifications. By using the information provided, the user assumes all risks in connection with such use.