

5.0 Gallon Straight Sided "Grease" Pail with Tear Skirt Cover

**Note: Available with UN-Solids Y25/S rating for Packaging Group II and III (USA & Canada)*

Multiple Uses

Grease Products
Silicon Products
Dry Products

Product Codes

Container: **7502, 5500 Series, 5556**
Description: 5.0 gallon 90 mil "Grease" Pail

Cover: **4580 Series**

Description: Tear Skirt "Grease" Cover

Note: **Multiple fitting and venting options available*

Features

Gauge: 90 mil.
Nominal capacity: 5.0 USG / 19.0 L
Tare weights: Body: 2.01 lbs. / .911 kgs
Cover: .61 lbs. / .275 kgs.

Specifications with Cover

Dimensions: 12-3/8" D X 13-9/16"H
Maximum capacity: 5.36 USG / 21.2 L
Tare weight: 2.62 lbs. / 1.19 kgs.

Colors

Standard: White, Black and Natural
Custom: Available at manufacturer's discretion

Decorating Options

Four color offset printing
Print area: 33"W x 8-1/2"H
Sleeve or pressure sensitive labeling

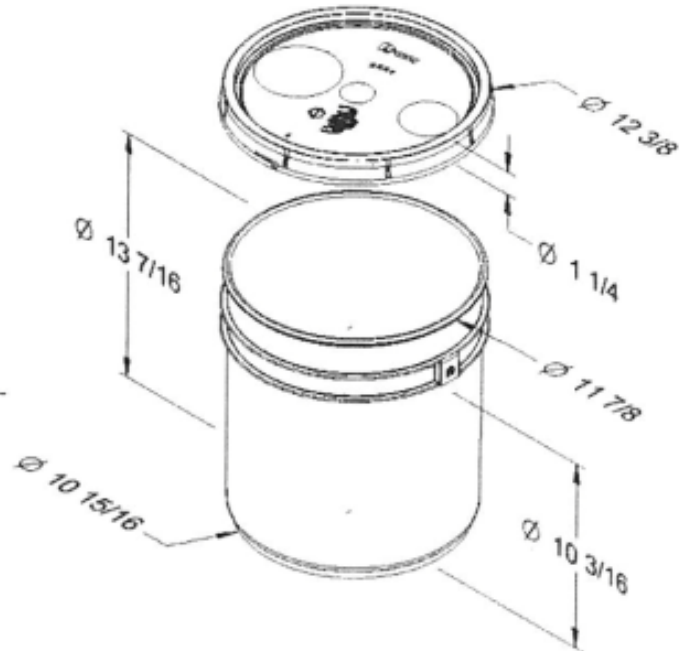

Shipping Data

Qty. per pallet/carton: 36*
Gross Weight (lbs/kgs.)**: 94 / 43
Length (in./cm.): 48 / 122
Width (in./cm.): 36 / 91.4
Height (in./cm.): 13.5 / 47

Packages

Filled Containers

36 (36 per layer / 1 layers high)
Pallet Height: 18.5"

Estimated truckload quantity of 1,008 bodies and covers***

Notes: *Quantity can vary based on customer request
**Weight does not include pallet/packaging
***Truckload quantity based on 53' trailer

Materials

FDA approved materials
Resin: Body: High-Density Polyethylene (HDPE)
Cover: High-Density Polyethylene (HDPE)
Gasket: Ethylene Propylene Diene Monomer (EPDM)

Optional Carrying Handle

Wire or Plastic

DISCLAIMER

This specification does not relieve the customer of their ultimate responsibility for the determination of the appropriate container. It is the customer's responsibility to select the appropriate packaging based upon all information at their disposal including the specific application, regulatory compliance, product compatibility and shipping requirements. WE HEREBY DISCLAIM AND EXCLUDE ANY EXPRESS OR IMPLIED WARRANTIES, INCLUDING WITHOUT LIMITATION THE IMPLIED WARRANTIES OF MERCHANTABILITY AND FITNESS FOR A PARTICULAR PURPOSE.

DISTRIBUTED BY:



REF NO.:

DWG30182

DESCRIPTION:

5 Gallon HDPE Straight Side "Grease" Pail With Tear Tab Cover