



FREESTYLE[®] GRIDDLE

Owner's Manual

F24DFT

Appliance illustrated in this manual
may differ from model purchased.

We Want Your Feedback!
Visit [Napoleon.com](https://www.napoleon.com) to write a review



Apply Serial Number



CONGRATULATIONS ON YOUR NAPOLEON® GRIDDLE!

You've Just Upgraded Your Cooking Game.

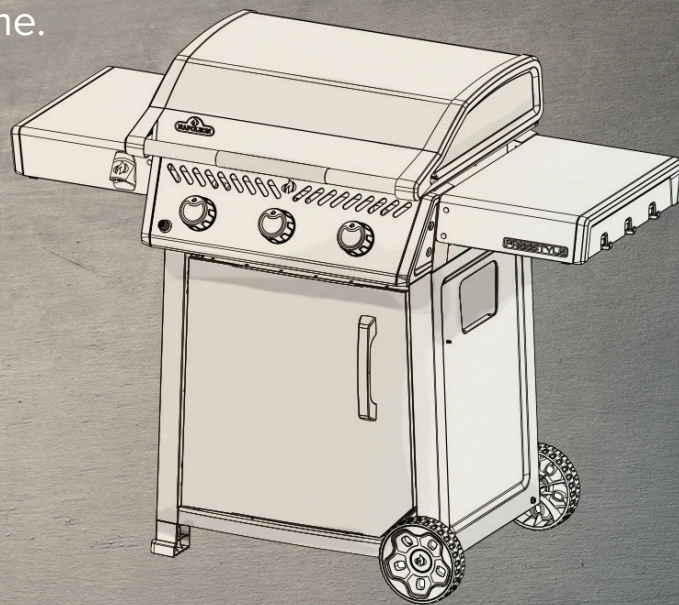

**OUR GOAL IS TO MAKE YOUR COOKING EXPERIENCE
BOTH MEMORABLE AND SAFE.**

🔥 Please read this Owner's Manual before using the appliance to avoid property damage, personal injury, or death.

🔥 Remove all packaging material, promotional labels and cards from the griddle before use.

USE OUTDOORS IN A WELL-VENTILATED SPACE.

⚠️ DANGER! ⚠️

IF YOU SMELL GAS:

- Shut off gas to the appliance.
- Extinguish any open flame.
- Open lid.
- If odor continues, keep away from the appliance and immediately call your gas supplier, or fire department.

⚠️ WARNING! ⚠️

- Do not try to light this appliance without reading the "LIGHTING" instructions section of this manual.
- Do not store or use gasoline, or other flammable liquids or vapors in the vicinity of this or any other appliance.
- An L.P. (propane) cylinder not connected for use must not be stored in the vicinity of this or any other appliance.
- If the information in these instructions is not followed exactly, a fire or explosion may result and cause property damage, personal injury, or death.



Alert adults and children about the hazard of hot surface temperatures.



Supervise young children near the grill.

NOTICE TO INSTALLER: Leave these instructions with the grill owner for future reference.
NOTICE TO CONSUMER: Keep these instructions for future reference.

Welcome to Napoleon!

Safety First

WARNING!

General Information

This griddle should be installed in conformity with local codes. If an external electrical source is utilized, the appliance must also be grounded in accordance with local codes.

WARNING!

Installation & Assembly

Assemble this griddle exactly as instructed in the Assembly Guide. If the griddle was assembled in-store, review the assembly instructions to ensure it is done correctly. Not to be installed in or on recreational vehicles and/or boats. Perform the required Leak Test before operating the griddle.

Do not modify this griddle under any circumstances. Do not use a cylinder that is not equipped with the appropriate type connection. Only use the pressure regulator and hose assembly supplied with this griddle or replacement parts specifically recommended by Napoleon.

WARNING!

Storage & Disuse

Turn off gas at the gas cylinder or natural gas supply valve. Disconnect the hose between the propane cylinder and griddle. Remove the propane cylinder and store outdoors in a well-ventilated space away from children.

DO NOT store gas cylinders in a building, garage, shed, or any other enclosed space.

WARNING!

Electrical Precautions

Keep all electrical supply cords and fuel supply hoses away from all heated surfaces. To protect against electric shock, do not immerse the cord or plug in water or other liquids. Always connect the plug to the appliance first, then plug the appliance into the outlet.

WARNING!

Operation

Read this entire Owner's Manual before operating this appliance. Leak Test this griddle before each use, annually and when any gas components are replaced. Follow the lighting instructions carefully.

WARNING!

Correct Product Disposal





This marking indicates that this product should not be disposed with other household wastes throughout the EU. To prevent possible harm to the environment or human health from uncontrolled waste disposal, recycle it responsibly to promote the sustainable reuse of material resources. To return your used device, please use the return and collection systems or contact the retailer where the product was purchased. They can take this product for environmental safe recycling.

CONTENTS

Welcome to Napoleon!	3
Safety First	3
Full System Features	5
Getting Started	6
Additional Safe Operating Practices	6
Locating your Griddle	8
Gas Connections	9
Technical Data	11
Leak Test	12
Operation	13
How to Season your Stainless Steel Griddle for the First Time	13
Lighting your Appliance	14
Cooking Instructions	15
The Cooking Experience Checklist	16
Cooking Guide	18
Cleaning Instructions	19
First Time Use	19
Griddle Plate	19
Drip Tray	20
Grease Chute	20
Control Panel	20
Outside Appliance Surface	21
Insect Screen and Burner Ports	22
Maintenance Instructions	23
Combustion in Air Adjustment	23
Stainless in Harsh Environments	24
Troubleshooting	25
Warranty	28

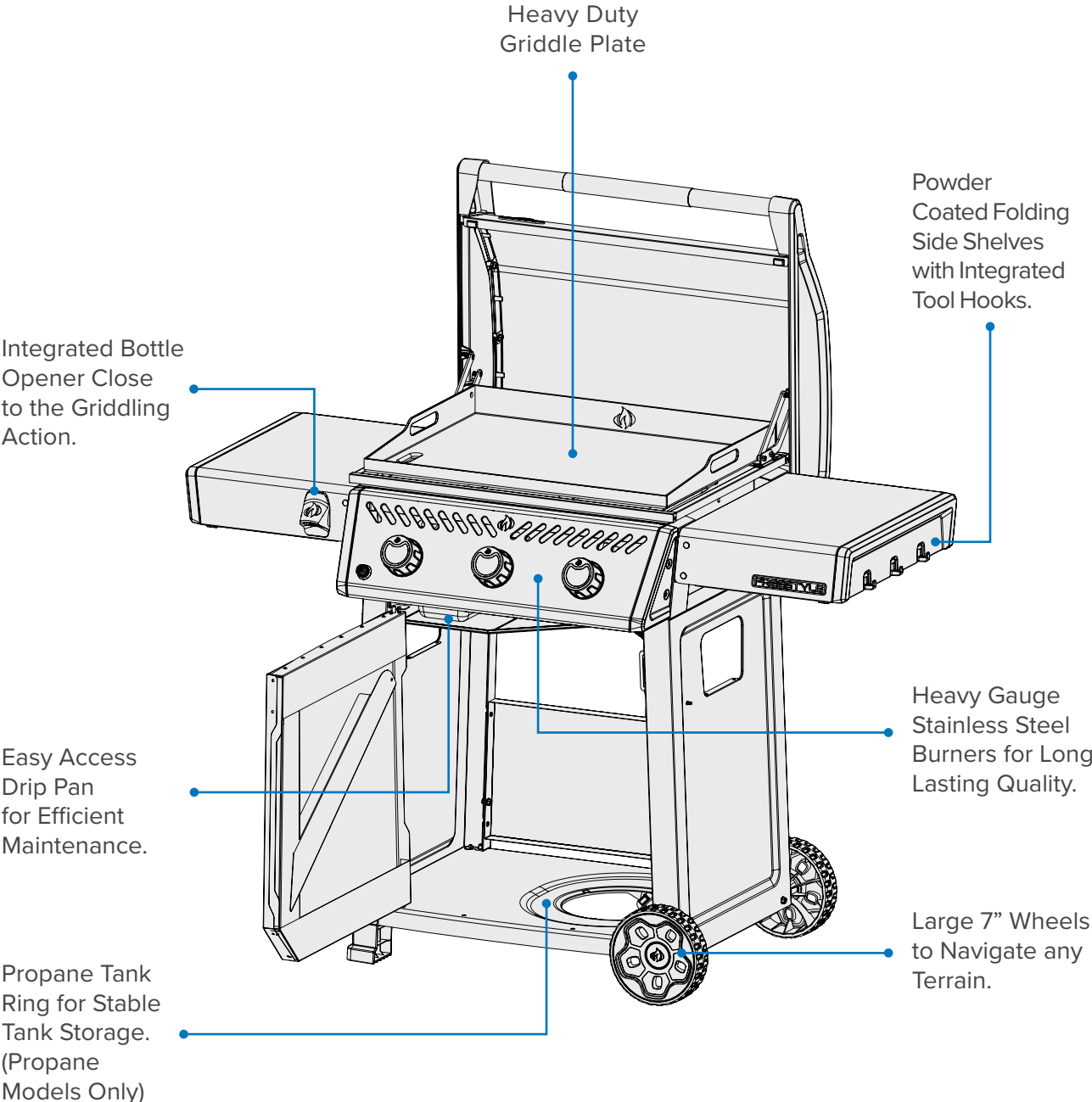
Full System Features



 The griddle illustrated in this Owner's Manual may differ from the model you purchased. Featured model: FREESTYLE F24DFT

Getting Started



DANGER!

Advise of a hazard that could result in a fire, explosion, death or serious physical injury.



WARNING!

Advise of a hazard that could result in minor physical injury or property damage.



Do not smoke while performing a gas leak test. Sparks or flames will cause a fire, explosion, damage to property, serious physical injury, or death.



Never use an open flame to check for gas leaks. Sparks or flames will cause a fire, explosion, damage to property, serious physical injury, or death.



CAUTION! Hot surface.



Immediately shut off the gas supply and disconnect.



Wear safety glasses.



Wear protective gloves.



Important Information.

Additional Safe Operating Practices

- Do not route the hose underneath the drip pan. Maintain proper hose clearance to the bottom of the unit.
- Burner controls must be off when turning the gas cylinder valve on.
- Do not light burners with the lid closed.
- Do not deep fry food on the side burner.
- Do not adjust the griddle when operating or hot.
- Do not move the appliance during use.
- Turn off the gas supply at the source after use.
- Do not modify the appliance.
- Maintenance should only be done when the griddle is cool.
- Do not store lighters, matches or any other combustibles inside the enclosure or condiment tray.
- Keep all electrical supply cords and fuel supply hoses away from all heated surfaces.
- Clean the drip tray regularly to avoid build-up and grease fires.
- Keep the burner venturi tubes free from spider webs and other obstructions by inspecting and cleaning regularly.
- Do not use a pressure washer to clean any part of the griddle.
- Do not locate this griddle where it can be exposed to high winds, especially when the wind can come from directly behind the appliance.



- Do not operate appliance under any combustible construction.
- Never obstruct the open area surrounding the griddle plate.
- This appliance must be kept away from flammable materials while in use.
- Always maintain proper clearance to combustibles 24" (609.6 mm) to rear of unit, 7" (177.8 mm) to sides.
- Additional clearance of 24" (610 mm) is recommended near vinyl siding or panes of glass.
- The minimum ambient operating temperature for safe use of the appliance is 0 °F (- 17.8 °C).



WARNING!

- The hook-up and installation of the gas and hose connection must be performed by a licensed gas fitter, and leak tested before operating the griddle.
- Ensure the hoses do not contact any high temperature surfaces of the griddle.
- Accessible parts may be very hot. Keep young children away.



Locating your Griddle

Ensure that the location for your gas griddle meets all clearance requirements to adjacent combustibles. This appliance is intended for use on an outdoor patio or in your yard.

- Use the appliance only in an above-ground, open-air location with natural ventilation and no stagnant areas. Ensure gas leakage and combustion products are dispersed quickly by wind and natural convection.
- Do not use the appliance in a building, garage, or other enclosed space.
- Do not integrate the appliance into built-in or slide-in construction.
- Do not block ventilation openings in the cylinder enclosure.

Any enclosure in which the appliance is used must meet one of the following requirements:

- The appliance is considered outdoors if installed in a shelter with walls on three sides but no overhead cover. **(Fig 1).**
- An appliance is considered to be outdoors if installed in a shelter with an overhead cover and no more than two sidewalls.
 - » The sidewalls may be parallel, as in a breezeway, or at right angles to each other. **(Fig 2 & Fig 3).**
- An appliance is considered outdoors if installed in a shelter with three sidewalls and an overhead cover, as long as 30% or more of the horizontal periphery of the enclosure is permanently open. **(Fig 4 & Fig 5).**



IMPORTANT!

- All openings must be permanently open.
- Sliding doors, garage doors, windows, or screened openings are not considered as permanent openings.

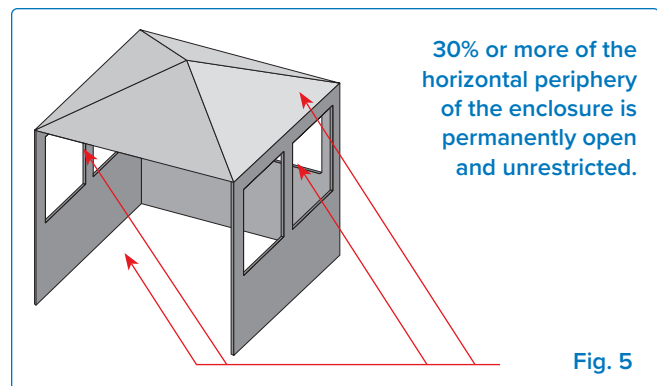
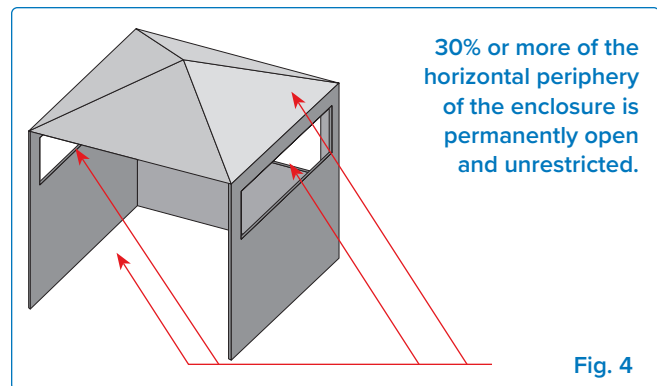
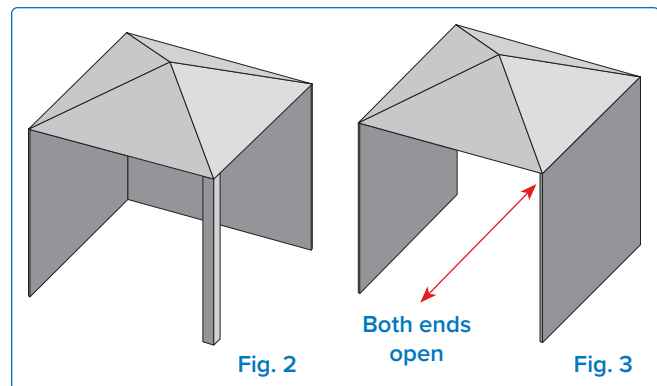
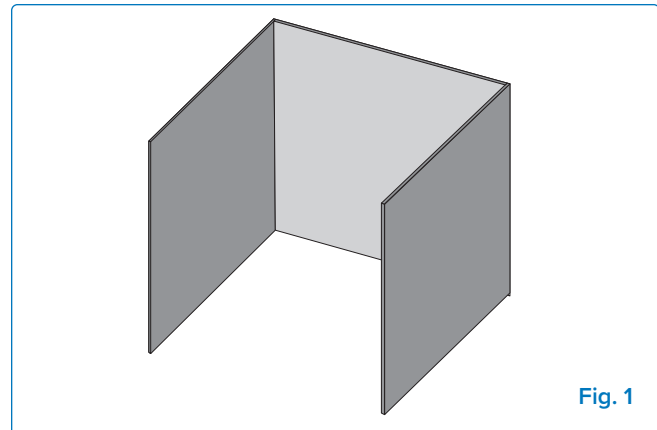

Gas Connections

To a Propane Cylinder

Use a propane cylinder of minimum 6 kg or a butane cylinder of 13 kg constructed and marked in accordance with national and regional codes. Ensure that the cylinder can provide enough fuel to operate the appliance. If in doubt, check with your local gas supplier.

Use a gas pressure regulator and hose supplied by Napoleon; if not included, use a regulator and hose that meet European Norm and regional codes. For South Africa, a SANS 1237 approved regulator must be used. The recommended length of the hose is 0.9 m. The hose must never be longer than 1.5 m.

 **NOTE:** The hose should be replaced before the expiry date printed on it.

Only place cylinders within the maximum width and height dimensions inside the enclosure on the bottom shelf. Cylinders that surpass the maximum dimensions must be placed outside the enclosure on level ground. Refer to the diagram for specific measurements.

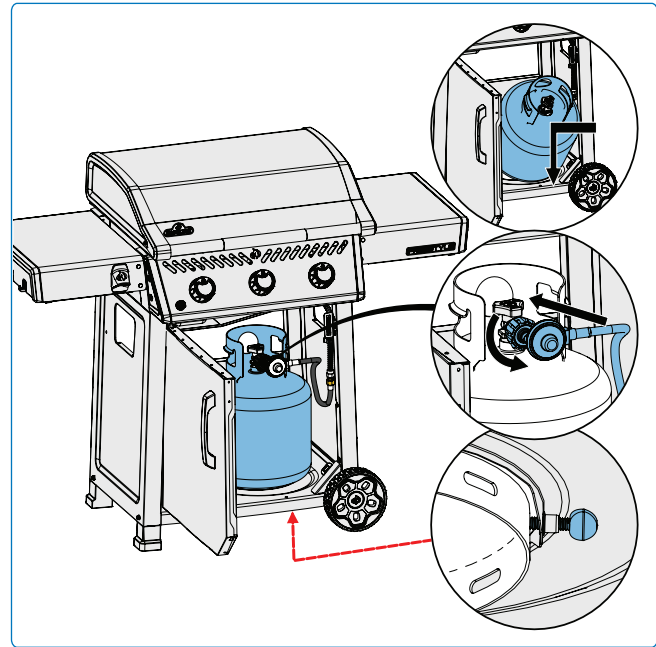

WARNING!

- Follow all specifications and instructions exactly to prevent fire, explosion, property damage, personal injury, or death.
- Never use a gas cylinder that is beyond 80% full.
- Disconnect the griddle and its individual shutoff valve from the gas supply piping system during any pressure testing in excess of ½ psi (3.5 kPa).

Hook-up and Installation

- Check the cylinder for dents or rust, and have it inspected by your gas supplier.
- Never use a cylinder with a damaged valve.
- Place the cylinder in its designated area on the bottom shelf.
- Ensure the gas regulator hose has no kinks.
- Remove the cap or plug from the cylinder fuel valve.
- Tighten the regulator to the cylinder valve.
- Ensure the hose does not contact with the drip pan or any high temperature surfaces of the griddle because it will melt and cause a fire.
- Ensure the cylinder is not left exposed to extreme heat or direct sunlight.
- Leak test all joints prior to operating the griddle. See “**Leak Test**” section.

 **NOTE:** Inspect the gas cylinder valve seal for cracks, wear, or deterioration each time the cylinder is replaced or refilled.

Any gas cylinder showing signs of damage or deterioration, including visible cracks and pitting, must be returned unused to the seller.

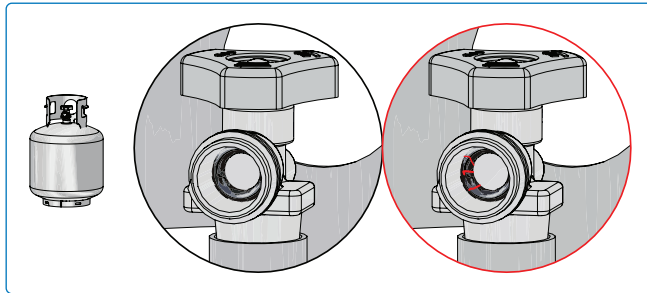

Maximum Cylinder Dimensions

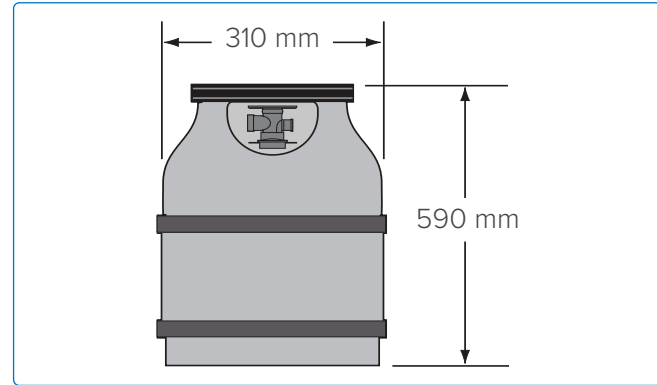

WARNING!

- Close the individual shutoff valve to isolate the griddle from the gas supply piping system during any pressure testing equal to or less than ½ Psi (3.5 kPa).
- Check the hose for evidence of excessive abrasion, melting, cuts or cracks. If the hose is damaged, it must be replaced with an assembly specifically recommended by Napoleon.
- Follow all specifications and instructions exactly to prevent fire, explosion, property damage, personal injury, or death.



BE CAREFUL!

The griddle and the entire firebox can become very hot when in use.

Technical Data

The following table lists gross heat input, gas usage values and orifice sizes corresponding to each burner per Gas Category:

	Orifice Size		Gross Heat Input (Total)	Gas Usage (Total)
	I	II	I / II	I / II
Main	0.77 mm	0.70 mm	7.65 kW	557 g/h

The following table lists all certified gases and pressures. Verify the information on the rating plate corresponds with this list.



NOTE: Only use regulators that supply the pressure listed here.

Gas Category	3B/P(30)	3+(28-30/37)	3B/P(37)	3B/P(50)
Orifice Sizes	I	I	I	II
Gases / Pressures	Butane 30mbar Propane 30mbar	Butane 28-30mbar Propane 37mbar	Butane 37mbar Propane 37mbar	Butane 50mbar Propane 50mbar
Countries	AL, BE, CY, CZ, DK, EE, FI, FR, GB, GR, HR, HU, IS, IT, LT, LU, MT, NL, NO, PL, RO, SE, SI, SK, TR	BE, CH, CY, CZ, ES, FR, GB, GR, IE, IT, LT, LU, LV, PL, PT, SI, SK, TR	PL	AT, CH, DE, SK



REGISTER YOUR APPLIANCE!

Go to napoleon.com or your Assembly Guide for replacement part instructions.

Leak Test

Why and When to Leak Test?

A leak test confirms no gas is escaping after you connect the hose to the gas supply.

Each time the tank is refilled and reinstalled, ensure that there are no leaks in the fitting where the regulator connects to the tank.

Leak test this griddle before use, annually, and when any gas components are replaced.

Leak Test Steps

1. Do not smoke while performing the test.
2. Remove all sources of ignition.
3. Turn all burner controls to the off position.
4. Turn the gas supply valve on.
5. Brush a half-and-half solution liquid soap and water onto all joints and connections of the regulator, hose, manifolds, and valves.
6. Bubbles indicate a gas leak.

If you Find a Leak

1. Tighten any loose joints.
2. If the leak cannot be stopped, immediately shut off the gas supply and disconnect the griddle.
3. Have the griddle inspected by a certified installer, or dealer.
4. Do not use the griddle until the leak has been fixed.

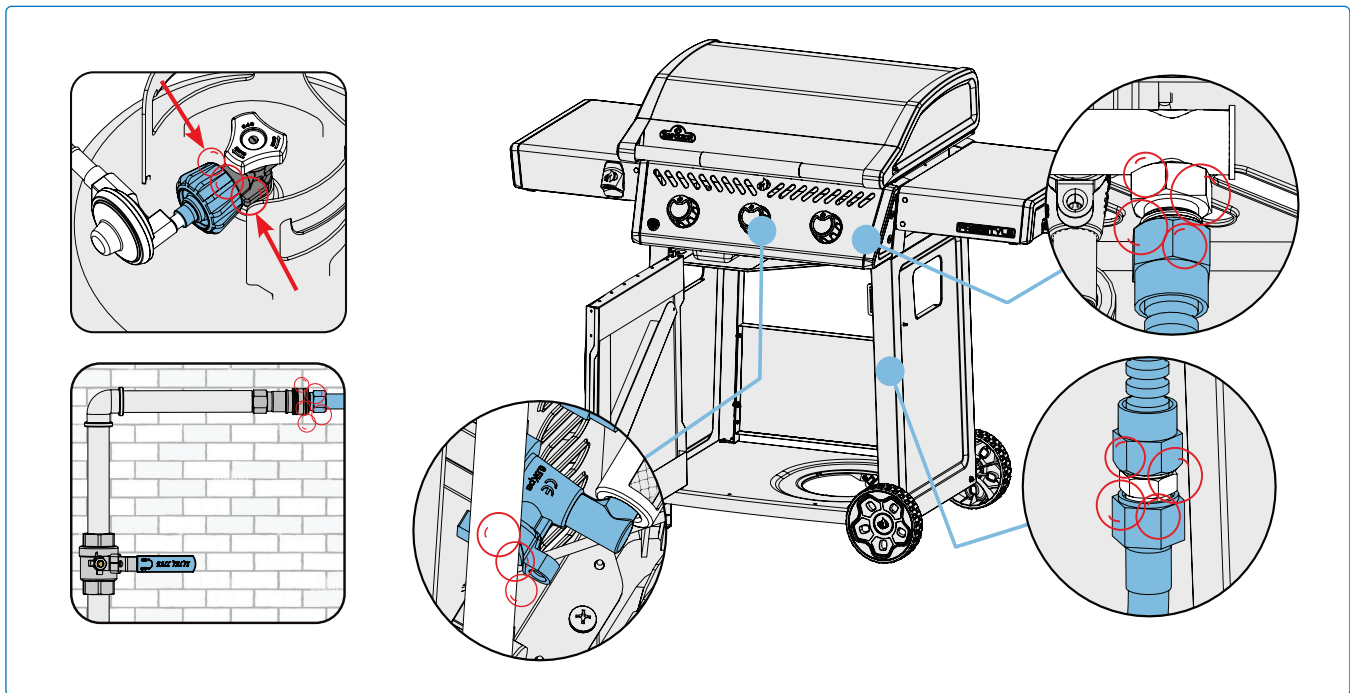
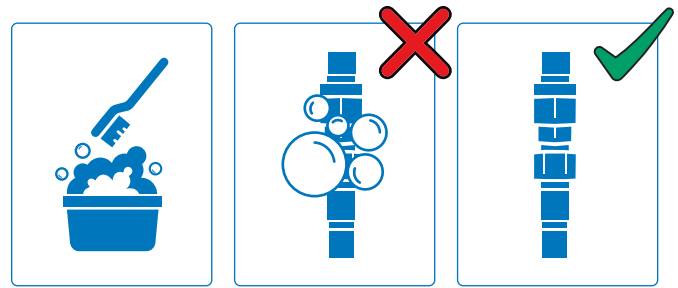

DANGER!

- Never use an open flame to check for gas leaks. Sparks or flames will cause a fire, explosion, damage to property, serious physical injury, or death.
- Only use the pressure regulator and hose assembly supplied with the griddle, or one in conformity with local codes.

Operation

How to Season your Stainless Steel Griddle for the First Time

Before First Use

Proper seasoning is important to ensure you get the best cooking results and prolong the lifespan of your griddle.

1. Wash the griddle with warm, soapy water to remove any factory residues. Rinse and dry completely.
2. Choose a high-smoke-point oil such as avocado oil. Sparingly apply enough oil to lightly coat the griddle surface.
3. With the griddle plate installed, follow “**Lighting Your Appliance**” section.
4. Heat the griddle on medium until the oil smokes and the surface darkens, indicating it’s bonding with the stainless steel. Let the smoke dissipate naturally (10–15 minutes), then turn off all burners and allow the griddle to cool completely.
5. Once the griddle has cooled, use a paper towel to wipe off any excess oil or residue. Ensure only a thin, even layer remains to prevent stickiness.
6. Repeat the oiling and burning-off process **2–4 times** to build a durable, non-stick protective coating. This seasoning strengthens with each layer, making future cooking and cleaning easier.

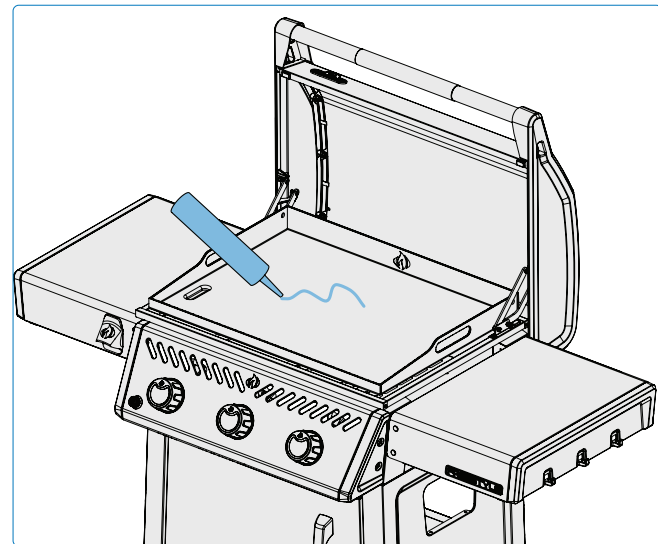
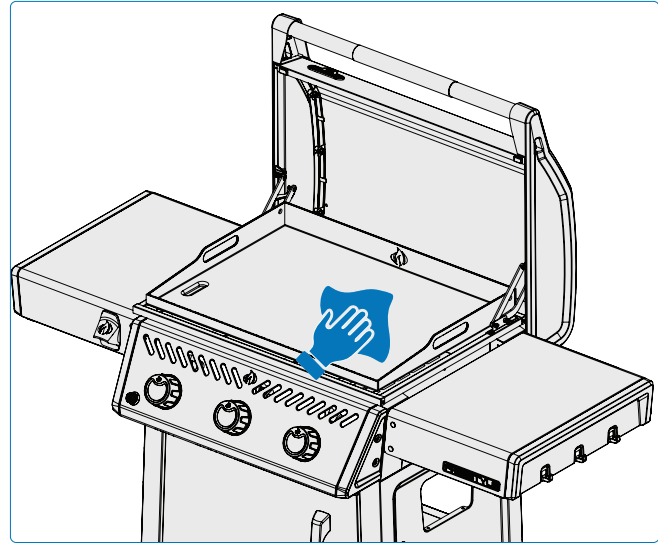

LEARN MORE

Scan the QR code to watch a step-by-step video guide on seasoning your griddle.



DID YOU KNOW?

Before storage, apply a very light coat of oil to maintain protection and prevent discoloration.



WE WANT TO HELP

Napoleon is here to ensure your cooking experience is memorable. Contact us if you require additional help.

Lighting your Appliance

Is it the Very First Time? Perform a Burn-off

Run the burners on high for 30 minutes with the lid open. It is normal for the appliance to emit an odor the first time it is lit. This odor is caused by the “burn-off” of internal paints and lubricants used in the manufacturing process and will not occur again.

Burner Lighting

1. Open appliance lid.
2. Push and turn the desired control knob to the high position. Press and hold the electronic igniter button until the burner lights, or light with a match. **(Fig. 6).**
3. Turn the control knob clockwise to the OFF position and wait 5 minutes for gas to dissipate. **(Fig. 6).**
4. Repeat step 2, or light with a match.

Lighting with a Match

1. Clip the match into the supplied lighting rod.
2. Insert the lit match to the side underneath the griddle plate.
3. While turning the corresponding burner knob to high. **(Fig. 7).**

NOTE: In the event of a power outage, the appliance can be lit with a match.

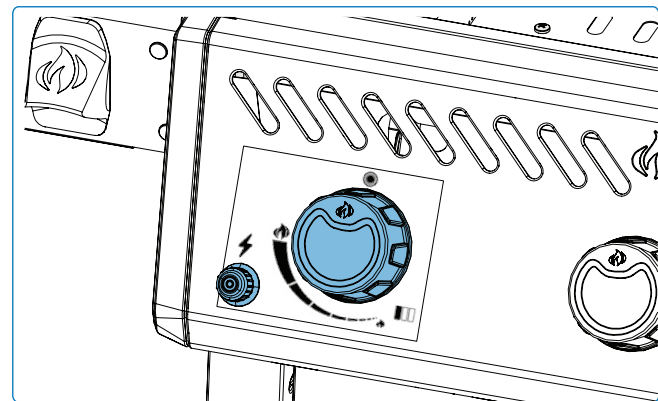
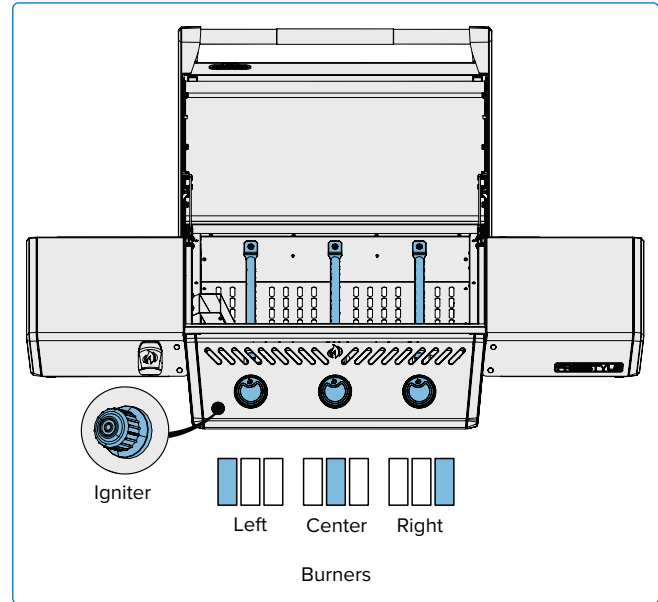

Fig. 6

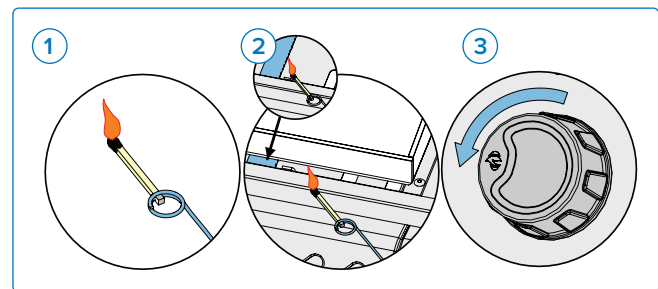
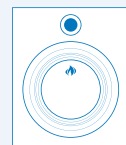

Fig. 7

! WARNING!

- Ensure all burner controls are in the OFF position before slowly turning on gas supply valve.
- Follow the lighting instructions carefully.
- Make sure the lid of the griddle is OPEN while igniting.
- Do not adjust the cooking griddle while is hot, or operating.
- Regularly clean grease out of the entire unit, including the grease tray to avoid build-up and grease fires.



Cooking Instructions

Burner Use

- Refer to “**How to Season Your Stainless Steel Griddle for the First Time**” section.
- Always keep the lid open when preheating and cooking.
- Set different burners to different heat levels to create specific temperature zones. Monitor the griddle surface temperature with an infrared thermometer to ensure each zone is at the desired heat level. Use direct heat (placed directly over lit burners) for foods that benefit from quick cooking, while indirect heat (placed off to the side) can be used for slower cooking or to keep food warm. **(Fig. 8)**
- Food is more likely to stick to the griddle plate if it is not hot enough. The temperature of the griddle can be determined using a non-contact infrared thermometer. Alternatively, pour a few drops of water on the griddle.
 - » Puddling and slow evaporation indicates low heat.
 - » Water sizzling and evaporating quickly indicates medium heat.
 - » Droplets hovering across the surface indicate high heat.
- The griddle plate should be oiled before cooking to prevent food from sticking.
- Use the griddle plate to melt or warm sauces. Place pots or pans off to one side over low to medium heat. **(Fig. 10)**.

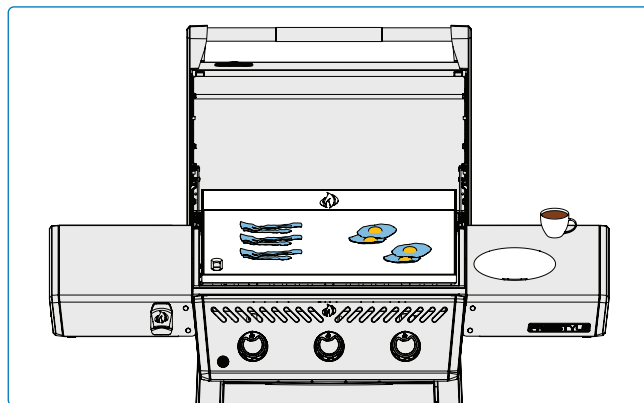

Fig. 8

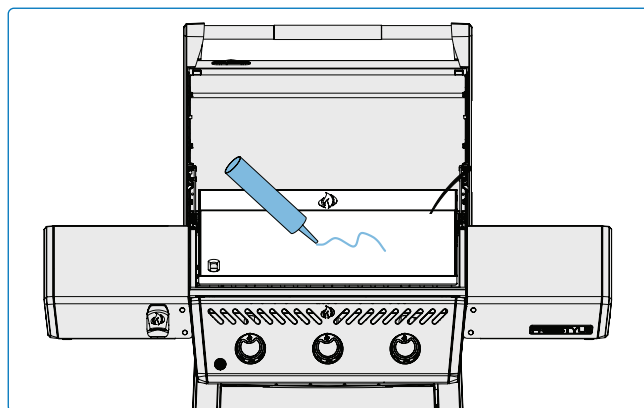

Fig. 9

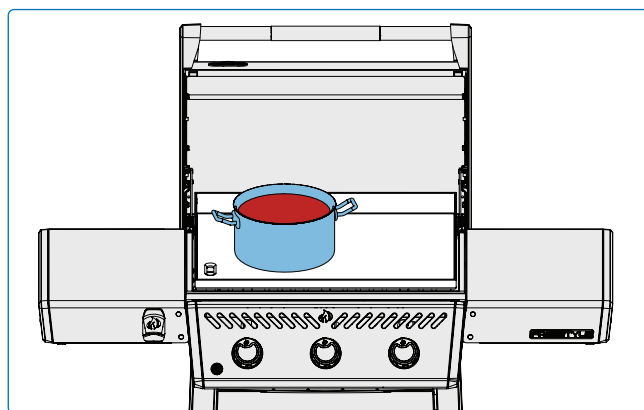

Fig. 10

DANGER!

- Never close the lid of the appliance when operating or hot. Let the appliance cool completely before closing the lid.
- Do not leave food unattended.
- Never use a gas cylinder that is beyond 80% full.
- Regularly clean grease out of the entire unit, including the grease tray, to avoid build-up and grease fires.



COOKING PRO TIP!

Use a thermometer to check the internal temperature of meat to ensure it is cooked perfectly.

The Cooking Experience Checklist

Refer to this list every time you cook

Read Owner's Manual

Be sure to have read the owner's manual and all the safety instructions.

Clean Grease Tray

Always ensure you clean the grease tray prior to griddling to avoid fires and flare-ups.

Check the Hose

Ensure the griddle is off and cool. Check the hose for evidence of excessive abrasions, or cuts. Have the hose replaced before use if the hose is damaged.

Preheat the Appliance

Preheat your appliance to its lowest setting and apply a small amount of cooking oil to the griddle plate.

Prep Area

Make sure everything you need while griddling such as your utensils, seasonings, sauces, and dishes are within your reach. Don't leave your food unattended, or it could burn.

Leave Space

Leave some space on the griddle and between food, so you have room to move food around if you need to.

Use a Thermometer

Use a thermometer to ensure food is cooked thoroughly. Follow the appropriate temperatures guidelines for all types of meat, especially poultry.



IMPORTANT!

- **Don't Overdo the Oil:** Too much oil can cause sticky or uneven seasoning that flakes off rather than bonding to the griddle surface.



NOTE:

It is recommended to clean the griddle plate after every use. See "**Cleaning Instructions**" section.



OIL AND FAT SUGGESTION!

- Grapeseed Oil,
- Sunflower Oil,
- Flaxseed Oil,
- Avocado Oil
- Canola Oil.

If not available, select an oil or fat that has a high smoke point.

Do not use salted fats like butter or margarine.



COOKING PRO TIP!

Discover inspiring recipes and griddling techniques in Napoleon's cookbooks or visit www.napoleon.com

Adjusting the Griddle Plate for Drainage

Proper grease drainage helps maintain consistent cooking performance. Ensure the griddle plate is cool and free of grease before making adjustments.



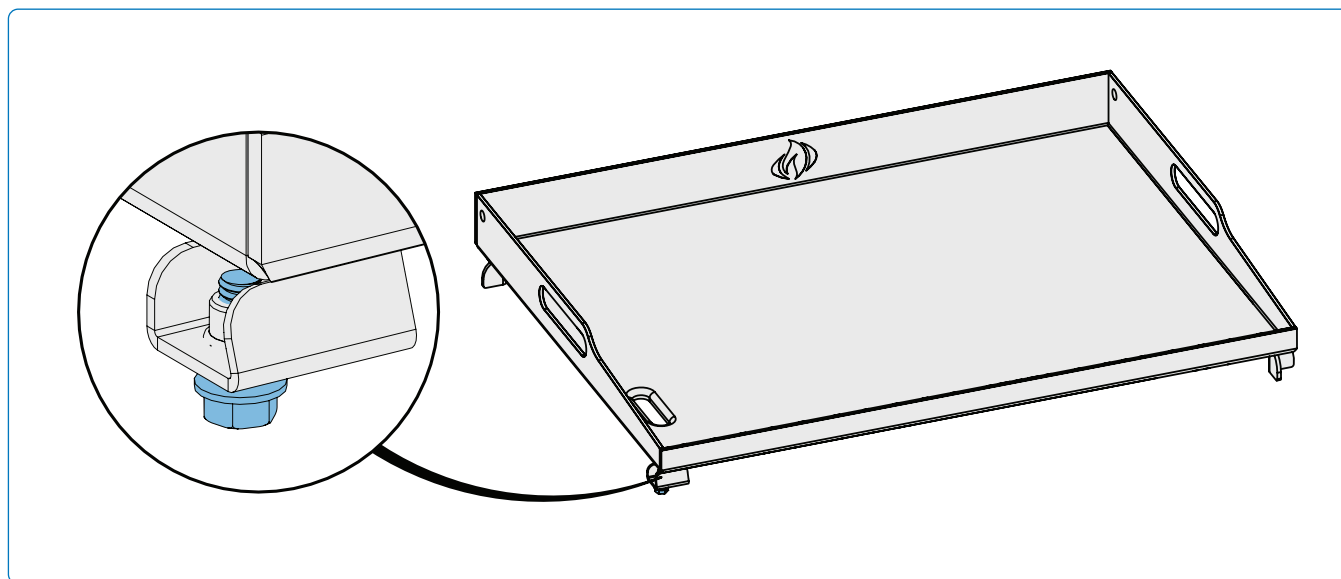

1. **Locate the Adjustment Screw:** Find the screw on the front left corner of the griddle plate. This screw is used to adjust the tilt of the griddle and control the direction of the grease drainage.
2. **Determine the Desired Level:** To ensure optimal grease drainage, the griddle plate should be slightly tilted towards the front left corner. This helps direct excess grease into the collection system.
3. **Adjust the Level:** With the griddle plate removed from the appliance, use a wrench or driver to turn the screw clockwise to raise the left corner of the griddle plate, or counterclockwise to lower it. Make small adjustments. Once adjusted to your satisfaction, reinstall the plate into the appliance.
4. **Test Drainage:** Heat the griddle and test the grease flow to confirm the setting. Excess grease should flow slowly and smoothly towards the drainage area without pooling. Repeat the adjustment process if necessary.



WARNING!

- The griddle plate is heavy and requires careful handling during removal and installation to prevent personal injury or damage to the appliance. Enlist the help of another person if necessary.

Cooking Guide

Food	Control Knob Setting	Cooking Time	Suggestions
 Steak 1 inch (2.54 cm) thick.	HIGH 2 minutes each side.	Rare – 4 minutes	Ask for marbled fat in cut. Fat is a natural tenderizer and keeps meat juicy.
	HIGH to MEDIUM High heat 2 minutes each side then turn to medium heat.	Medium – 6 minutes	
		Well Done – 8 minutes	
 Hamburger ½ inch (1.27 cm) thick	HIGH 2 minutes each side.	Rare – 4 minutes	Keep patties all the same thickness for equal cooking times. Patties 1 inch thick or more should be cooked using indirect heat.
	HIGH 2 ½ minutes each side.	Medium – 5 minutes	
	HIGH 3 minutes each side.	Well Done – 6 minutes	
 Pork Chops	MEDIUM	6 minutes each side	Choose thick cuts for more tender meat. Trim off excess fat.
 Lamb Chops	HIGH to MEDIUM High for 5 minutes then Medium until finished.	15 minutes each side	Choose thick cuts for more tender meat. Trim off excess fat.
 Hot dogs	MEDIUM to LOW	4 – 6 minutes	Select larger wieners and slit lengthwise before cooking.

These are general guidelines.
 Please refer to the health authority recommendations for more detailed information.



COOKING PRO TIP!

Choose the right kinds of food to cook. Your griddle excels at cooking foods hot and fast.

Although you can cook large chunks of meat on a griddle over a low heat, a Napoleon gas or charcoal griddle will produce better results.



COOKING PRO TIP!

Applying a thin layer of cooking oil to the griddle plate will help prevent delicate foods such as eggs or fish from sticking to the cooking surface.

Cleaning Instructions

First Time Use

1. Wash grids by hand with water and mild dish soap to remove any residue from the manufacturing process.
2. Rinse thoroughly with hot water and dry completely with a soft cloth.

Griddle Plate

- Clean the griddle after each use while it's still warm.
- Avoid using soap, as it can strip the seasoning layer.
- Remove food debris by scraping it into the grease chute with a spatula or griddle scraper.
- For heavy residue, use a scouring pad with warm water or a food-safe griddle cleaner.
- Loosen stubborn buildup by applying a small amount of water before scraping.
- Always wipe in the direction of the grain to prevent surface damage.
- Once dry, apply a thin, even coat of high smoke point vegetable oil to maintain seasoning.
- Discoloration from high cooking temperatures is normal and does not affect performance.

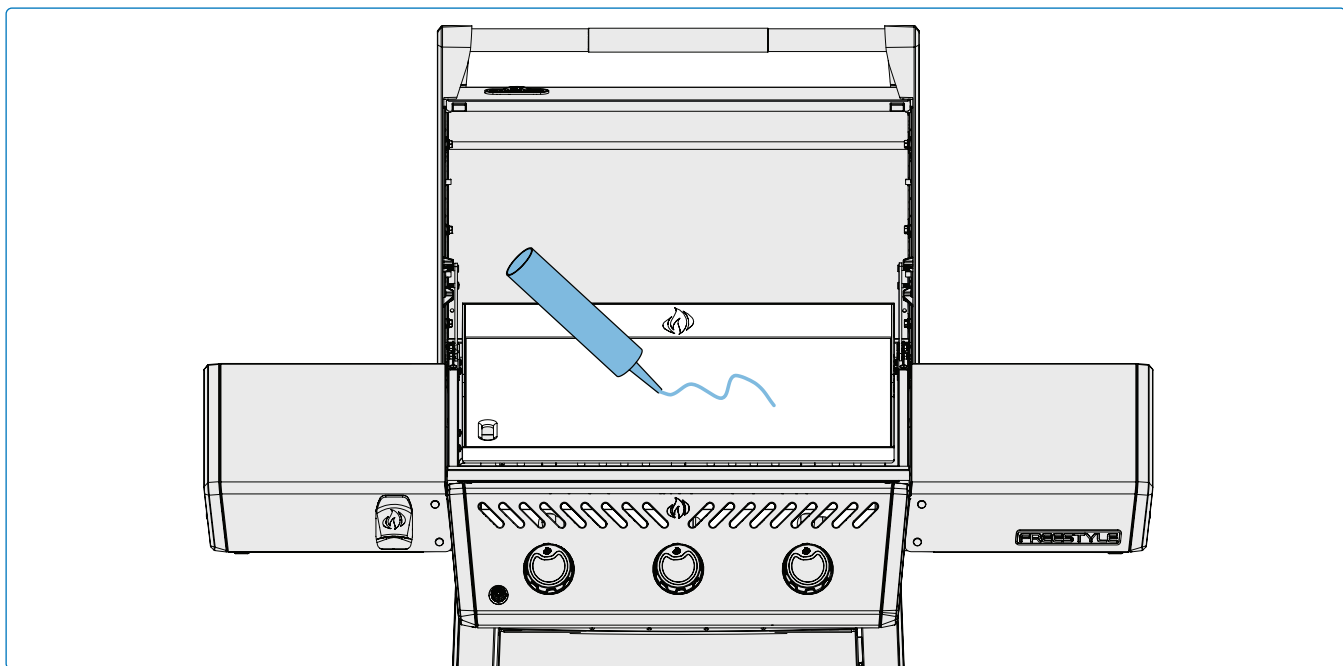

DANGER!

- Always wear protective gloves and safety glasses when cleaning your griddle.
- Accumulated grease is a fire hazard.

Drip Tray

Clean the drip tray after each use.

1. Once the appliance has cooled completely, carefully remove the drip tray straight out from the appliance cart without tilting. **(Fig. 11)**.
2. Clean the tray with hot soapy water. If using chemicals, be sure to carefully follow the manufacturer's instructions to avoid damaging the stainless steel.
3. Fully insert the drip tray back into the appliance.



NOTE:

Tilting the drip tray may cause oil or debris to enter the interior of the appliance.

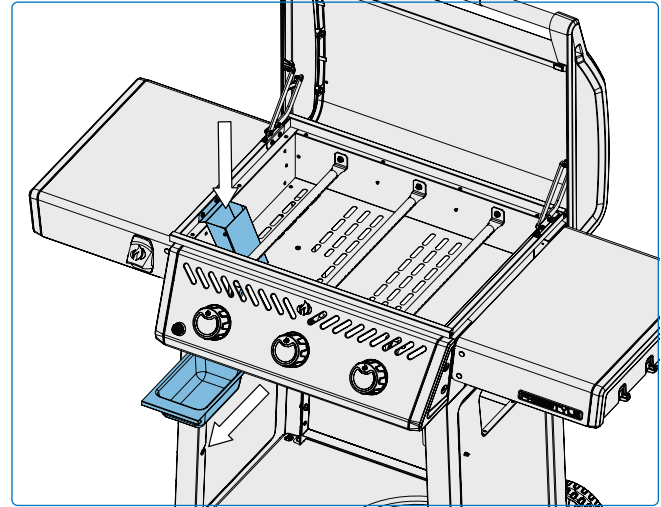

Fig. 11

Grease Chute

Clean the grease chute every 6-8 uses.

1. Once the appliance has cooled completely, remove the griddle plate to access the grease chute (metal channel) underneath.
2. Remove the two fasteners to detach the chute.
3. Use a scraper or nylon grill brush to remove any grease and debris from the inside of the chute. Wipe away any residue with a cloth, or clean in warm soapy water.
4. Reinstall the chute.

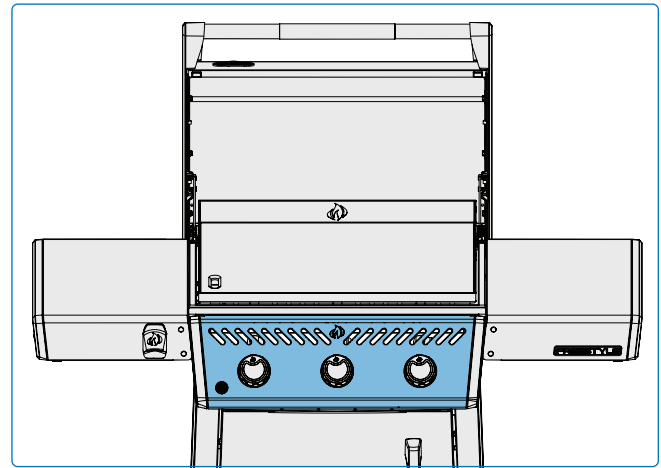

Fig. 12

Control Panel

ONLY use warm soapy water. Text is printed directly on the control panel and will gradually rub off if abrasive or stainless steel cleaners are used. Proper cleaning of the control panel will ensure the text remains contrasting and legible. **(Fig. 12)**.



WARNING!

- Ensure all burners are turned off and griddle is cool before cleaning.
- Do not put griddle plates or any other parts of the griddle in a self-cleaning oven to clean.
- Do not use oven cleaner to clean any part of the appliance.
- Clean the appliance in an area where cleaning solution won't harm decks, lawns, or patios.
- Barbecue sauce and salt can be corrosive and will cause rapid deterioration of the griddle components unless cleaned regularly.

Outside Appliance Surface

- Only use a non-abrasive cleaner. Abrasive cleaners or steel wool will scratch the finish.
- Always wipe in the direction of the grain.
- Handle porcelain enamel components with care. The baked-on enamel finish is glass-like and will chip if struck.
- Stainless steel parts discolour overtime when heated and will turn a golden or brown hue. This is normal and won't affect the performance of the appliance.



NOTE:

Do not use abrasive cleaners or steel wool on any painted, porcelain, or stainless steel parts of your appliance because it will scratch the finish. **(Fig. 13).**

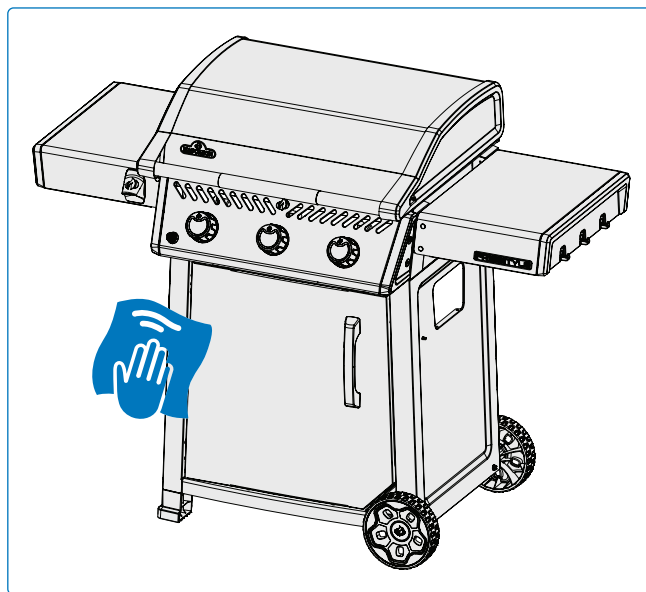

Fig. 13

Insect Screen and Burner Ports

Spiders and insects are attracted to small enclosed spaces. Napoleon has equipped the burner with an insect screen on the air shutter. This reduces the likelihood of insects building nests inside the burner, but doesn't eliminate the problem.

A nest or web can cause the burner flame to burn a soft yellow or orange and cause a fire or backflash at the air shutter underneath the control panel.

1. Remove the griddle plate by lifting it straight up and off.
2. Check the burner ports for blockages: burner ports can close over time because of cooking debris and corrosion.
3. Use an opened paper clip, or the supplied port maintenance bit to clean burner ports.
4. Drill out blocked ports using the supplied drill bit in a small cordless drill: this can be done with the burner attached to the appliance.
5. Do not flex the drill bit when drilling the ports because the drill bit will break.
6. This drill bit is for burner ports NOT for brass orifices that regulate the gas flow to the burner.
7. Do not enlarge the holes.
8. Ensure the insect screen is clean, tight, and free of any lint or other debris.

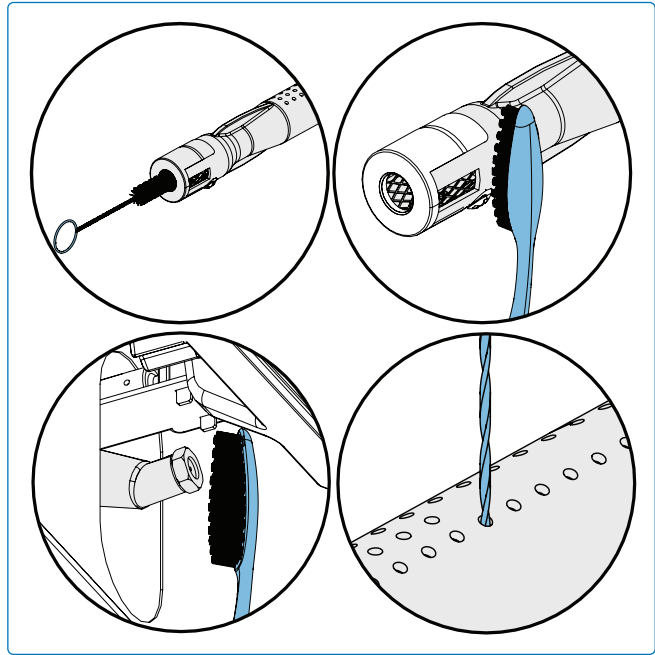

DANGER!

- It is very important the valve/orifice enters the burner tube when reinstalling the burner after cleaning and before lighting your griddle, or a fire or explosion could occur.
- Turn off gas at the source and disconnect the unit before servicing.
- Do not use abrasive cleaners or steel wool on any painted, porcelain, or stainless steel parts of your griddle because it will scratch the finish.
- Avoid unprotected contact with hot surfaces.



SAFETY FIRST!

Always wear protective gloves and safety glasses when servicing your appliance.

Maintenance Instructions

RECOMMENDATIONS

This griddle should be thoroughly inspected and serviced annually by a qualified service person.

- Do not obstruct the flow of ventilation and combustion air.
- Keep the cylinder enclosure ventilation openings located on the side of the cart or enclosure and front and back of the bottom shelf clear from debris.

Combustion in Air Adjustment



IMPORTANT!

- This must be done by a qualified gas installer.

- The air shutter is factory set and should not require adjusting under normal conditions. Adjustments might be required under extreme field conditions.
- The flames of the air shutter will be dark blue, tipped with light blue and occasionally yellow when adjusted correctly.
- Too little air flow to the burner will produce soot and lazy yellow flames.
- Too much air flow to the burner will cause flames to lift erratically and cause igniting difficulties.

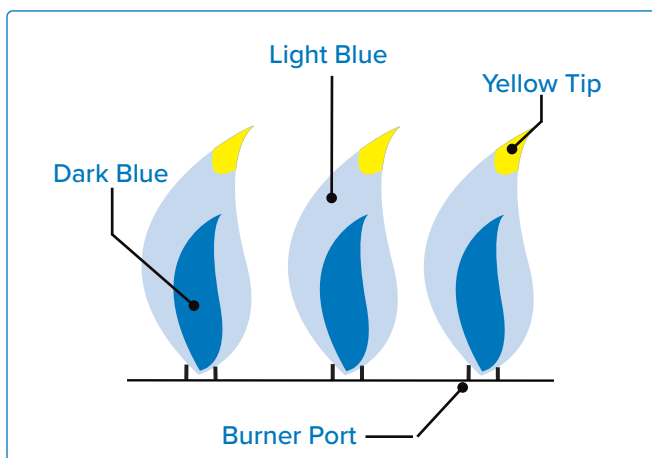

Adjusting the Air Shutter

1. Remove the griddle plate. Leave lid open.
2. You may have to open the cabinet door or remove the top drawer (if equipped) to access the air shutter screw located at the mouth of the burner.
3. Remove the back cover to adjust rear tube burner air shutter.
4. Loosen air shutter lock screw and open or close air shutter as required. **(Table 1)**.
5. Light the burners on high.
6. Visually inspect burner flames.
7. Turn off burners, tighten locking screws, and reinstall parts once shutters are properly adjusted.
8. Ensure insect screens are installed.

Air Shutter Settings	
F24DFP	Main Tube Burner
'3B/P(30)	1 -20.5mm X 3/8" (10mm)
'3+(28-30/37)	1 -20.5mm X 3/8" (10mm)
'3B/P(37)	1 -20.5mm X 3/8" (10mm)
'3B/P(50)	1 -20.5mm X 3/16" (5mm)

Table 1



WE WANT TO HELP!

Contact the Napoleon customer solutions department for recommended replacement parts +31 (0) 88 588 66 55.

Stainless in Harsh Environments

Stainless steel oxidizes or stains in the presence of chlorides and sulfides, especially in coastal regions, warm and highly humid areas, and around pools and hot tubs. These stains look like rust, but they can be easily removed or prevented. Wash stainless and chrome surfaces every 3-4 weeks. Clean with warm soapy water.

Burner Maintenance

- Extreme heat and a corrosive environment can cause surface corrosion to occur even though the burner is made from heavy wall 304 stainless steel.

Avoid Damaging Hot Griddle Surfaces

- Never flood a hot griddle plate with cold water. This can cause warping or damage.
- Never bang or tap metal tools or cookware on the griddle surface.

Clearance Ventilation of Hot Air

- Hot air must have a way to escape the appliance for the burners to function properly.
- The burners can become deprived of oxygen if the hot air is not allowed to escape causing them to backflash.



IMPORTANT!

- Damage resulting from by failure to follow these instructions is **NOT** covered by your griddle warranty.

Restoring Your Griddle

Use these techniques to restore a heavily soiled or moderately rusted griddle.

- Turn all burners to high setting and allow the griddle to heat up for 10-15 minutes.
- Allow to cool completely.
- Use a scraper to loosen all debris and direct it into the grease collection chute. Try scraping at different angles over stubborn spots.
- Apply oil and scrub with a grill brick in circular motions to smooth the surface.
- Wipe clean, then season by applying a thin layer of oil and heating until it burns off.
- Repeat this process two more times.

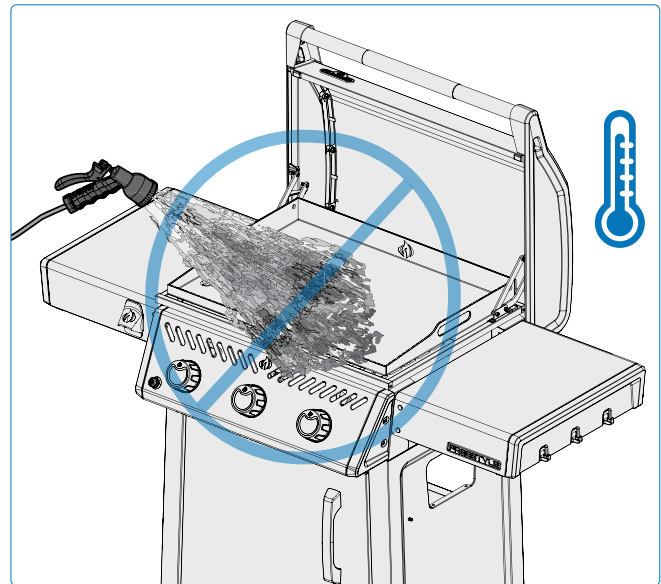

DANGER!

- Turn off gas at the source and disconnect the unit before servicing.
- Maintenance should only be done when the griddle is cool to avoid the possibility of burns.
- A leak test must be performed annually and when any component of the gas train is replaced, or when the smell of gas is present.

Troubleshooting

Lighting Problems

- Burners will not light with the igniter, but will light with a match.
- Burners will not cross light each other.

Possible causes	Solution
Dirty or corroded cross light brackets.	Clean or replace as required.
Lifting flames on burner.	Close air shutter according to “ Maintenance Instructions ” Combustion Air Adjustment section in this Owner’s Manual. IMPORTANT! This must be done by a qualified gas installer.
Loose electrode wire or switch terminal wires.	Check electrode wire is firmly pushed onto the terminal on the back of the igniter. Check the lead wires from the module to the ignition switch (if equipped) are firmly pushed onto their respective terminals.
Dead battery, or installed incorrectly.	Replace with premium heavy- duty battery.



WARNING!

- Keep the griddle away from combustible materials, gasoline, and other flammable vapors and liquids.
- Food particles and grease should not be left on the griddle plate because it attracts rodents which are unsanitary and can chew on wires causing permanent damage to the electrical components.



REGISTER YOUR GRIDDLE!

Go to napoleon.com or your Assembly Guide for replacement parts instructions.



WE WANT TO HELP!

Napoleon is here to ensure your griddling experience is memorable. Contact us if you require additional help.

Noises and Uneven Heat

- Humming regulator.
- Uneven heat.

Possible causes	Solution
Normal humming noise on hot days.	This isn't a defect. It's caused by internal vibrations in the regulator and doesn't affect the performance or safety of the griddle. Humming regulators WILL NOT be replaced.
The cylinder valve was opened too quickly.	Open cylinder valve slowly.
Improper heating.	Preheat the appliance with the burners on high for 10 to 15 minutes.
Excessive grease and ash build-up on drip pan.	Clean drip pan regularly. Do not line pan with aluminum foil. Refer to the " Cleaning Instructions " section.

Peeling Paint

- Paint appears to be peeling.

Possible causes	Solution
Grease build-up on inside surfaces.	This is not a defect. The finish on the lid and hood is porcelain or stainless steel and will not peel. The peeling is caused by hardened grease, which dries into paint-like shards, that flake off. Regular cleaning will prevent this. See " Cleaning instructions " section.

Crowning

- Griddle plate is uneven in the center.

Possible causes	Solution
Thermal expansion.	It is normal for the stainless steel griddle plate to crown (become slightly uneven) a bit in the center. This is caused by the natural contracting and expansion of the metal and is expected in the thermal expansion process that occurs below the griddle plate.

Gas Flow

- Low heat or low flame when valve is turned to high.
- Burners burn with yellow flame, accompanied by the smell of gas.
- Flames lift away from burner, accompanied by the smell of gas, and possible lighting difficulties.
- Burner output on HIGH, but setting is LOW. Rumbling noise and fluttering blue flame at burner surface.

Possible causes	Solution
Propane – improper lighting procedure.	Ensure lighting procedure is followed carefully. All gas valves must be in the OFF position when the tank valve is turned on. Turn tank on slowly to allow pressure to equalize. See Operation – "Lighting Instructions" section.
Weld failure in the burner housing.	Allow burner to cool and inspect very closely for cracks. Contact your authorized Napoleon dealer to order replacement burner assembly if any cracks are found.
Possible spider web or other debris.	Thoroughly clean nest or webs out of your burner orifice by removing it and following instructions in this manual. See "Cleaning Instructions" section.
Improper air shutter adjustment.	Open or close air shutter slightly according to this manual. See "Maintenance Instructions" section. IMPORTANT! This must be done by a qualified gas installer.
Lack of gas.	Check gas level in propane cylinder.
Supply hose is pinched.	Reposition supply hose as necessary.
Propane regulator in low flow state.	Turn the burners off and close the tank valve, wait 5 minutes before fully re-opening the valve, allow a few seconds for the pressure to equalize before following the Lighting Instructions to start the griddle. Ensure igniting procedure is followed carefully every time you cook. All gas valves must be OFF when the tank valve is turned on. Always open the tank valve slowly.

NAPOLEON PRODUCT WARRANTY



FOR FREESTYLE AND TRAVELQ™ 285 SERIES (INCLUDING PRO285) 10 Year Napoleon Gas Grills Limited Warranty

NAPOLEON warrants that the components of your new NAPOLEON product will be free from defects in materials and workmanship from the date of purchase for a period of:

Aluminum castings/stainless steel base	10 years
Stainless steel lid	10 years
Porcelain-enameled lid	10 years
Painted steel lid	5 years ^{plus 10}
Stainless steel tube burner	5 years ^{plus 10}
Stainless steel flame protection inserts	5 years ^{plus 10}
Porcelainized cast iron cooking grids	5 years ^{plus 10}
Ceramic infrared burner (excluding mesh)	5 years ^{plus 10}
Porcelain flame protection inserts	3 years ^{plus 10}
All other parts	2 years

Plus 1d: refers to an extended warranty period, during which we supply spare parts to the purchaser at 50% of the current retail price for the lifetime* of the grill.

Plus 15: refers to an extended warranty period, during which we supply spare parts to the purchaser at 50% of the current retail price for an additional 15 years.

Plus 10: refers to an extended warranty period, during which we supply spare part to the purchaser at 50% of the current retail price for an additional 10 years.

***Lifetime** refers to a warranty period of 30 years.

This warranty is valid in: the European Union, Switzerland, Andorra, San Marino, Norway, Iceland and Liechtenstein.

The customer's legal entitlements in the event of defects in accordance with WKRL - (EU) 2019/711) are not affected, restricted or altered by the present warranty. The exercise of statutory entitlements is to take place free of charge.

WARRANTY CONDITIONS AND LIMITATIONS

NAPOLEON guarantees that its products are free from defects exclusively to the original purchaser, and only insofar as the purchase took place through an official NAPOLEON dealer. The following conditions and restrictions apply:

The present manufacturer's warranty is not transferable nor viable for extension under any circumstances or by any of our representatives.

The gas grill must be installed by a licensed, authorized service technician or contractor.

Installation must take place in accordance with the installation instructions provided, as well as all local and national building and fire codes.

This limited warranty does not cover damage caused by improper operation, lack of maintenance, grease fire, environmental exposure, accidents, modification, abuse, or neglect.

The installation of spare parts from other manufacturers voids the present warranty. The discoloration of plastic elements due to the

application of chemical cleaning agents or exposure to sunlight is not covered under this warranty.

This warranty also excludes any of the following: Scratches, dents, paint defects, coatings, corrosion or discoloration caused by exposure to heat or abrasive and chemical cleaners, as well as chips to porcelain-coated parts and any components used in the installation of the gas grill.

If a part deteriorates to the point where it becomes inoperable (due to rusting or burning through) within the warranty period, the customer will be issued with a replacement part.

After the first year, NAPOLEON has the authority under this warranty (President's Limited Lifetime Warranty, 15 Year Limited Warranty, 10 Year Limited Warranty, 3 Year Limited Warranty) to waive any warranty obligation at its free discretion by refunding the original purchaser to the tune of the wholesale price of the relevant defective warranty parts.

NAPOLEON accepts no responsibility for any installation, labor hours or other costs or expenses associated with the reinstallation of a warranty part. Costs of this nature are not covered by the present warranty.

Notwithstanding any regulations under this warranty (President's Limited Lifetime Warranty, 15 Year Limited Warranty, 10 Year Limited Warranty, 3 Year Limited Warranty), NAPOLEON's liability under this warranty is defined by the foregoing, and does not cover any incidental, consequential, or indirect damage in any case whatsoever.

GUARANTOR:

NAPOLEON EUROPE | WOLF STEEL EUROPE B.V.
De Riemsdijk 22 | 4004LC | Tiel | Gelderland Netherlands

+31 (0) 88 588 66 55

eu.info@napoleon.com

This warranty defines NAPOLEON's duties and liability with respect to the NAPOLEON gas grill. NAPOLEON assumes no further liability in connection with the sale of this product, nor does it authorize any third party to assume any other liability on its behalf.

NAPOLEON assumes no responsibility for: Overheating, extinguishing of the flame by environmental factors such as strong winds or inadequate ventilation.

NAPOLEON does not accept liability for any damage to the gas grill caused by the weather, hail, rough handling, aggressive chemicals or cleaning agents.

Warranty claims must be accompanied by the proof of purchase or a copy thereof stating the serial and model number.

NAPOLEON reserves the right to have the product or any part thereof inspected by one of its representatives prior to the fulfilment of any warranty obligation.

NAPOLEON does not bear shipping costs, labor hours or export duties.

NAPOLEON®

CELEBRATING OVER 40 YEARS
OF DELIVERING HOME COMFORT PRODUCTS



NAPOLEON® products are protected by one or more U.S. and Canadian and/or foreign patents or patents pending.



Address

Wolf Steel Ltd.

De Riemsdijk 22, 4004 LC,
Tiel, The Netherlands
10-12 Home Farm,
Meriden Road, Berkswell,
CV7 7SL, United Kingdom
24 Napoleon Road, Barrie,
Ontario, L4M 0G8, Canada



Phone

Europe

+31 (0) 88 588 66 55

Online

✉ eu.info@napoleon.com

🌐 www.napoleon.com



N415-0824CE-GB