







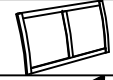

# ASSEMBLY INSTRUCTIONS

**B0182-115 BALLARD 6/6 - 6/0 EK/WK HEADBOARD , FOOTBOARD & SLAT KIT**



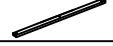



**B0182-335 BALLARD 6/6 & 5/0 EK/Q PANEL SIDE RAILS**

Thank you for purchasing this quality product. Be sure to check all packing materials carefully for small parts, which may have come loose inside the carton during shipment. Identify and count all items and compare with the parts list and/or hardware list shown.

### PARTS LIST

| NO | COMPONENT                              | DRAWING   | QTY   |
|----|--|---|-------|
| A  | Headboard                              |  | 1 pc  |
| B  | Footboard                              |  | 1 pc  |
| C  | Right Side Facing (RSF ) Headboard Leg |  | 1 pc  |
| D  | Left Side Facing (LSF) Headboard Leg   |  | 1 pc  |
| E  | Slat                                   |  | 4 pcs |
| F  | Slat Support Leg                       |  | 8 pcs |
| G  | Rail                                   |  | 2 pcs |
| H  | Headboard Stretcher                    |  | 1 pc  |

### HARDWARE LIST

| PACKED INSIDE HEADBOARD |                               |   |       |
|-------------------------|-------------------------------|---|-------|
| NO                      | COMPONENT                     | DRAWING   | QTY   |
| 1                       | Bolt M6 x 1 3/8"              |  | 6 pcs |
| 2                       | Spring Washer 1/4"            |  | 6 pcs |
| 3                       | Flat Washer 1/4" ID x 1/2" OD |  | 6 pcs |
| 4                       | Allen Key M4 x 2 9/16"        |  | 1 pc  |
| 5                       | Allen Key M5 x 2 9/16"        |  | 1 pc  |
| 6                       | Flat Head Screw M4 x 1 1/4"   |  | 8 pcs |

WEIGHT CAPACITY

800 LBS

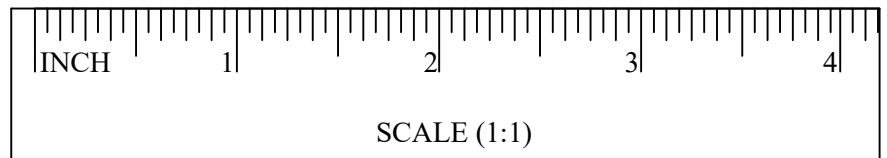

**STEP 1** : Assemble the Headboard Legs (C & D) to the Headboard (A) by using the Allen Key (4) with hardware 1, 2, and 3.

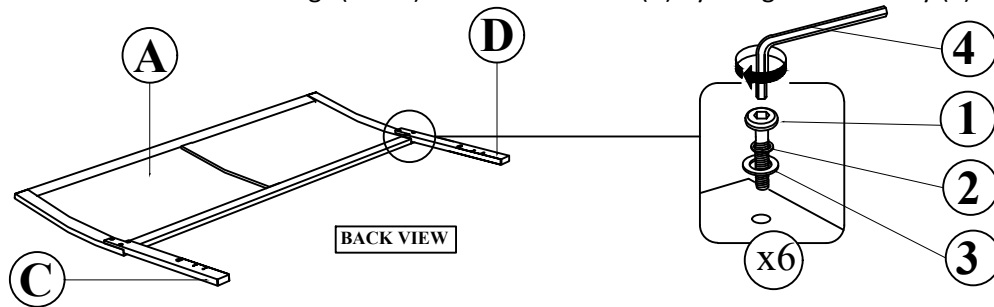

**STEP 2** : Assemble the Headboard Stretcher (H) to Headboard Legs (C & D) by using a screwdriver with hardware (6).

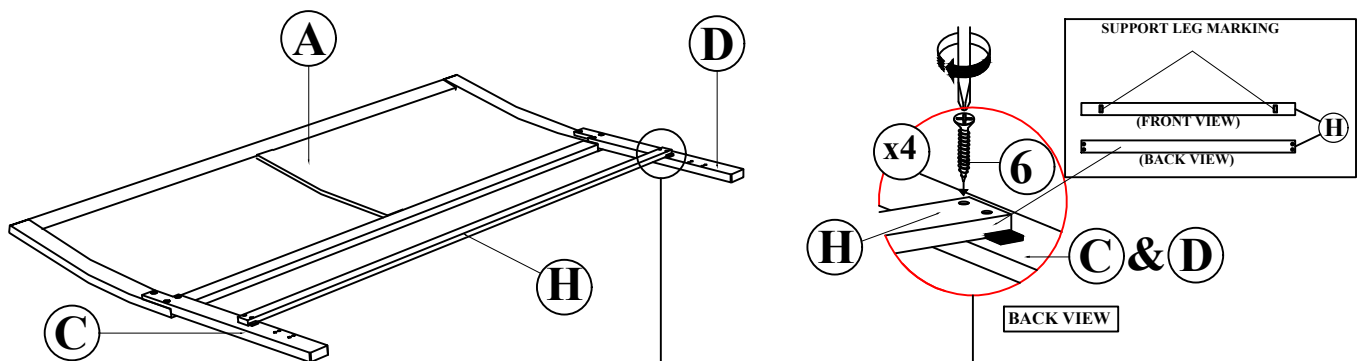

**STEP 3 :** Loosen the bolts on the Headboard Legs (C & D) and the Footboard (B) by using ALLEN KEY (5). Hook the Capped Rails(G) to the Headboard Legs (C & D) and the Footboard (B), and push the bracket firmly into place then tighten the bolts.

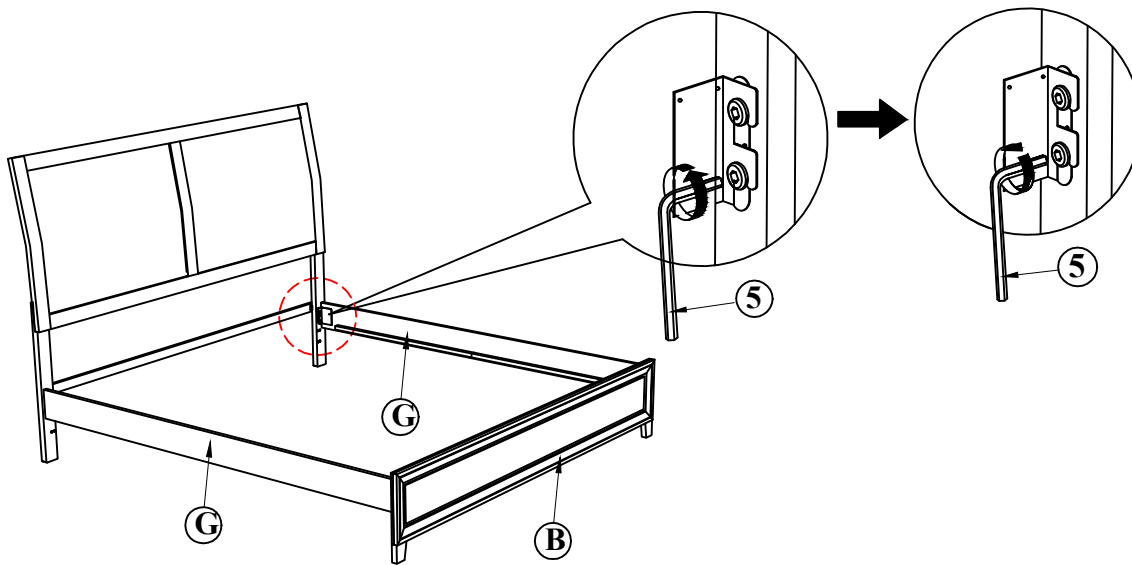

**STEP 4 :** Assemble the Bed Slat Support Legs (F) to the Slats (E)

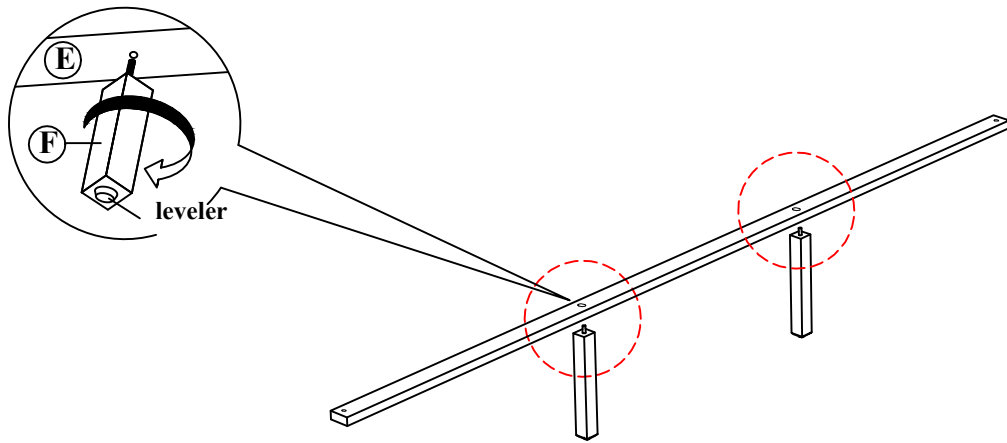

**STEP 5 :** Assemble the Slats (E) to Capped Rails (G) by using a screwdriver with hardware 6. Adjust the leveler on the Bed Slat Support Legs (F) to level the bed.

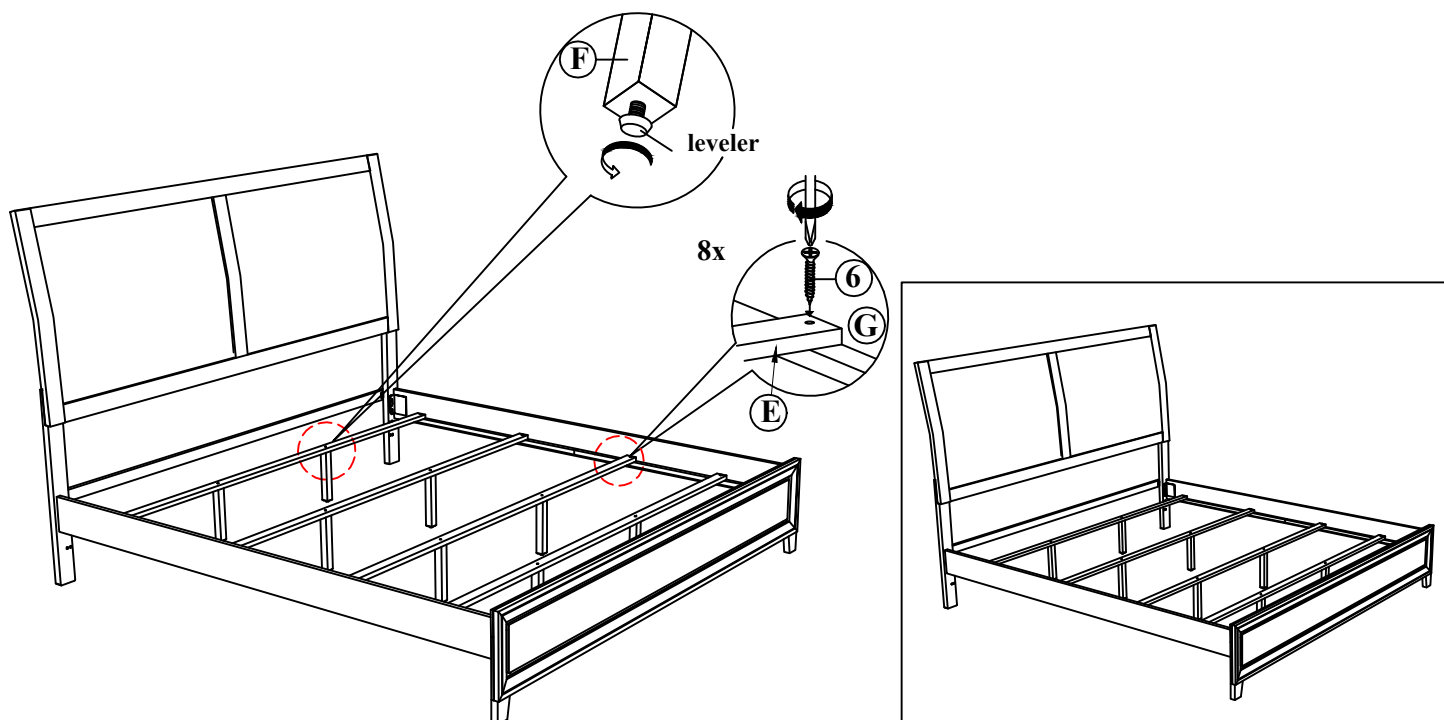

NOTE : MUST TIGHTEN SCREWS PERIODCALLY WITH USE SCREW WILL BECOME LOOSE CHECK TIGHTNESS OF ALL SCREW EVERY 6-8 WEEKS.