

WALKER EDISONTM

Annette Contemporary Curved Headboard Bed Frame Queen

SKU# WEANN03QB1

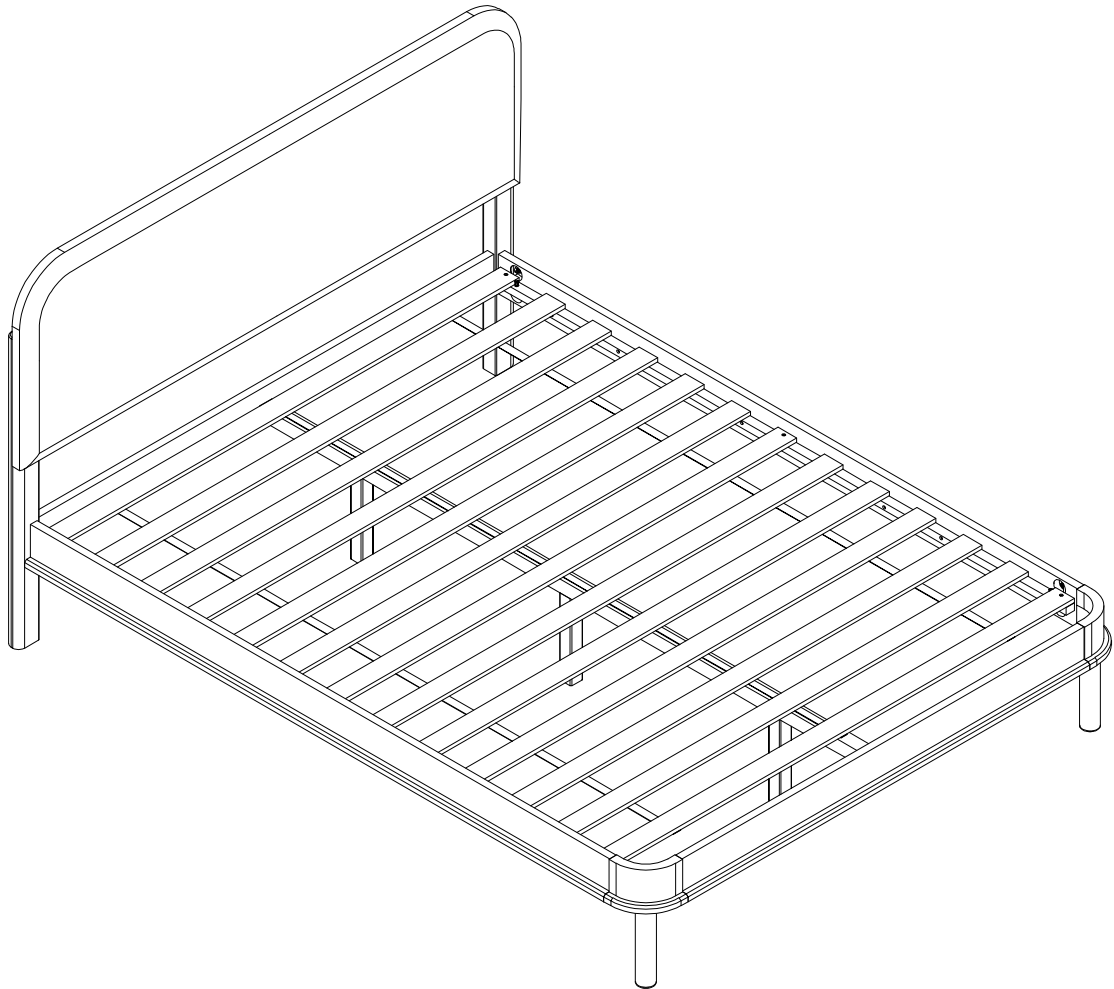

For Residential Use Only

Please visit our website for the most current instructions, assembly tips, report damage, or request parts. www.walkeredison.com



Time to get started

Set up a clean and soft workplace to get started and avoid damage during the assembly. It also helps to double-check that you've got all the pieces and parts before diving in to assembly.

Estimated time for assembly

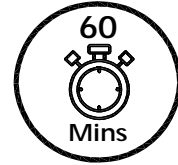

People recommended for assembly

Make it a team effort! Grab a friend for quicker, easier assembly.

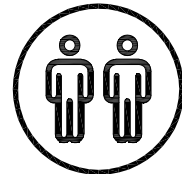

2 People Build

Tools Needed

Grab a Phillips head screwdriver to conquer this assembly

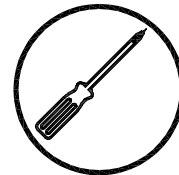

Use power tools with caution

You can cause cracking or damage to the material and easily strip the hardware. If you choose to use a power tool, your product will no longer be covered under Walker Edison's warranty.

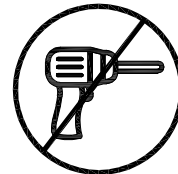

Scan to get assembly tips and help!







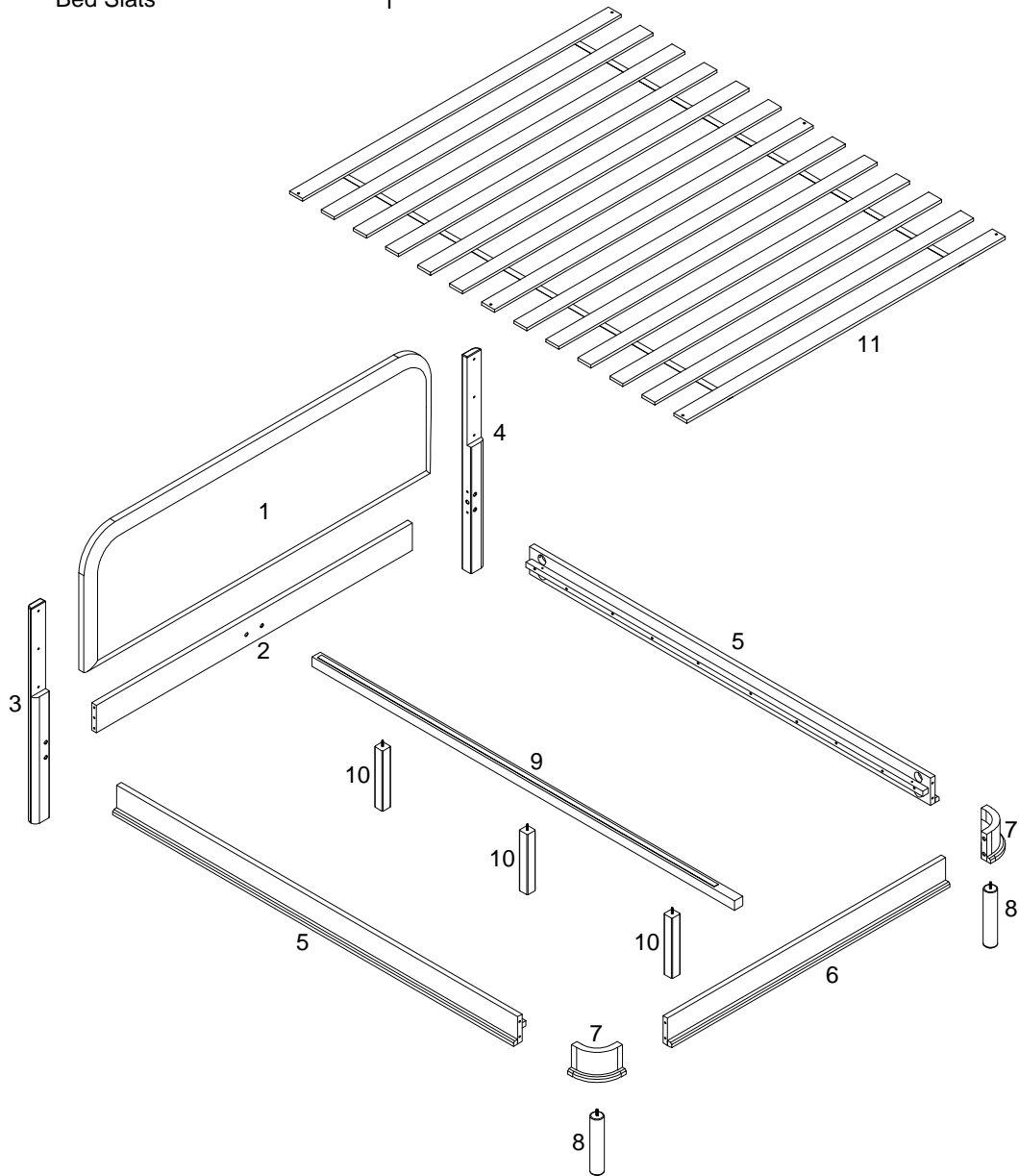





Parts List

Part Number	Description	Quantity
1	Headboard	1
2	Headboard Support Rail	1
3	Left Headboard Post	1
4	Right Headboard Post	1
5	Side Rails	2
6	Bottom Rail	1
7	Curved Corner Pieces	2
8	Legs	2
9	Center Support Rail	1
10	Middle Support Legs	3
11	Bed Slats	1



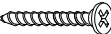

Hardware List

Part	Size	Name	Quantity
A	 Ø8x30mm	Wooden dowel	8
B	 Ø5/16"x16x1.2mm	Washer	10
C	 Ø5/16"x20mm	Bolt	4
D	 Ø5/16"x38mm	Bolt	6
E	 M4	Hex key	1
F	 Ø5/16"x80mm	Bolt	14
G	 Ø5/16"	Half - moon washer	14
H	 Ø5/16"	Nut	14
J		Wrench	1
K	 105x40x32mm	U Bracket	2
L	 Ø3x15mm	Screw	4
M	 Ø4x30mm	Screw	6

*The hardware quantities listed above are required for proper assembly.
Extra hardware pieces may be included.*

Step 1

Let's get started! First, insert the Wooden dowels (A) into both ends of the Headboard Support Rail (2).

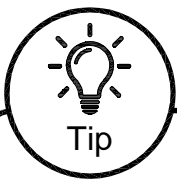
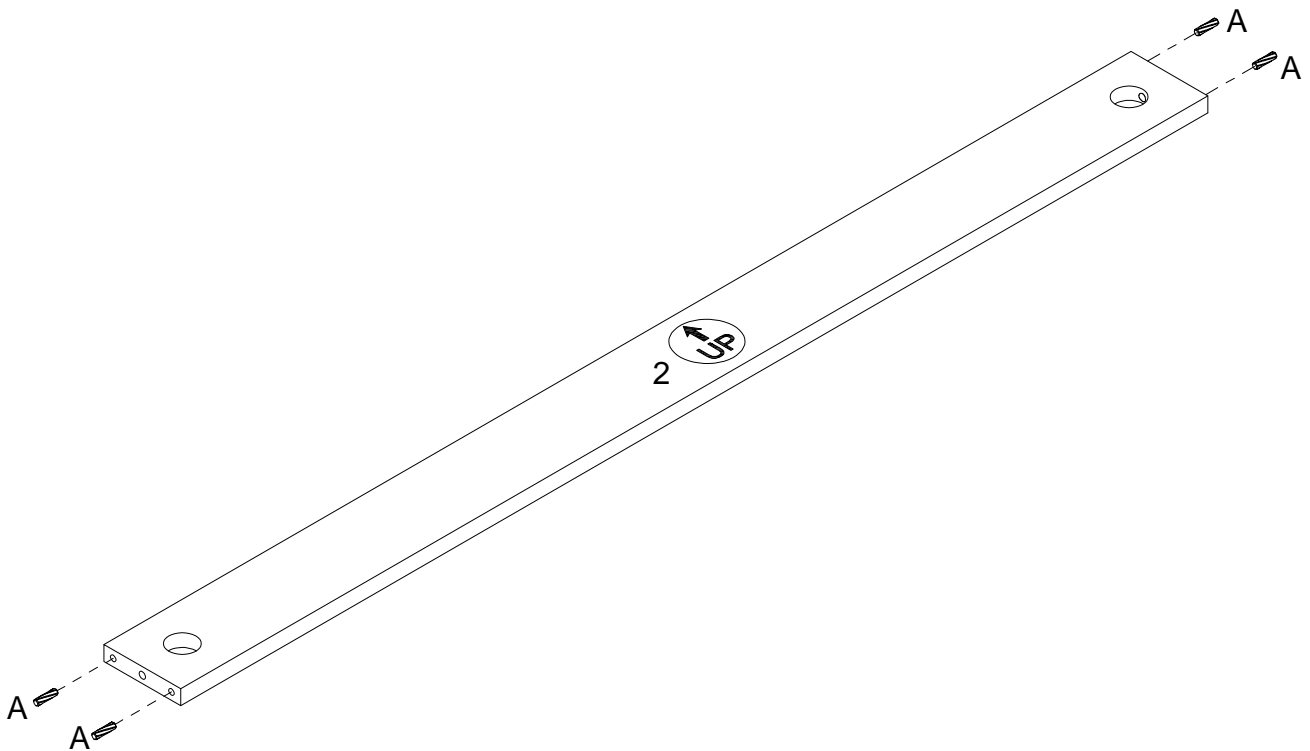

Wood Dowels

Dowels are essential in furniture assembly for creating strong, precise connections.

They ensure structural integrity, prevent shifting, and simplify alignment, resulting in sturdier, longer-lasting furniture.

Follow these steps:

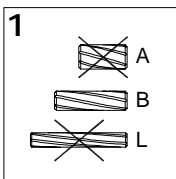

1: Select appropriate size dowel compared to size of drill hole and alignment in instructions. If unsure of placement place dowel next to drill hole to compare size and ensure correct placement.

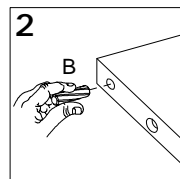

2: Insert into drill hole and press firmly to ensure placement is set.

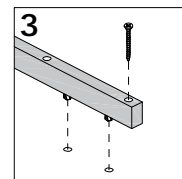

3: Align the dowel with corresponding piece and press together until secure.

Step 2

Next you will hand tighten the Bolts (F) into the Left and Right Headboard Posts (3 & 4).

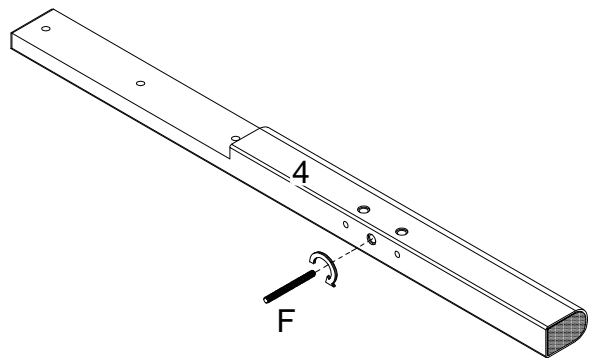
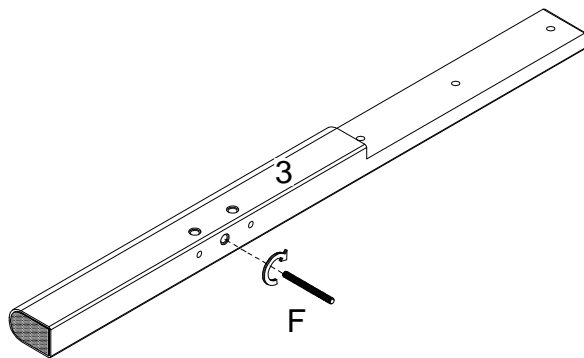

Step 3

Turn over the Headboard Posts (3 & 4) and insert the bolts into to the Headboard Support Rail (2). Secure with a Half-moon washer (G) and Nut (H) then tighten with the Wrench (J).

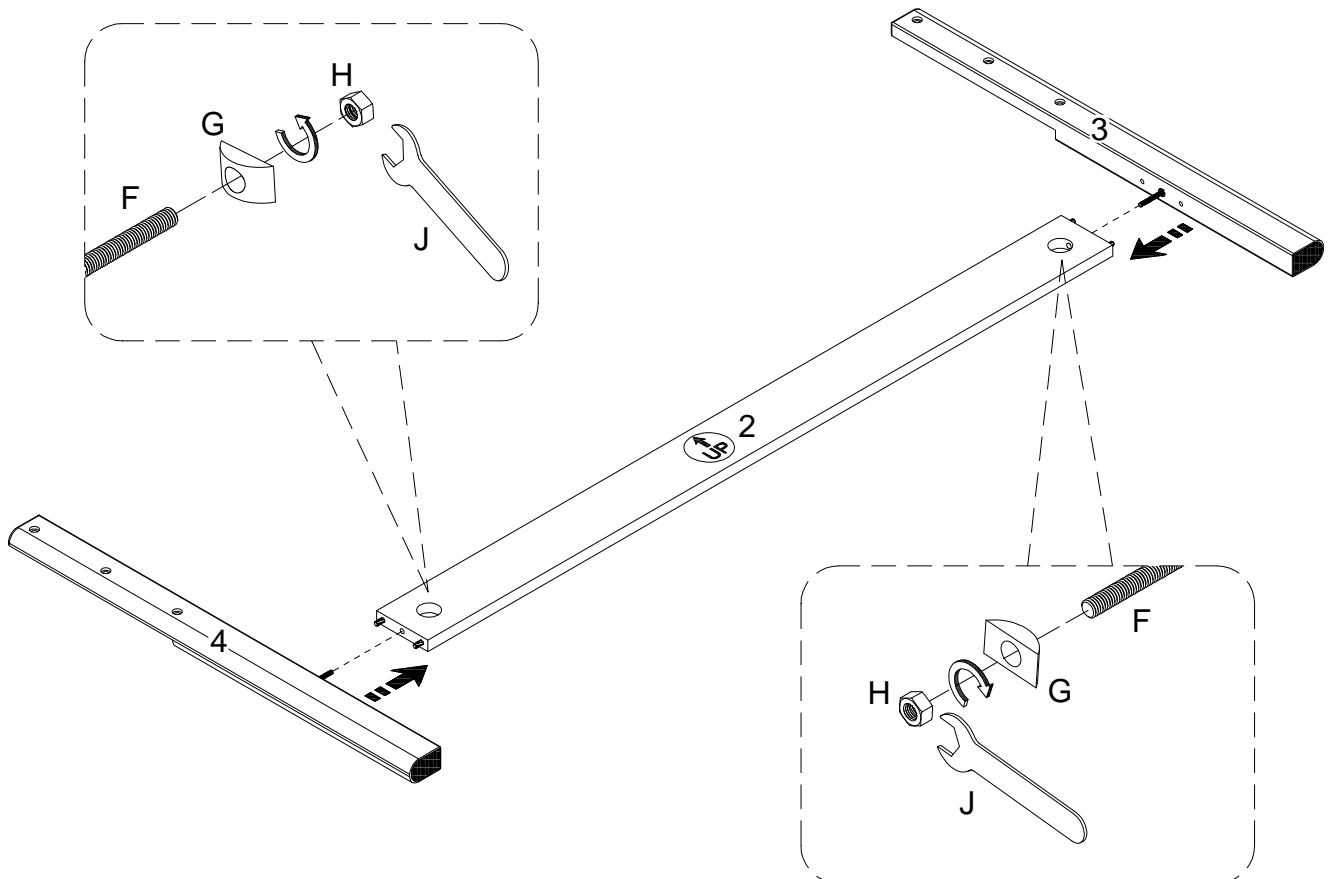

Step 4

Now let's attach this structure to the Headboard (1) using our Flat washers (B) and Bolts (D). Be sure to tighten completely with the Hex key (E).

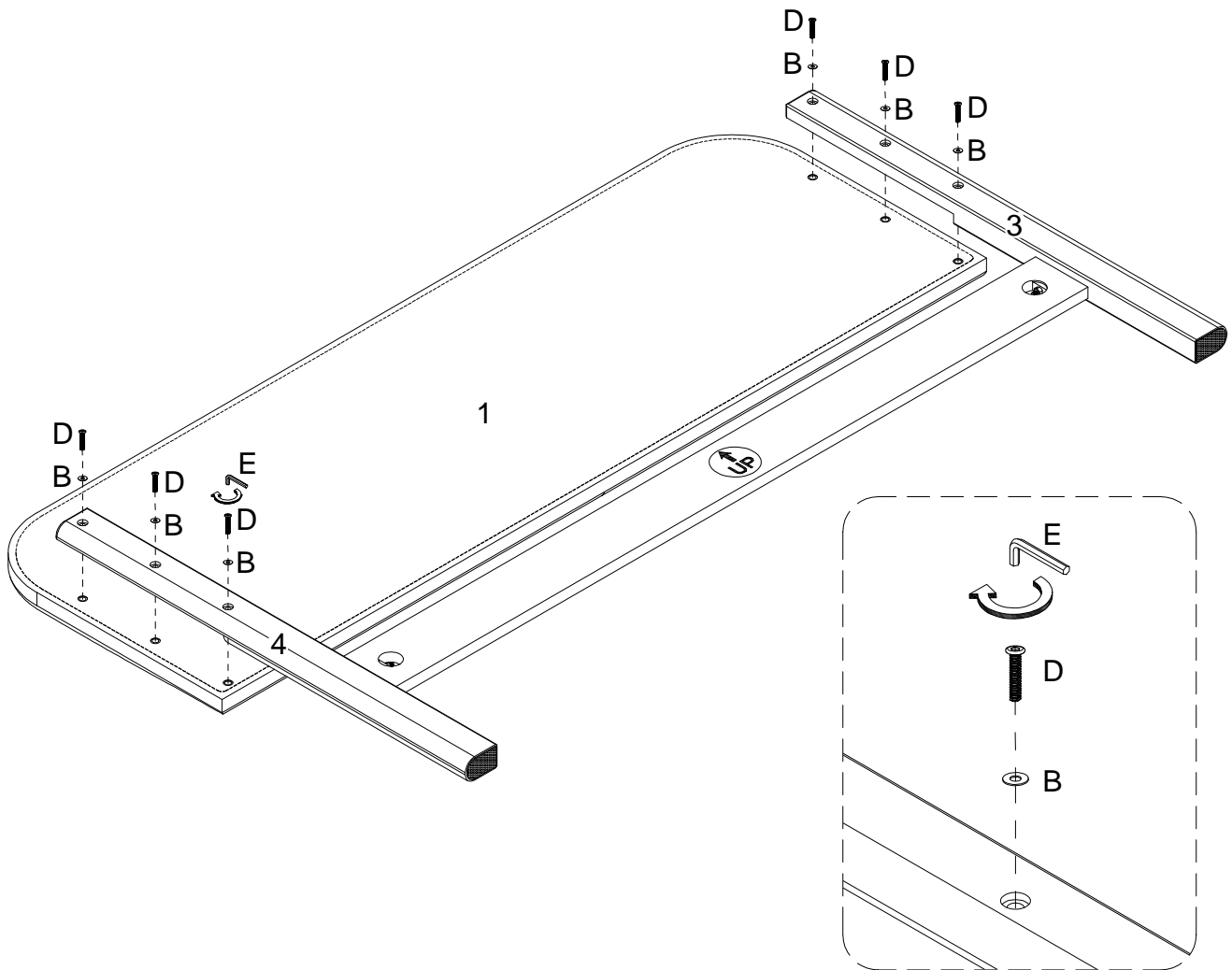

Step 5

Turn over the headboard and screw in one of U brackets (K) to the Headboard Support Rail (2) using the Flat washers (B) and Bolts (C).

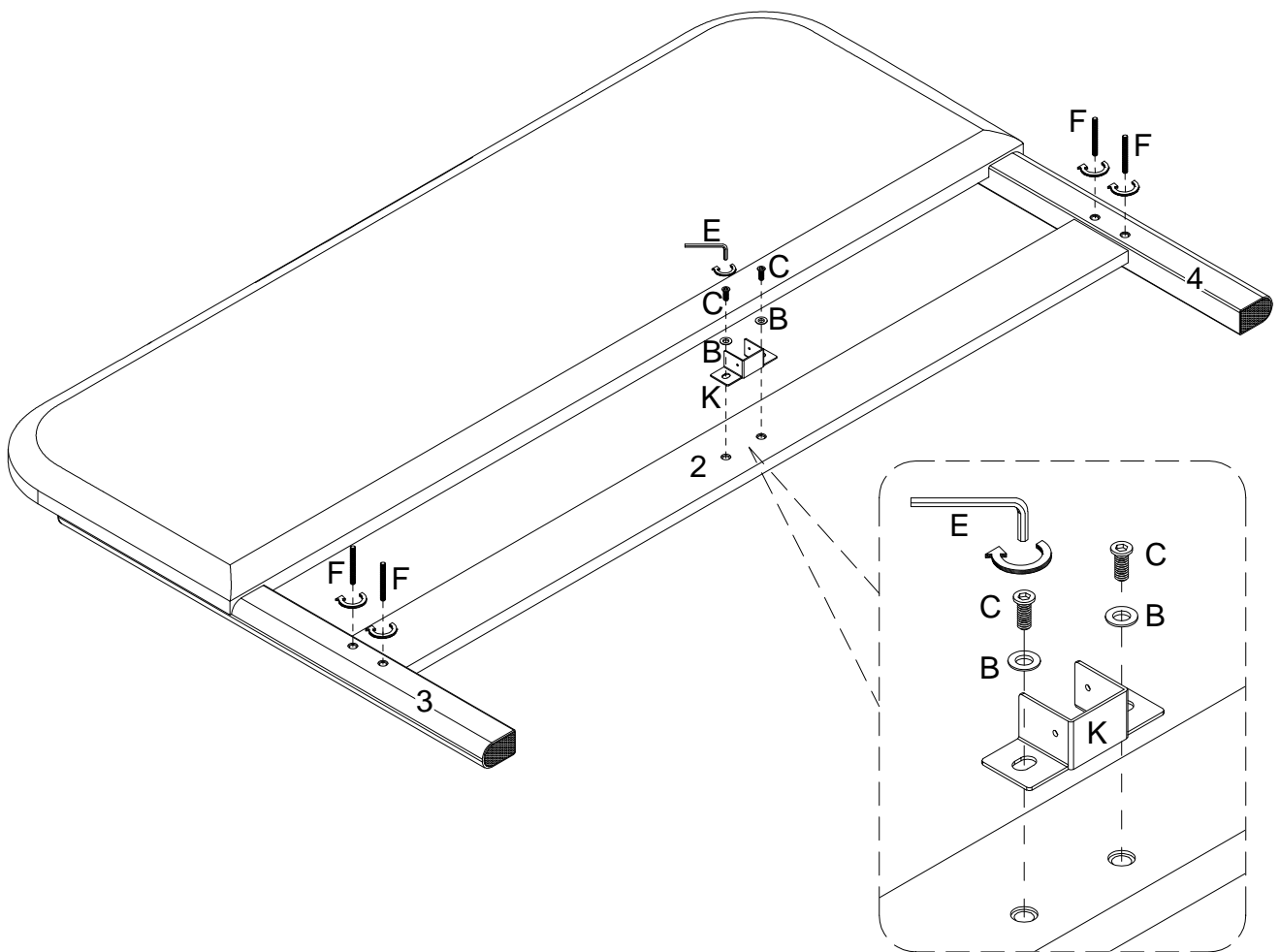

Step 6

Attach the other U bracket (K) to the Bottom Rail (6) using the using the same Flat washers (B) and Bolts (C).

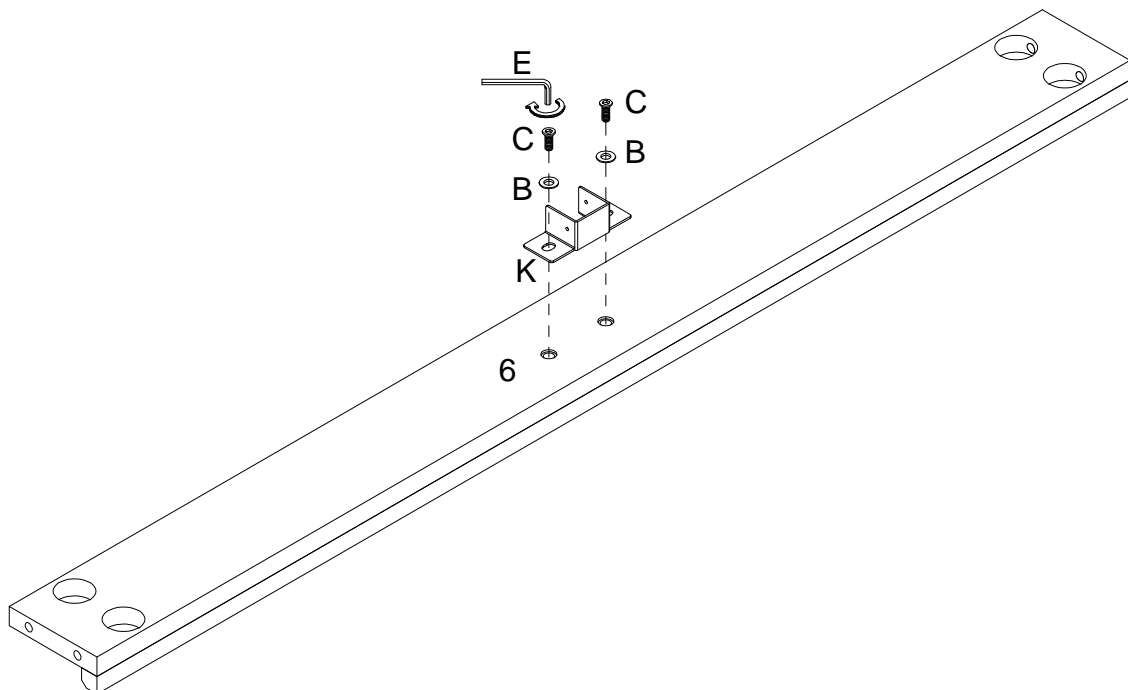

Step 7

Now, grab eight Bolts (F) and hand tighten them into both of the Curved Corner Pieces (7).

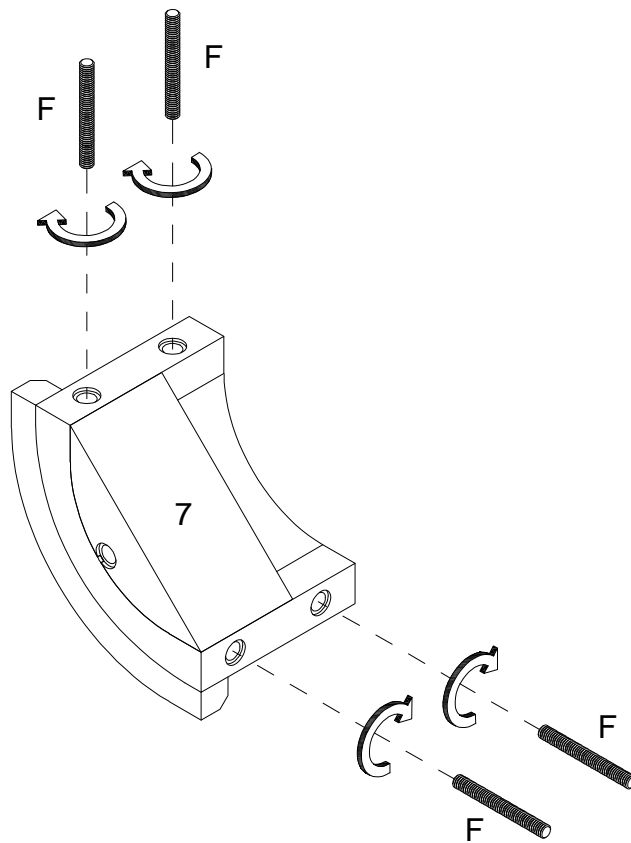

x 2

Step 8

After removing the plastic caps on the Legs (8), twist them into the bottom of the Curved Corner Pieces (7) until tight.

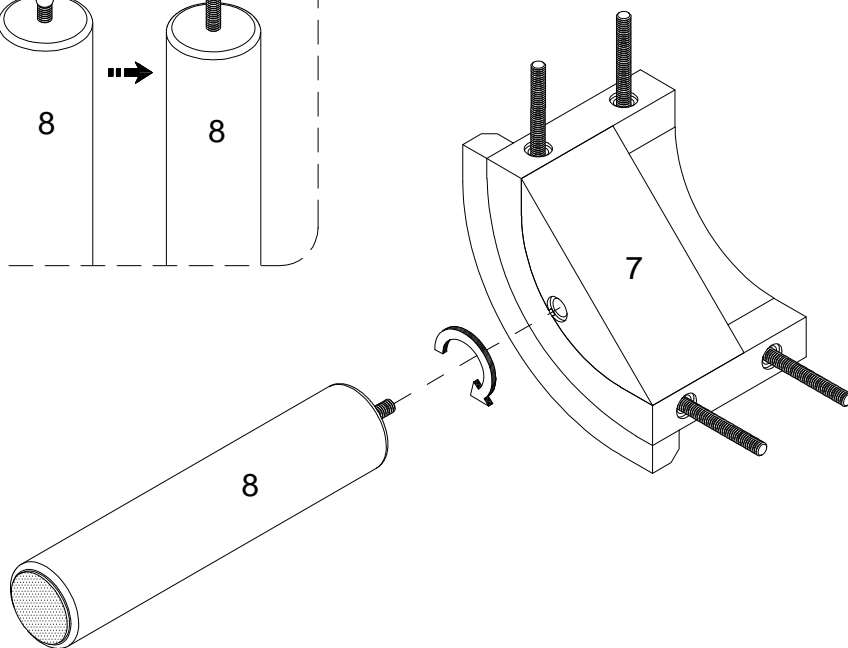
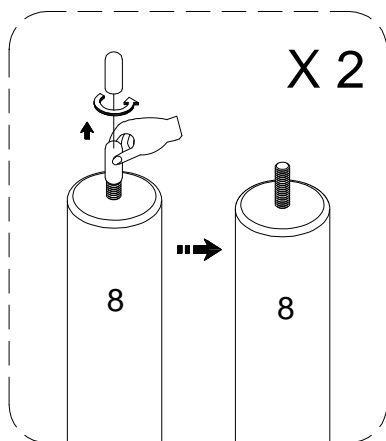

x 2

Step 9

Remember how we put the Headboard together? Follow that same process and attach the Curved Corner Pieces (7) to each side of the Bottom Rail (6) using the Half-moon washers (G) and Nuts (H) tightening with the Wrench (J).

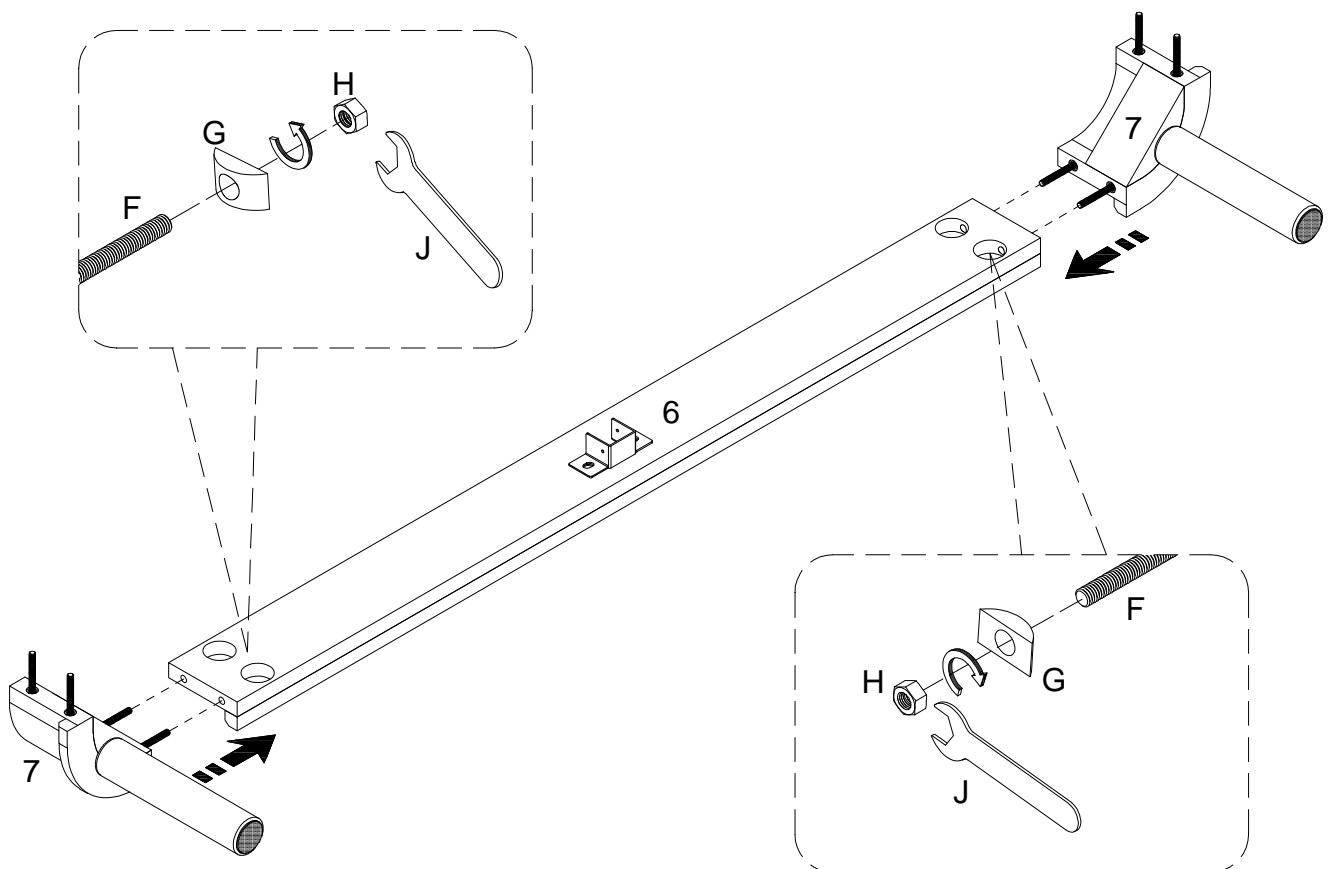

Step 10

Find some yoga blocks, books, or anything you have near you to prop up the Side Rails (5) while attaching them to the Headboard posts (3 & 4) with the Half-moon washers (G) and Nuts (H).

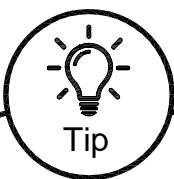
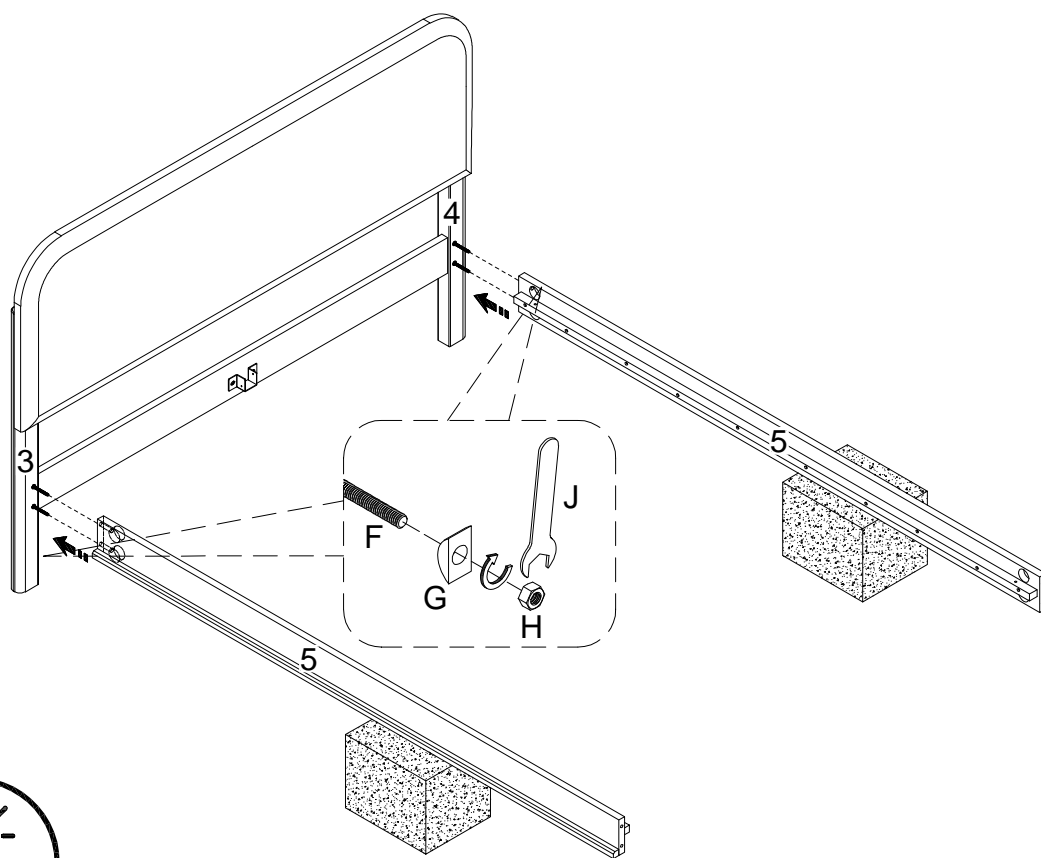

Tip

Find some yoga blocks, books, or anything you have near you to prop up the Side Rails (5) while attaching them to the Headboard posts (3 & 4) with the Half-moon washers (G) and Nuts (H).

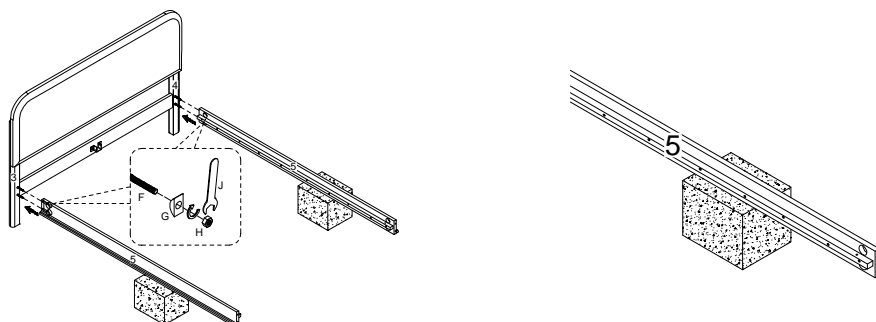

Step 11

Repeat that same process to finish off the frame. Place the bolts in the Curved Corner Pieces (7) into the Side Rails (5) and secure with the Half-moon washers (G) and Nuts (H).

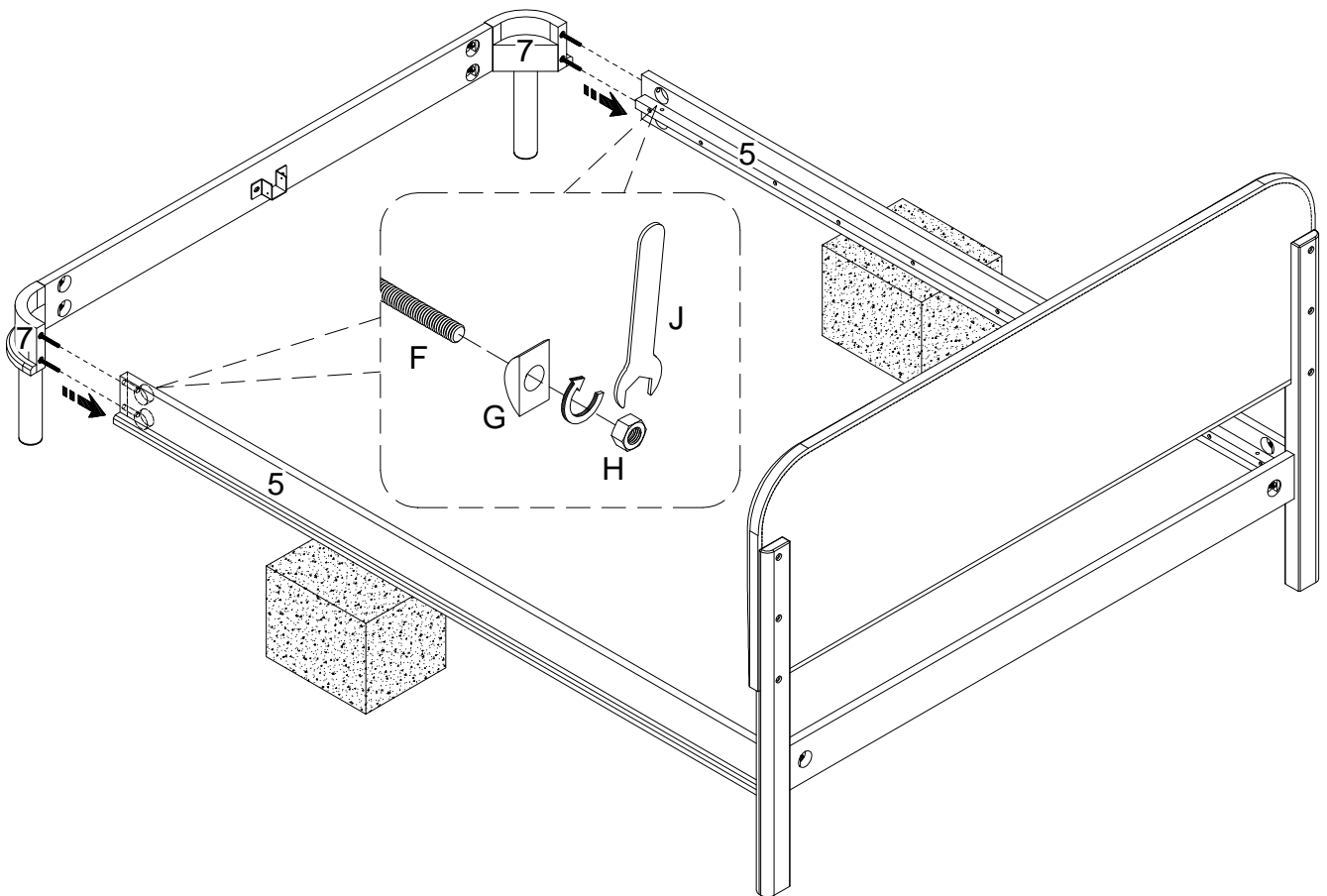

Step 12

We are getting close! Twist off the plastic caps on the Middle Support Legs (10) and then screw them into the Center Support Rail (9).

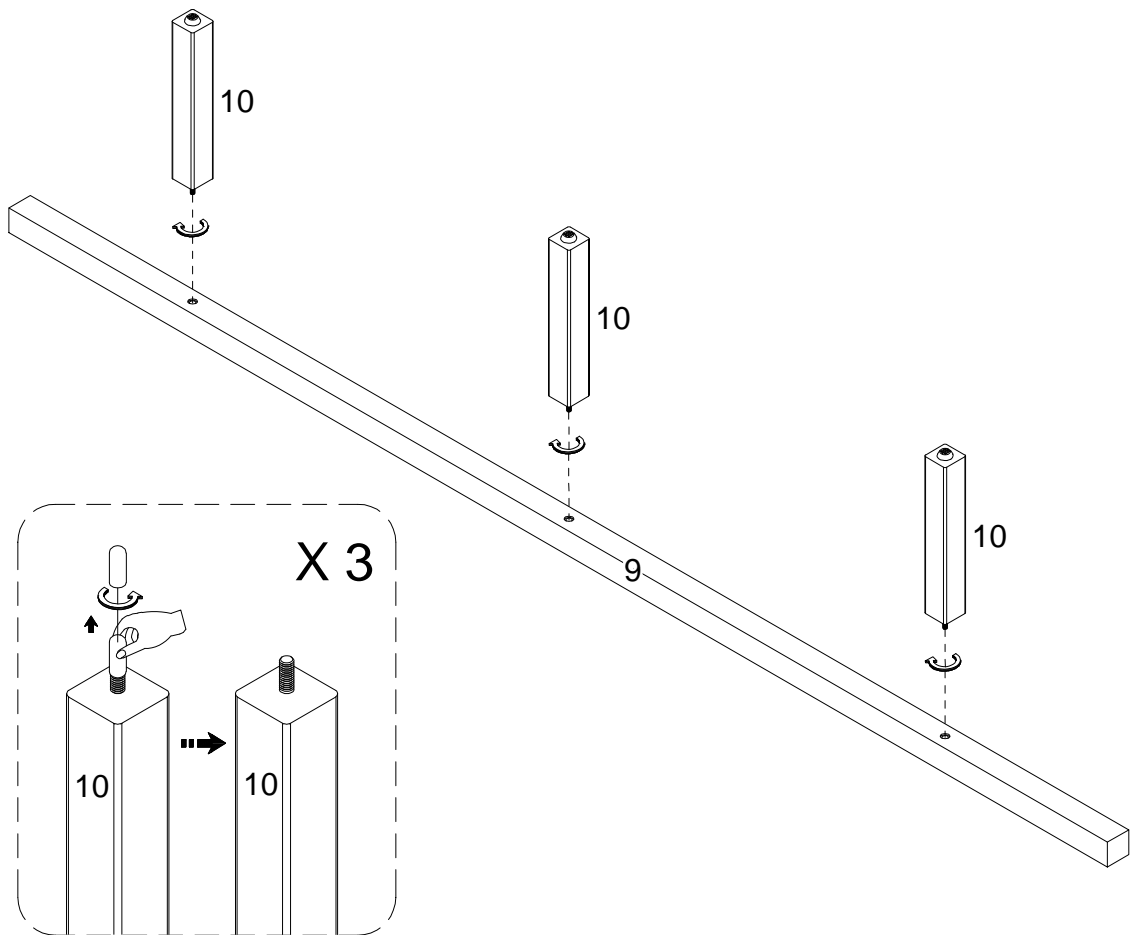

Step 13

Place the Center Support Rail (9) into the U brackets (J) and secure it through the sides with the screws (L).

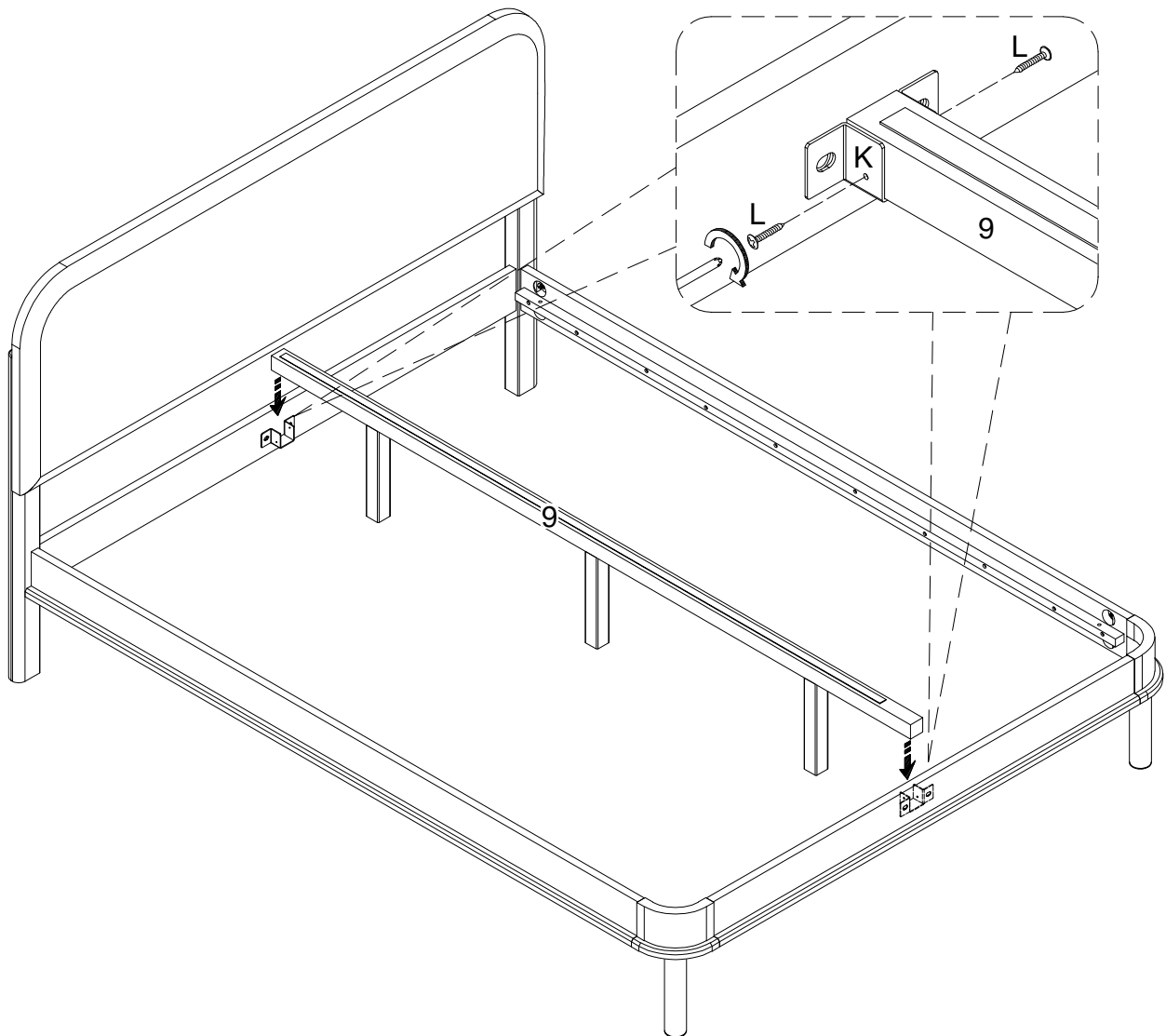

Step 14

Now's the time to make any adjustments to the levelers on the bottoms of the Middle Support Legs (10) before we lay the slats down.

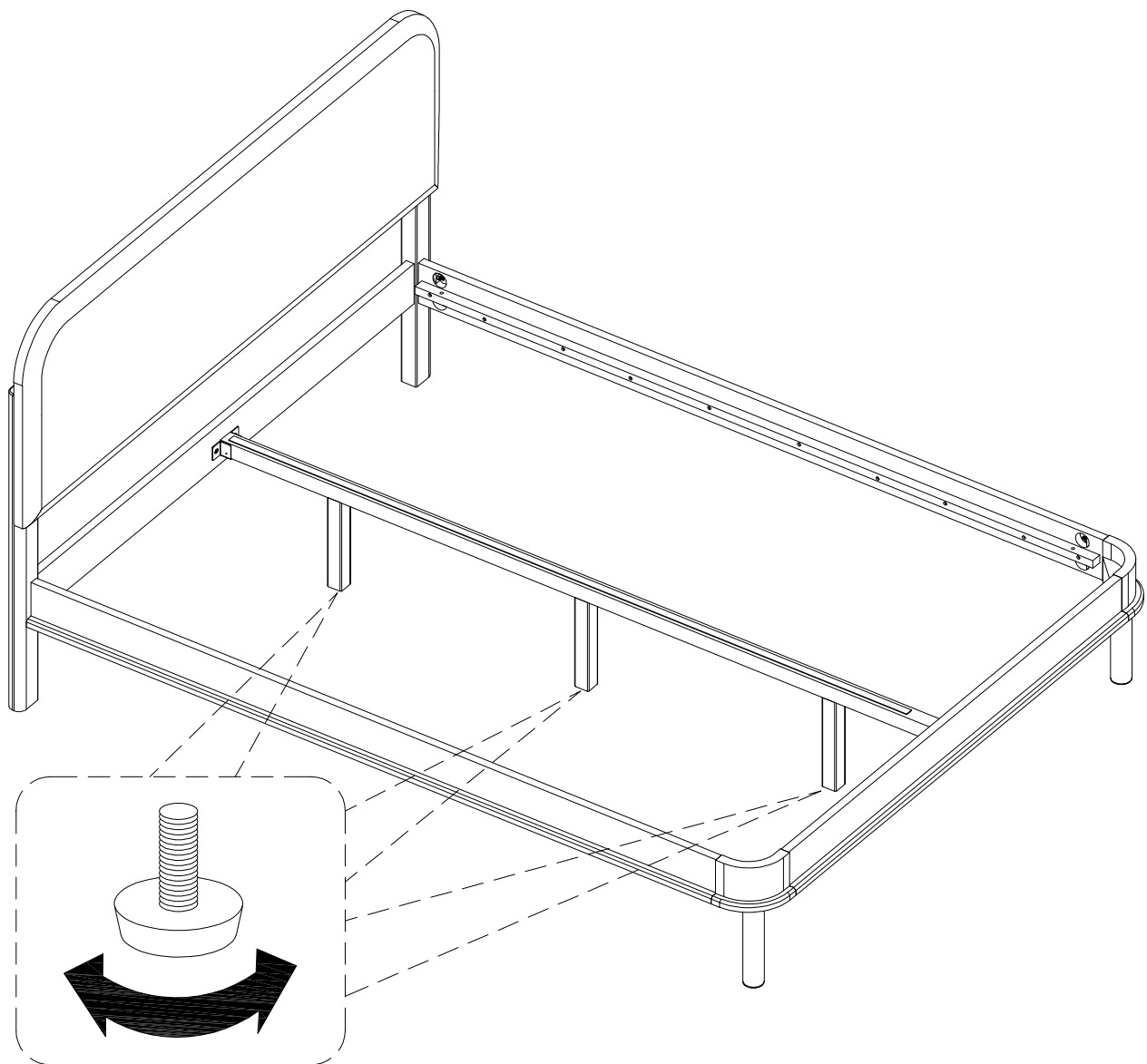

Step 15

Add the remaining Wooden dowels (A) into the ends inside slat supports of the Side Rails (5). (This will help when aligning the slats!)

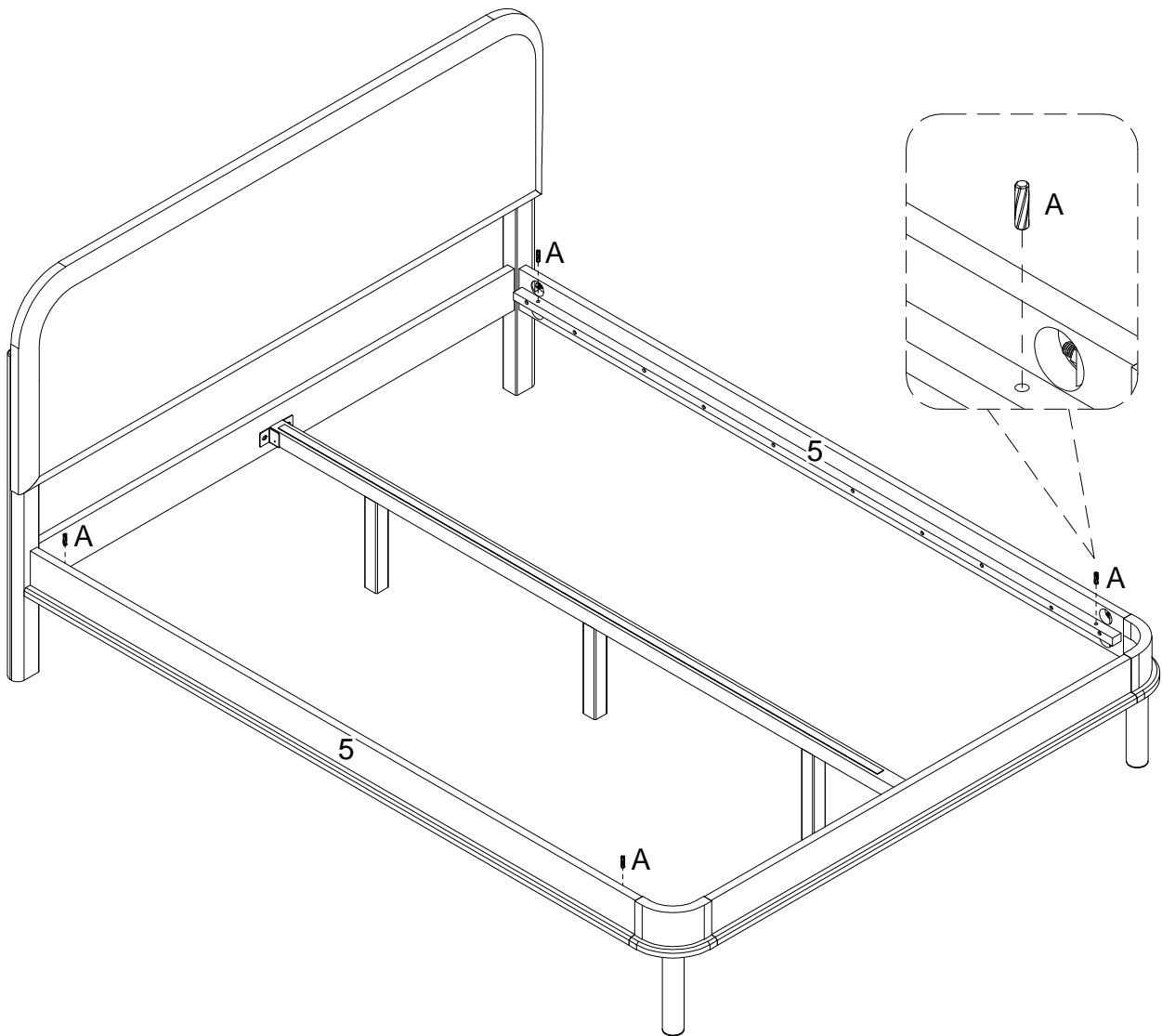

Step 16

Last step! Lay down the Bed Slats (11) and screw them into place with the six screws (M).

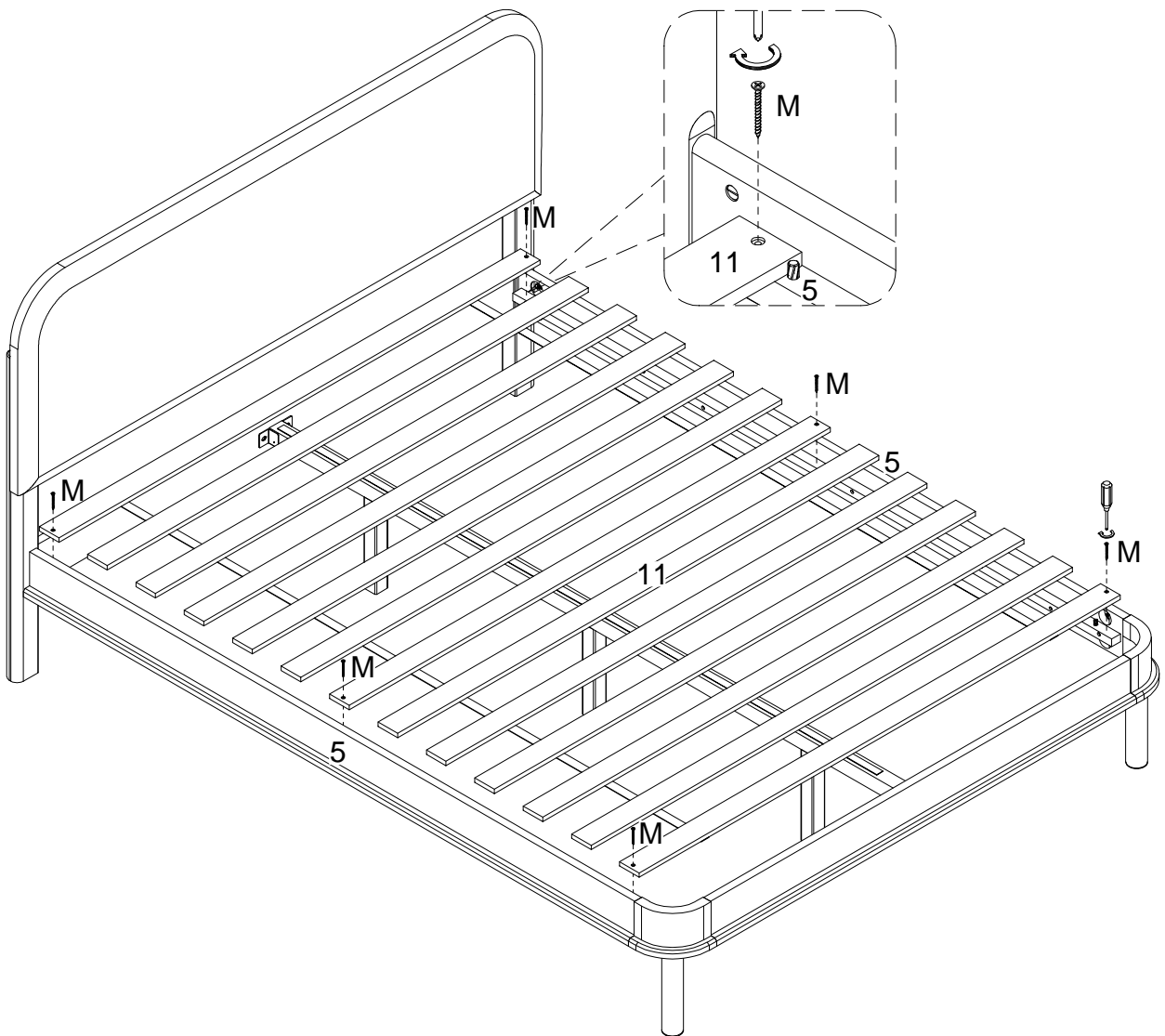

Final Assembly

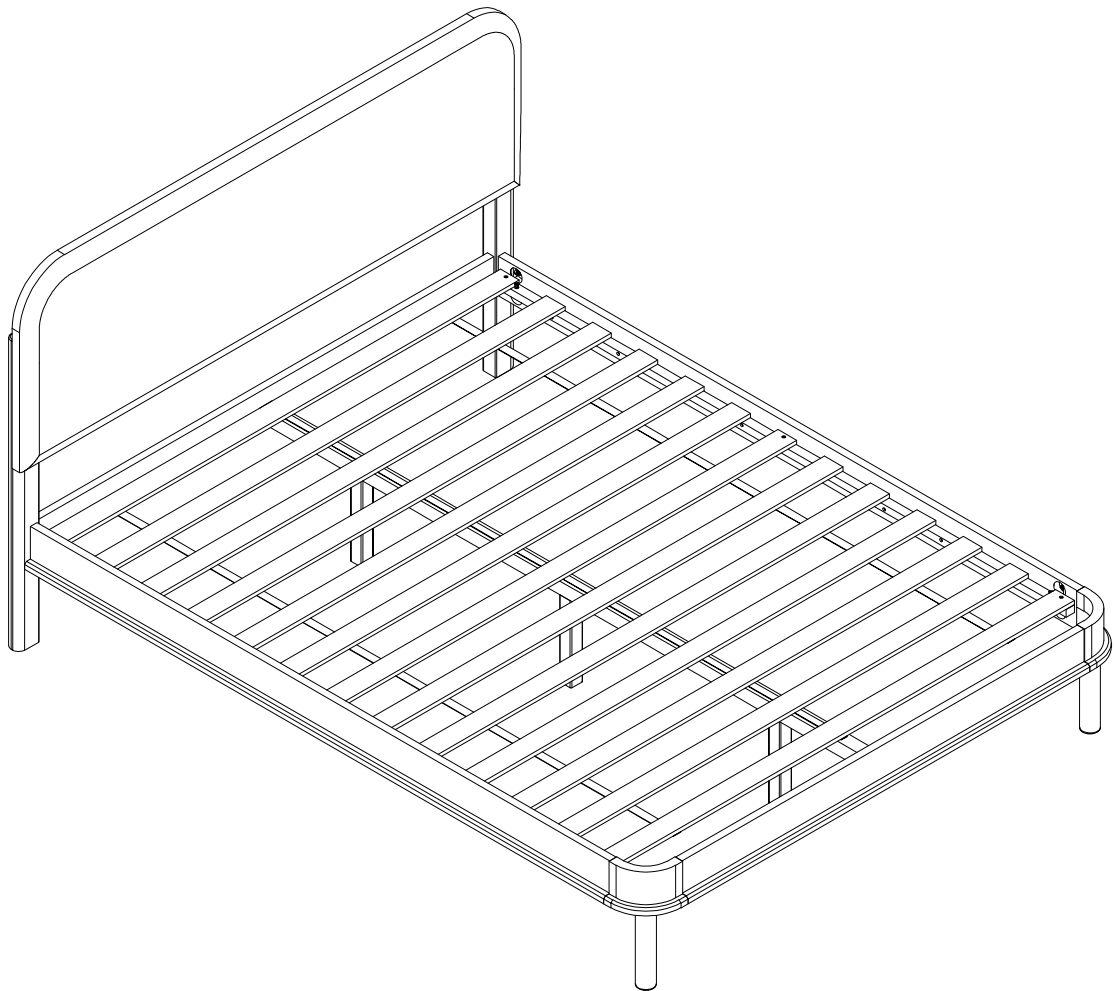

Congratulations on your new piece of furniture!

We would love to hear about it and see it.
Please leave us a review or post a picture with
[#mywalkerredisonhome](#)

Assembling furniture can be tricky sometimes.

Our customer service team, located in Utah, is here for product information, help assembling a product, or for any other customer support issue

Call us at **801-433-3008**

Email us at service@walkeredison.com

Visit our Customer Service website at walkeredison.com/pages/customer-service

We are available to help Monday -Thursday 8am-5pm, Friday 8am-3pm MST

For details on Assembly Videos, Assembly Instructions, Replacement Parts, and Customer service,
SCAN HERE

