

GLASSWAREHOUSE

LAN-HHOB90

530 Glass to wall for 10mm (3/8") - 15mm (19/32") glass

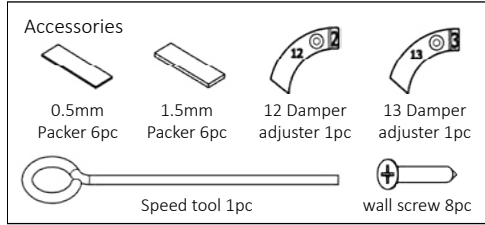

Installation

1. Check the wall or post alignment, making sure it is plumb and level. Also make sure the glass latch panel or post is plumb and in alignment.



Watch the install video



4. Place the gate panel with the fixed hinges into position on some timber blocks at the desired level and make sure it is plumb.

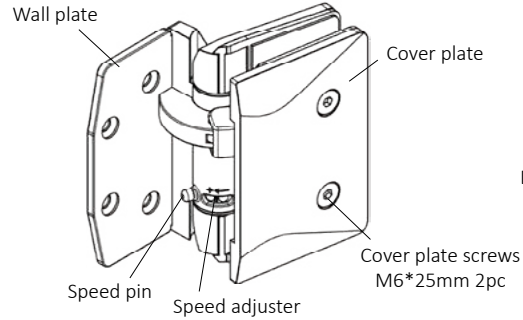
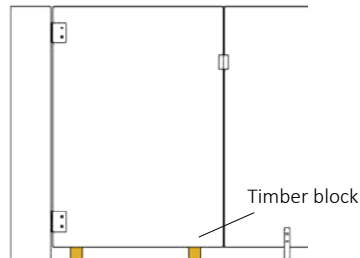

BACK- inside

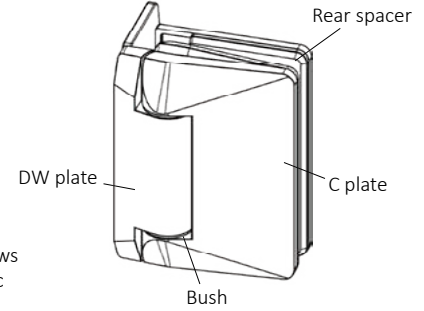

FRONT- outside

2. Undo the cover plate screws completely, then screw them back in 2 to 3 turns. For 12mm (1/2") and above panel thickness, remove the rear spacer. For 10mm (3/8") panel leave the rear spacer in.

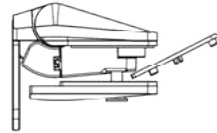

3. Take one hinge and slide it into the gate panel. With the hinge in the center of the cutout push all the way to the back of the cutout tighten the cover plate screws. Repeat these steps for the lower hinge.

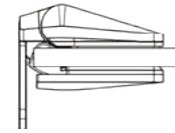

5. Pre drilling the holes for harder timbers or masonry. Then secure the first 2 wall screws on the top hinge into the timber. Repeat for the lower hinge. Carefully open the gate and secure the other 2 screws on each hinge.

6. Push packers in above the hinge for the glass to rest on. They should be pushed in past the level of the glass (see diagram). Repeat step 6 for bottom hinge.

