

BLACK DIAMOND®

Project Name: _____

Location: _____

Item #: _____

Qty: _____

Black Diamond Energy Star Gas Fryer, Liquid Propane, 45 lb, 84K BTU, in Stainless Steel

BDGF-ES45-LP



Easily deep-fry French fries, onion rings, chicken wings and more at your high-volume restaurant, bar or snack shop with the dependable Black Diamond Energy Star Gas Floor Deep Fryer. The powerful 84,000 BTU floor fryer is constructed of a 16-gauge, stainless steel tank to withstand the demands of your busy commercial kitchen. This energy-efficient fryer has a thermostat range of 200°F (93°C) to 400°F (204°C). Foods can be cooked to golden perfection, crisp on the outside and tender on the inside.

FEATURES AND CONSTRUCTION

- Best-in-class, energy-efficient design with Energy Star Certification
- The perfect choice for your high-volume restaurant, bar or snack shop
- Powerful, 65,000 BTU floor-standing, gas deep fryer accommodates busy commercial kitchen environments
- 16-gauge, stainless steel construction provides resiliency and long-term use
- Thermostat range of 200° F (93°C) to 400°F (204°C) for preparation of a wide variety of foods
- Automatic shut-off function if the fryer temperature exceeds 450°F (232°C)
- 45 lb oil capacity is ideal for high-volume kitchens
- Features two nickel-plated oblong wire mesh baskets, one nickel-plated tube rack, drain extension, built-in heat deflector and 4 casters
- Standing pilot light design provides an instant ignition source when heat is required
- Set up for use with Liquid Propane (LP)

FRYER ACCESSORIES (OPTIONAL)

- Stainless Steel Cover
- Joiner Strips
- Splash Guard
- Fryer baskets available in a variety of sizes

3RD PARTY APPROVALS



WARRANTY (USA / CANADA)

One (1) Year Limited Warranty on Parts and Labor, Five (5) Year Warranty on Stainless Steel Fry Tank

Contact us for details at 1.877.368.2797



INCLUDED COMPONENTS

- (4) Casters
- (2) Baskets
- (1) Basket Support Rack
- (1) Basket Hanging Plate
- (1) Oil Drainage Extension Pipe

TEMPERATURE

Overall Temperature (Fahrenheit):

- Minimum: 200° - Maximum: 400°F



Black Diamond Energy Star Gas Deep Fryer, LPG, 45 lb, 84K BTU

BDGF-ES45-LP

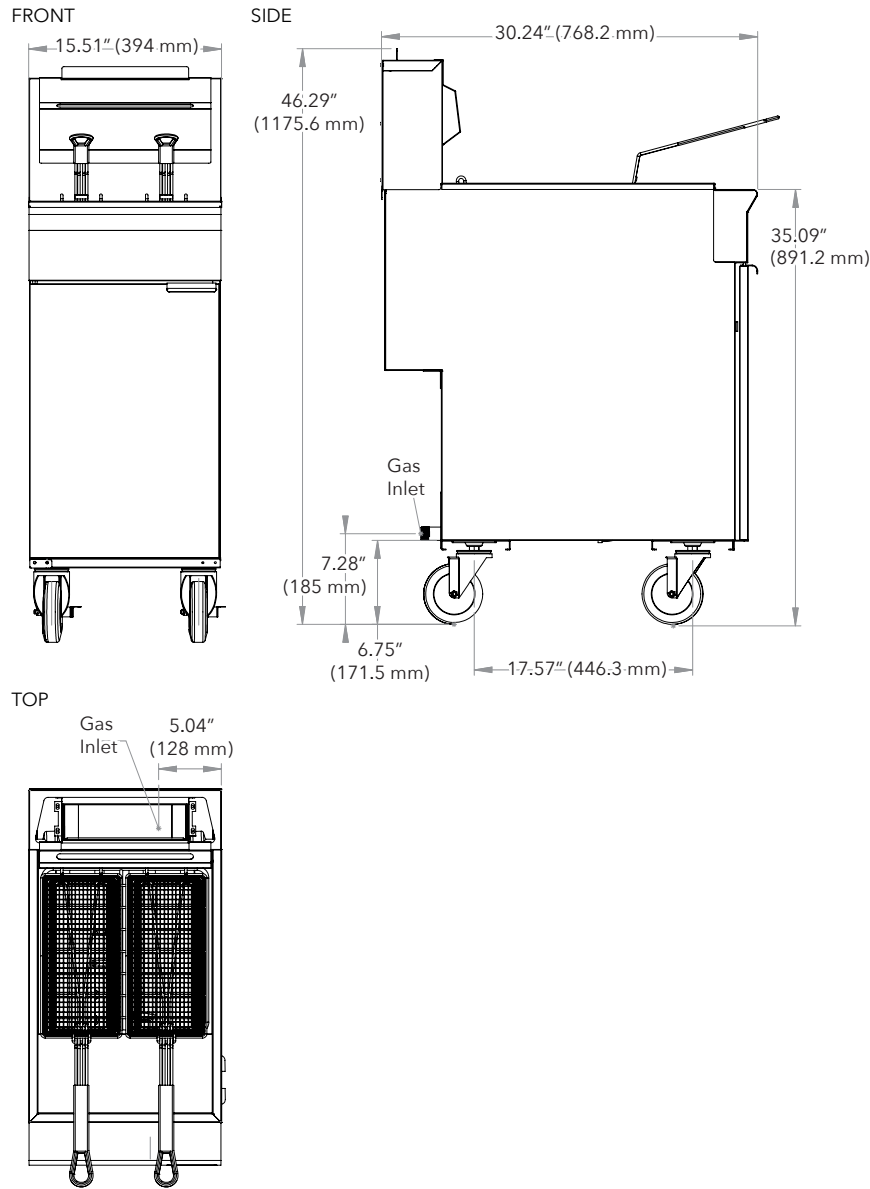

Gas

Capacity (lbs. of oil)	Temperature Range (Fahrenheit)	BTU / Hour	Assembled Dimensions (in)	Item Weight (lbs)	Shipping Weight (lbs)
------------------------	--------------------------------	------------	---------------------------	-------------------	-----------------------

45 lb	200° - 400°	84000	30.24" x 15.51" x 46.29"	147.5	167.3
-------	-------------	-------	--------------------------	-------	-------

ADDITIONAL INFORMATION

- Electricity not needed.
- Liquid Propane (LP) or Natural Gas (NG) units available. Field convertible from LP to NG and vice versa.
- Minimum supply pressure is 4" W.C. for natural gas and 10" W.C. for propane.
- Gas powered appliances must always be indoors, under an approved exhaust system with grease removal filters and a fire protection system.

Due to periodic changes in designs, methods, procedures, policies and regulations, the specifications contained in this document are subject to change without notice. While we exercise good faith efforts to provide information that is accurate, we are not responsible for errors or omissions in information provided or conclusions reached as a result of using the specifications. By using the information provided, the user assumes all risks in connection with such use.