

USER'S INSTRUCTION MANUAL

FOR STR-08 & STR-09

RESCUETM

BASKET STRETCHERS



NOTE: STRETCHER AND ACCESSORIES ARE NOT APPROVED IN HIGH ANGLE RESCUE SITUATIONS

1. Intended use

AeroRescue™ Single Shell and Twin Shell Basket Stretchers are devices designed for the rescue and transport of patients. They can be used in all rescue operations in which it is impossible to intervene with the standard transport methods and where the patient needs protection from possible side impact.

Basket stretchers can be hoisted with lifting devices fixed to the ground, maintaining in all cases the stretcher in a horizontal position to the ground. These devices are not designed for any intervention on behalf of the patient.

2. Main components

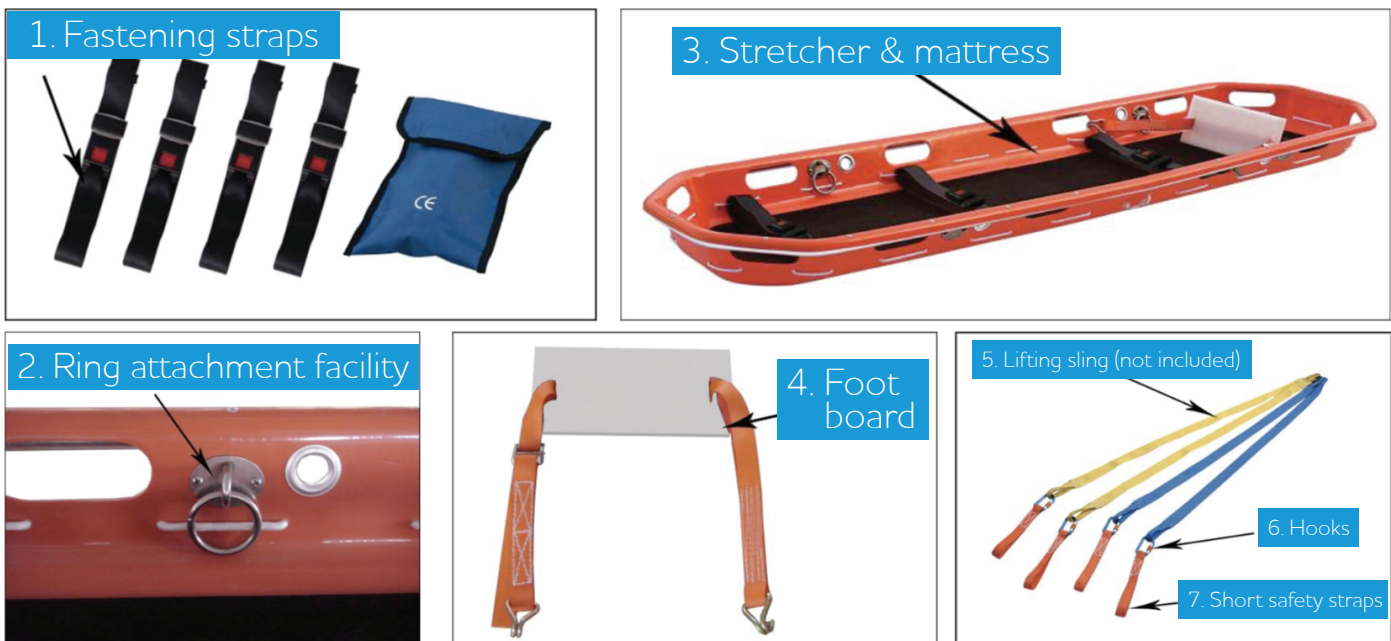

3. Technical data

Length	2150 mm
Width	650 mm
Height	190 mm
Load capacity	220 kg
Weight	18 kg
Number of handles	12
Material shell	High Density Polyethylene

NOTE: STRETCHER AND ACCESSORIES ARE NOT APPROVED IN HIGH ANGLE RESCUE SITUATIONS

4. Transport and storage

Before transporting the product, make sure that it is correctly packaged ensuring also that there are no risks of shocks, bumps or falls during the transport itself.

Keep the original packaging for use in case of any further transport and for storage. Damage to the stretcher caused during transport and handling is not covered by the guarantee. Repairs or replacement of the damaged parts are the

responsibility of the client. The device must be stored in a dry, cool area away from direct sunlight. It must not be placed in contact with any substances or chemical agents which could cause damage and reduce safety characteristics.

5. Preparation

On receipt of the product:

- Remove the packaging and display the stretcher so that all components are visible.
- Check that all the components/pieces on the accompanying list are present.
- Check that the product is correctly assembled and that all the rivets are tight
- Attach the safety belts by knotting them to the perimeter rope (Fig. A, B)

The device must be checked each time before use so that any function faults and/or damage caused during transport and/or during storage are detected.

Each time before use:

- Check that the perimeter rope is tight
- Check that the safety belts are correctly attached and adapt for immobilising the patient
- Make sure that the footrest is in position

If no faults are found, the stretcher is ready for use. If you require any further details regarding the routine checking, please contact **Aero Healthcare**.

If the stretcher presents any faults which you consider may compromise its correct and safe use, it must be immediately removed from service and you must contact **Aero Healthcare**.

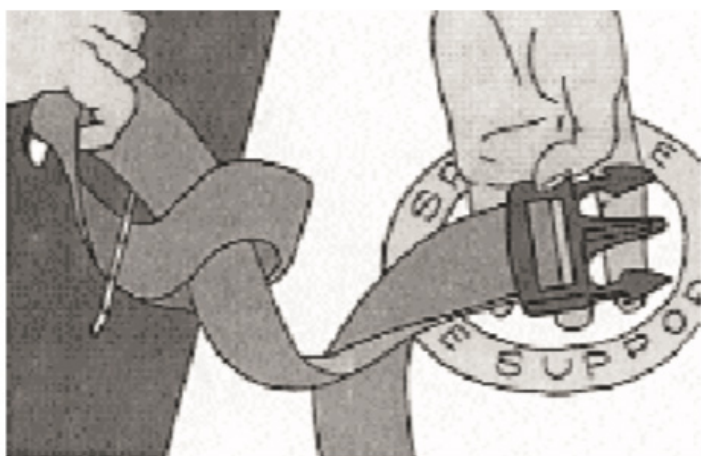

Fig. A

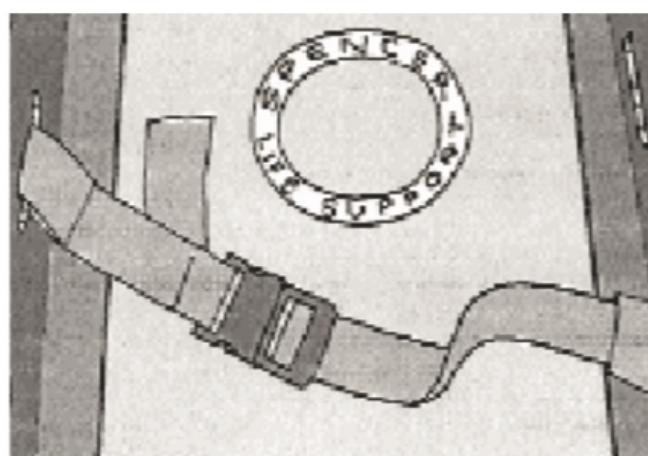

Fig. B

6. Functions

6.1 Loading the patient into the stretcher

Before moving, lifting or transporting the patient, the primary medical evaluations must be taken.

- After the diagnosis has been made, it is best (if possible) to suggest active co-operation to the patient while transferring him/her to the stretcher, by informing him/her at the same time about the risks involved. Depending on the patient's conditions, the environmental conditions and the rescue situation, the basket stretcher can be covered with one or more blankets to provide extra warmth and protection to the patient.
- Single Shell and Twin Shell basket stretchers are compatible with immobilisation systems such as spine boards equipped with their specific head immobilisers.
- In case of prior immobilisation onto a spine board, refer to the user's manual of these devices.
- Place the stretcher as close as possible to the patient before loading him/her.
- Load the patient following the specifications approved by the EMS Service.
- Secure the patient with the dedicated restraint belts provided with the product. Make sure to have fixed the safety belts firmly to the structure of the basket stretcher. Tightening of the straps according to the patient's condition.
- Position the footrest in the proper position so that its flat surface comes in contact with the patient's feet, in order to avoid longitudinal movements.
- Insert the buckles at the end of the belts through the button holes/handles on the perimeter of the Single Shell and Twin Shell (Fig. C and D).
- Check that the footrest is correctly centered on the belts and that it maintains a perpendicular position to the platform of the stretcher.

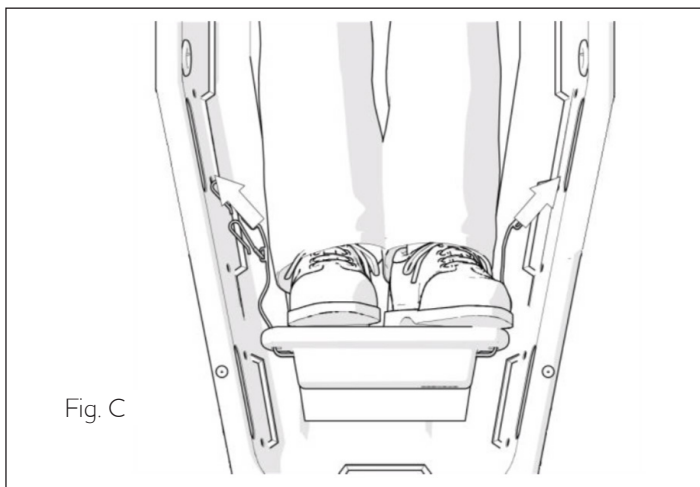

Fig. C

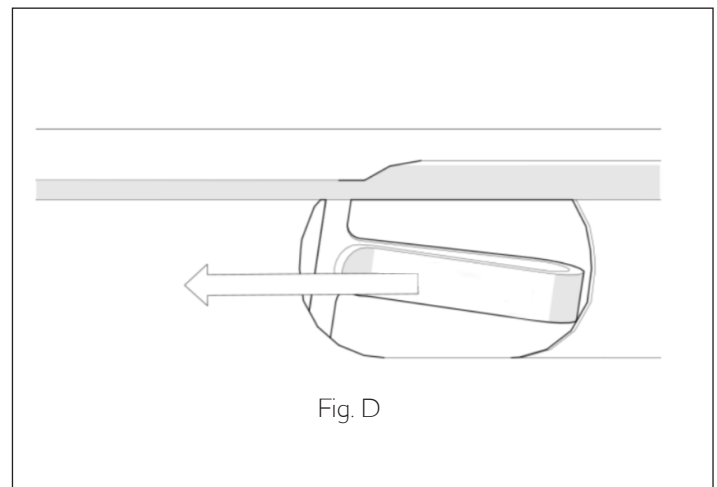

Fig. D

If the patient has leg injuries, immobilise the legs with the adequate devices approved by the EMS Service for immobilisation and transport of patient. Secure the patient to the basket stretcher with belts according to the decision of the rescue leader (it is recommended to use a supplementary pair of belts in the shoulder and chest area, positioned in a cross).

6.2 Lifting the stretcher with the patient

Before starting the transport, the patient should be secured to the basket stretcher by means of special belts to ensure stability and security.

- The carrying of the stretcher requires a minimum of two operators: one at the foot-end, the other one at the head-end.
- If the load is high or the stretcher needs to be transported for long distances or long trails that make the rescue more difficult, the rescuers will have to be in greater number.
- It is recommended to maintain a symmetrical arrangement of operators and helpers, in order to maintain the stretcher the more balanced and leveled as possible.
- Using a correct lifting technique, which will avoid excessive strain, each operator should take a strong grasp of the handholds at each end of the basket stretcher and lift the device.

6.3 Dragging the stretcher

Some rescue situations may require sliding the stretcher on the ground.

- In these cases, avoid dragging the stretcher over stones, branches or other dangerous surfaces which may affect the integrity of the device.



- When towing or using of other special equipment for the basket stretcher, rescue is considered high profile and should be completed by highly trained operators.

We recommend the use of appropriate personal protective equipment.

6.4 Hoisting the stretcher

Before every operation of this type, make sure you have checked the device as indicated in paragraph 5. Verify that all the procedures of fastening and immobilisation of the patient have been performed as described by the EMS Service and that the hoisting is compatible with the injuries suffered by the patient. Negligence and non-compliance could lead to fatal consequences.

Given the variety of recovery situations, the choice of immobilisation systems suitable for the hoisting operations and the choice of the stretcher to be used is full responsibility of rescue personnel, who must therefore be properly trained on how to operate and what security systems to adopt to carry out this activity.

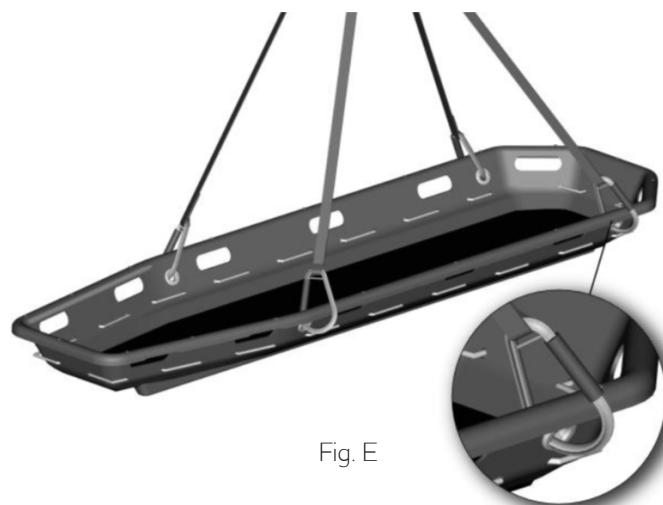

Fig. E

During hoisting, the maximum load capacity indicated for the single stretchers is deemed to include the weight of the stretcher, patient, rescue equipment and, in cases where it is applicable, the weight of the rescuer and whatever else included or applied to the stretcher's structure.

- During hoisting operations, the stretcher can be suspended only horizontally to the ground.
- Ensure the patient is fastened to the stretcher so they do not slide longitudinally or laterally or out of the stretcher. In case of horizontal hoisting, the lifting bridles (supplied as accessories) must be anchored in the areas on the frame, where the metal rings are arranged, as shown in Fig. E.
- If necessary, attach additional ropes to the basket stretcher, (in structural points).

6.5 Attaching the bridle

1. **Align the Sides:** Lay the stretcher flat and ensure both bridle attachment points are aligned.
2. **Slide to Connect:** Slide the aligned sides together until the ends meet flush.
3. **Close Tightly:** Firmly press connectors to close the structure.
4. **Insert the Metal Rod:** Slide the metal rod through the central channel to reinforce stability.
5. **Insert Clips and Lock:** Insert clips into side loops and lock to prevent release.
6. **Secure the Three Buckles:** Evenly tighten all three buckles, ensuring straps are snug for balanced load.
7. **Insert the Tie Strap:** Feed the orange strap through the tab, keeping it flat and untwisted.
8. **Pull the Loop Tight:** Firmly pull the loop to tighten connection.
9. **Attach the Carabiner:** Clip the carabiner to the final point and ensure the gate is securely locked.



Fig. F

Do not tie the straps in other areas, since it does not ensure perfect tightening and balance of the stretcher. Fasten people and accessories only to the main structure of the stretcher, without limiting the functionality of the patient on the inside. Always assist the patient during all manoeuvres.

6.6 Installation/dismantling of the parts of Twin Shell

- Do this activity with a minimum of two operators and use appropriate personal protective equipment.

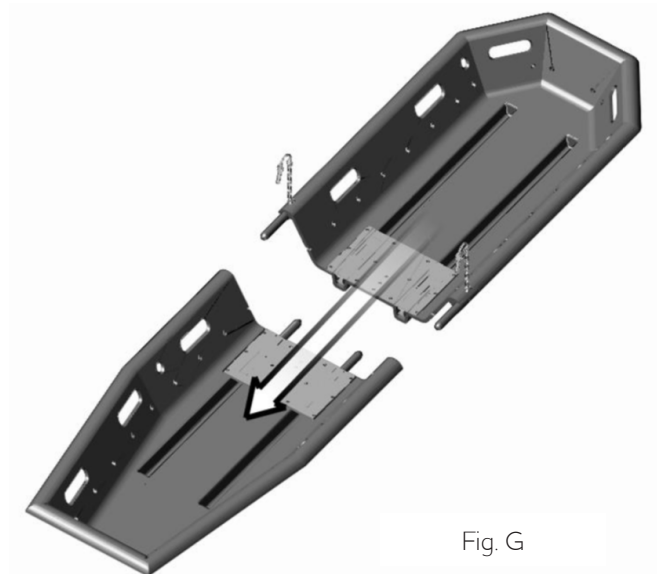

Fig. G

- The two separate parts of the stretcher are joined by inserting the pins on one half (Fig. G) into the specific holes on the other half of the stretcher. The two parts of the Twin Shell must be joined with care, checking there is no unnatural obstruction and that the pins are neatly secured into position.

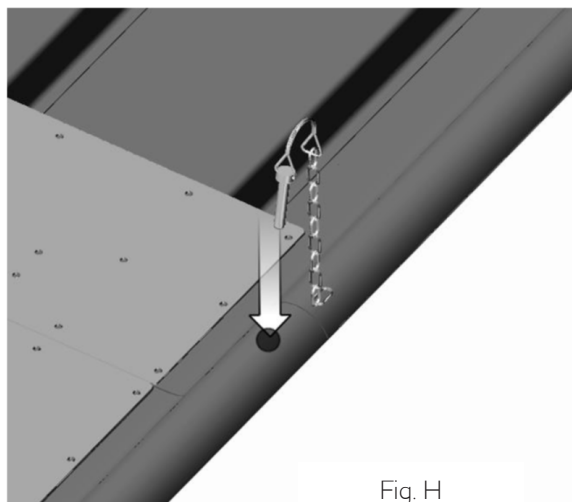

Fig. H



Fig. I

- Position the fixing pin (Fig. H) in the corresponding hole on the other half of the Twin Shell, making sure to lock the pin once inserted (the same operation must be carried out on the other side).

- Insert clips and lock (Fig. I).

Before operating, make sure that the structure is firmly stable and all the hooks properly secured.

7. Troubleshooting

PROBLEM	CAUSE	SOLUTION
Damage to the shell	Improper use	Immediately remove the device from service and contact the Customer Care Service
Damage to the edge riveting	Improper use	Immediately remove the device from service and contact the Customer Care Service
Difficulties in assembling the parts (only Twin Shell)	Dirty inlets	Clean thoroughly inlets in both the convex and the concave part
When lifting the stretcher, it does not remain aligned (only Twin Shell)	Wrong assembly of parts	Disassemble and reassemble the parts, carefully checking the stretcher
The stretcher is not securely blocked (only Twin Shell)	Break of the safety device	Immediately remove the device from service and contact the Customer Care Service

8. Cleaning and maintenance

The operator must always wear adequate personal protection such as gloves and mask etc. during all checking and cleaning procedures.

In the presence of blood, oxidize it before to washing the device with water.

Checks to be carried out before and after each use, and at least every month, are as follows:

- General functionality of the device
- Cleanliness of the device (failure to clean may lead to cross infections)
- Absence of cuts, holes, tears on the structure, including the straps
- Correct fixation of all nuts, bolts and screws
- Correct fixation of straps
- Correct fastening of straps
- State of use (moving parts, belts)

