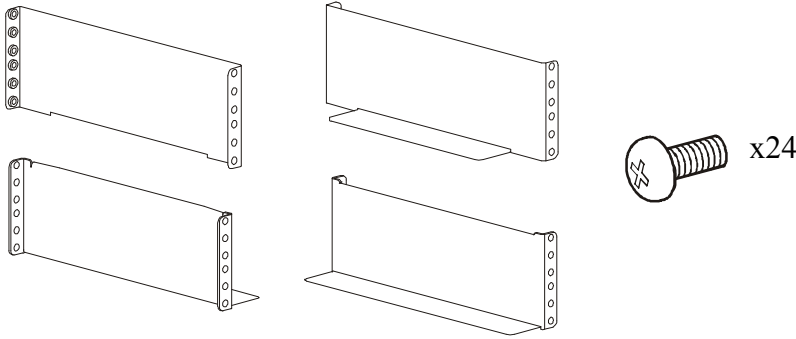
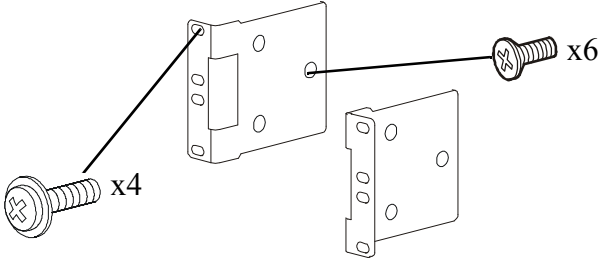
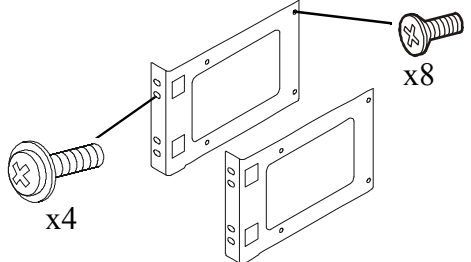
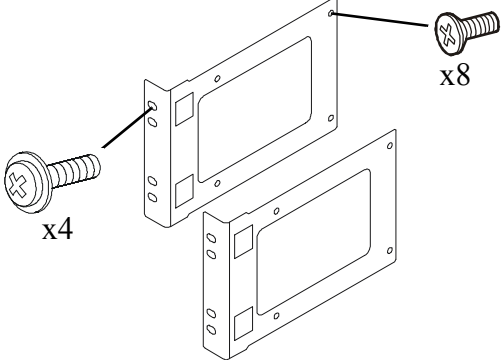
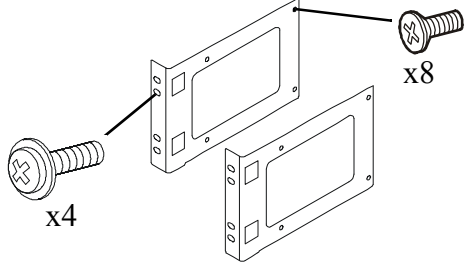

Installation Guide Smart-UPS[™] On-Line SRT 2-Post Rack-Mount Rail Kit

Package Contents

Inspect the contents upon receipt. Notify the carrier and dealer if the unit is damaged.

<p>All Models</p> <ul style="list-style-type: none"> • 2 pairs of rails • 24 pan head screws 	
<p>SRT1000/SRT1500 and SRT2200/SRT3000, 2U models</p> 	<p>SRT5K, 3U models and SRT external battery packs</p> 
<p>SRT6K, 4U models</p> 	<p>SRT8K/SRT10K, 6U models</p> 

Install Rails to 2-Post Rack

Pem nuts are provided on single side of two rails. Install these rails such that the pem nut is towards the front of the 2-post rack.

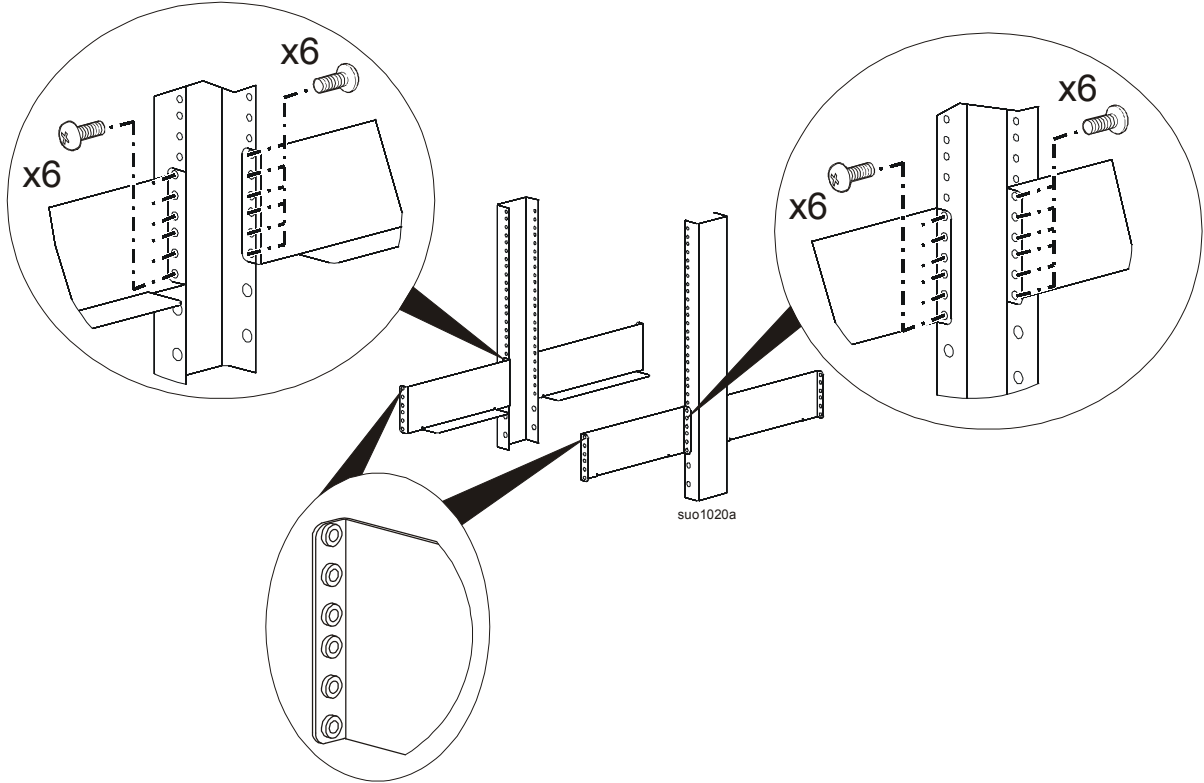

SRT1000/SRT1500/SRT2200/SRT3000 UPS

Note: UPS and External Battery Pack (XLBP) models may differ in appearance from those depicted in these graphics. The installation process is identical for all models.

⚠ CAUTION

DAMAGE TO EQUIPMENT OR PERSONNEL

- The equipment is heavy. Each APCRBC152 battery module weighs 16.4 kg (36.2 lbs) and each APCRBC141 battery module weighs 12.5 kg (27.6 lb). Each APCRBC155 battery module weighs 11 kg (24.25 lb).
- Always practice safe lifting techniques adequate for the weight of the equipment.
- Remove the battery modules before installing the UPS.
- Use the battery module handle to carefully slide the battery module in or out of the unit.
- Do not use the battery module handle to lift or carry the battery module.
- Place the UPS on a table to remove the stabilizer brackets.
- Always install the UPS at the bottom of the rack.
- Always install the XLBP below the UPS in the rack.

Failure to follow these instructions can result in equipment damage and minor or moderate injury.

Tower to rack-mount conversion

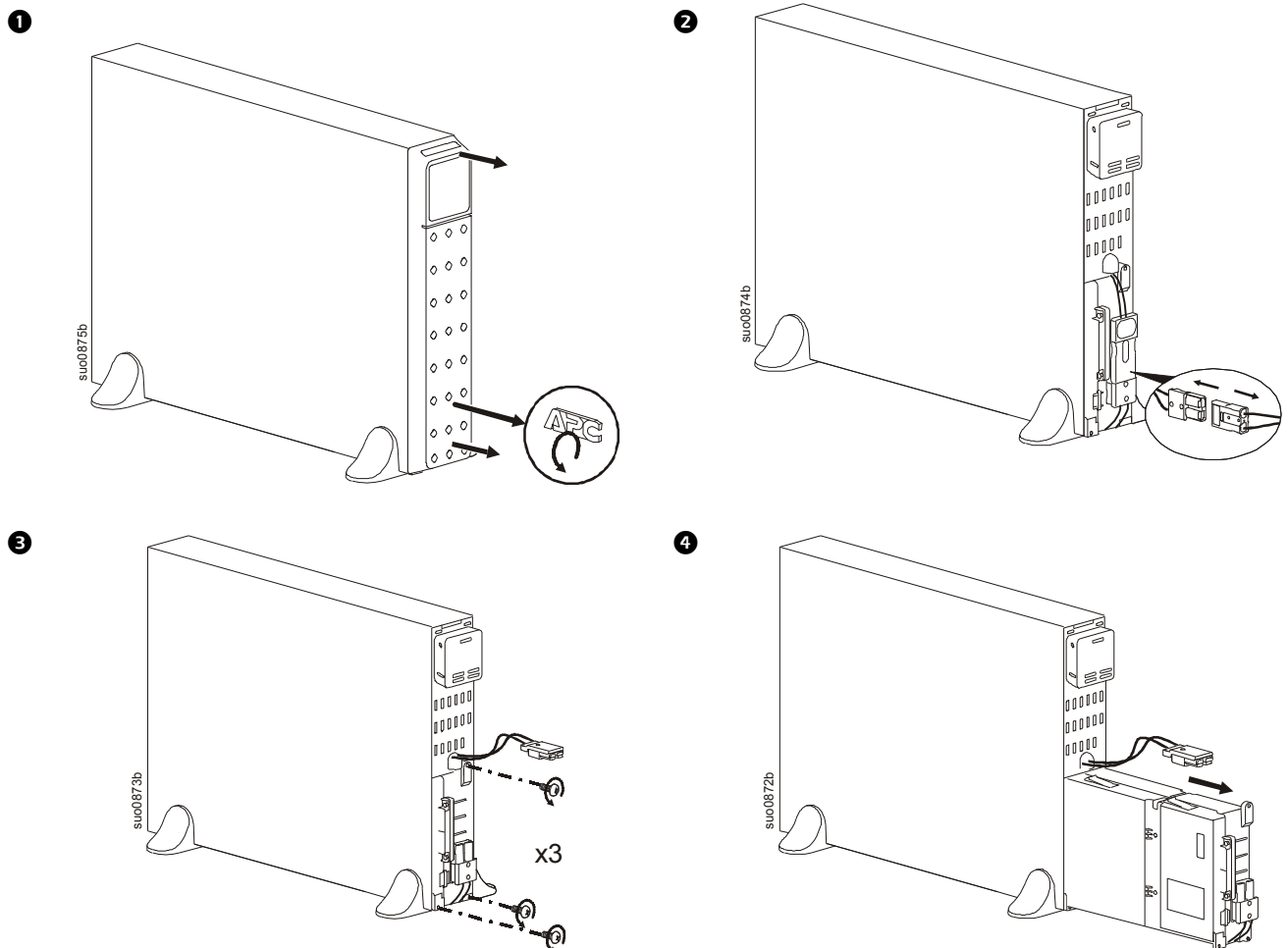

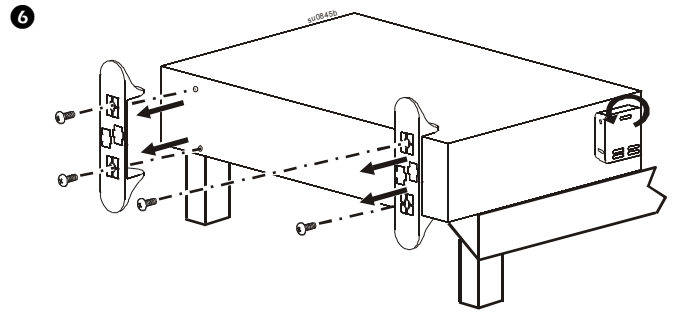
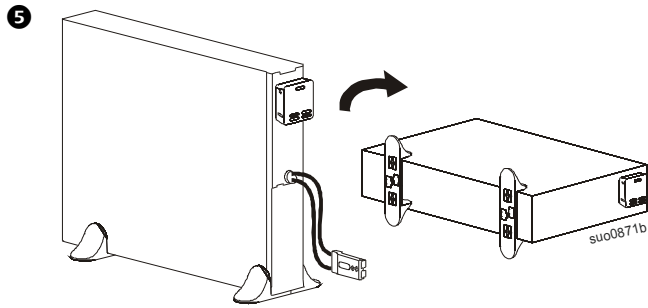

Install the SRT1000/SRT1500/SRT2200/SRT3000 UPS in a rack

See “Install Rails to 2-Post Rack” on page 2 for instructions on rail installation.

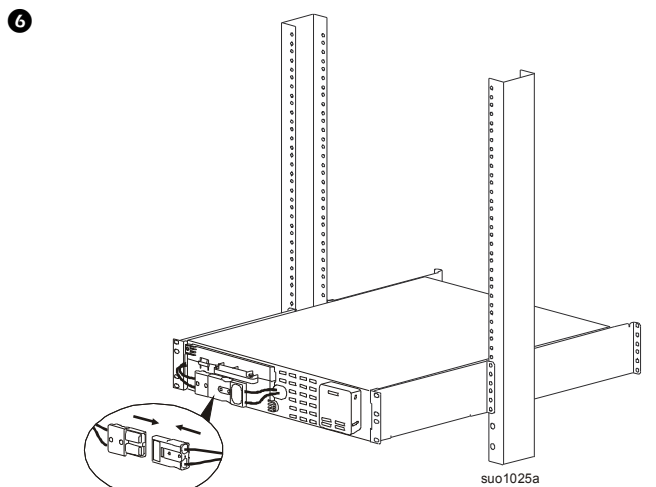
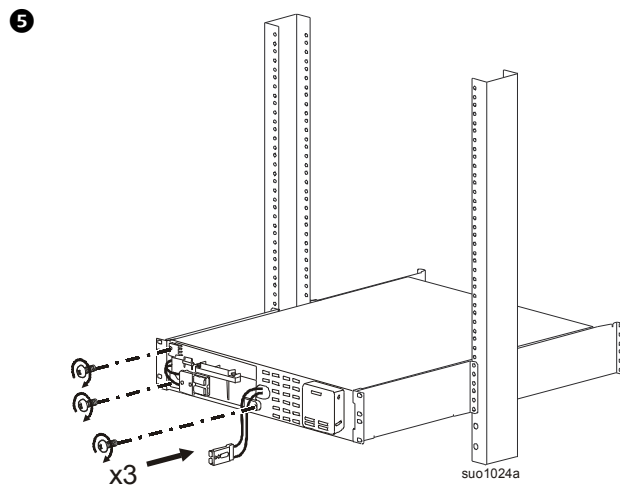
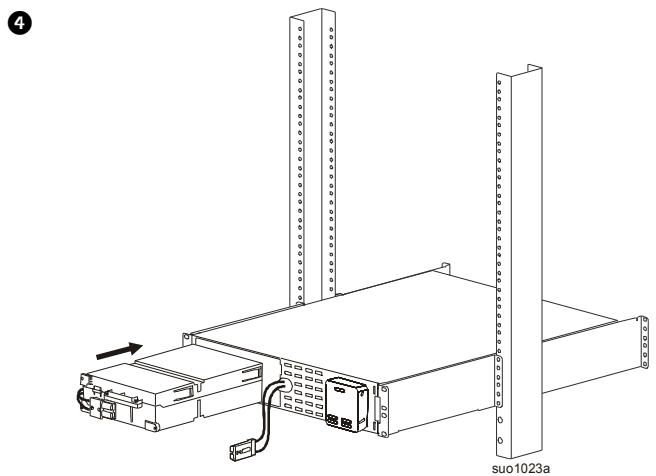
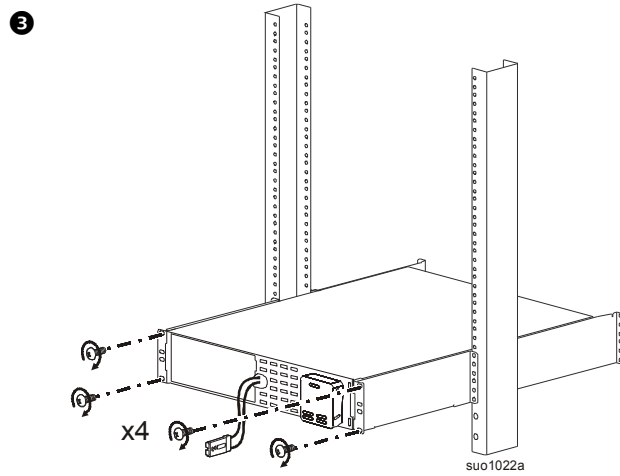
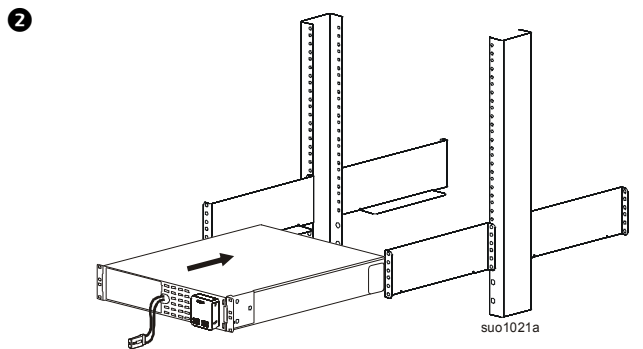
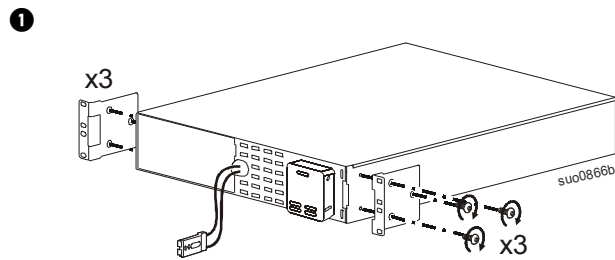

7

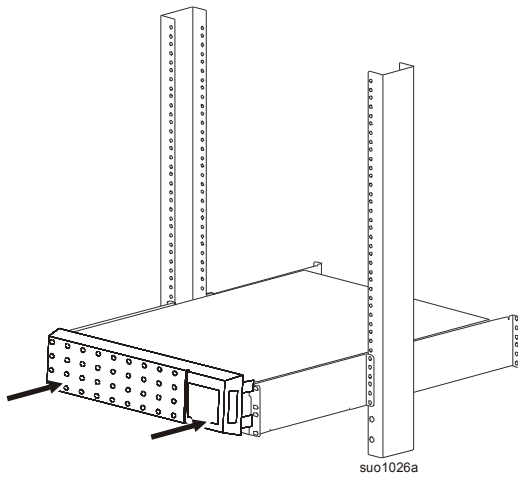

SRT1000/SRT1500/SRT2200/SRT3000 UPS with one external battery pack

1

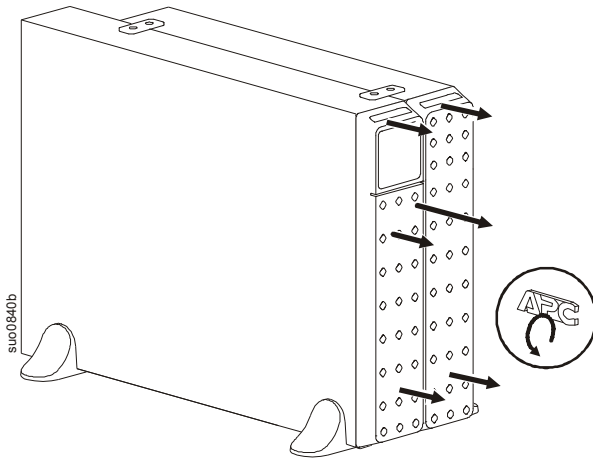

2

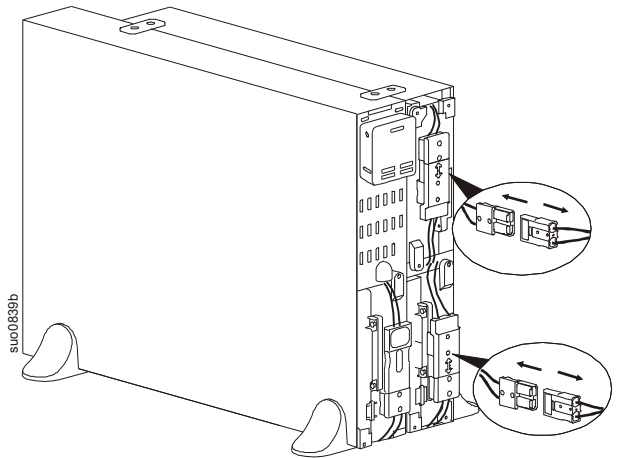

3

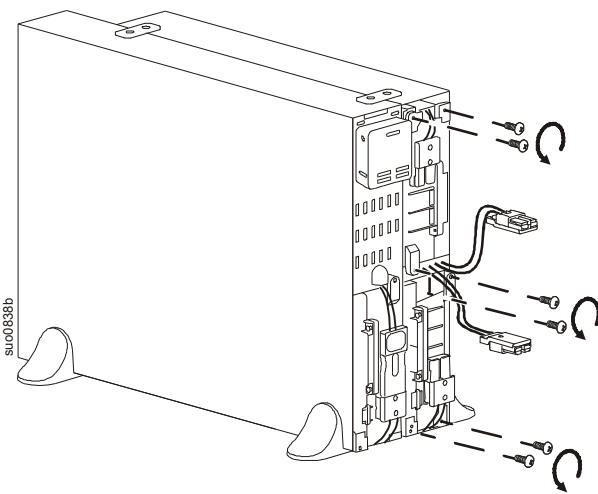

4

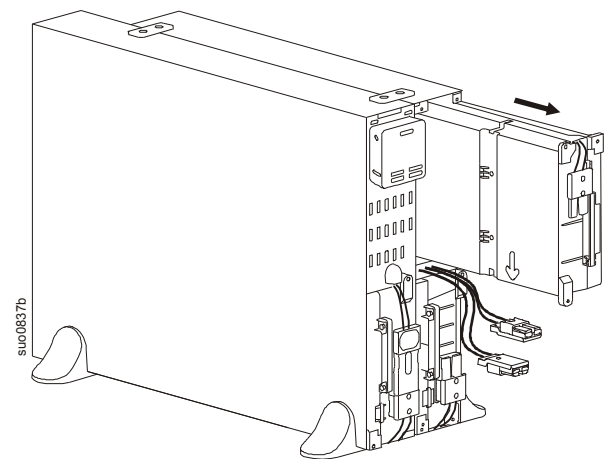

5

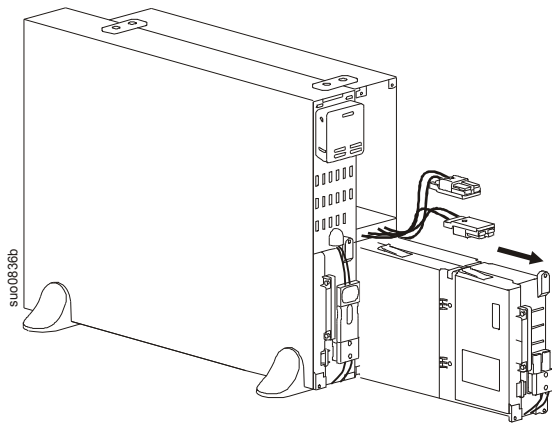

6

Disconnect and remove the battery module from the UPS. See "Tower to rack-mount conversion" on page 3.

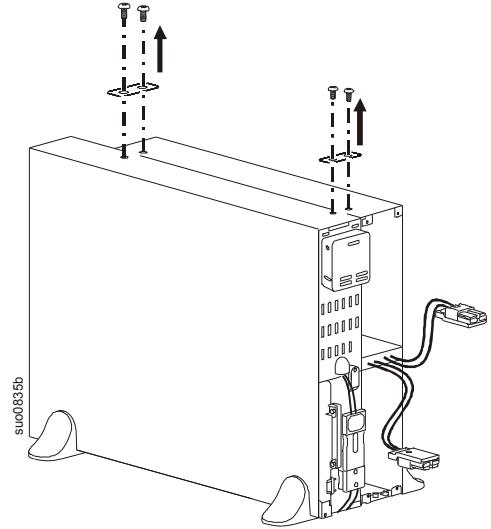

7

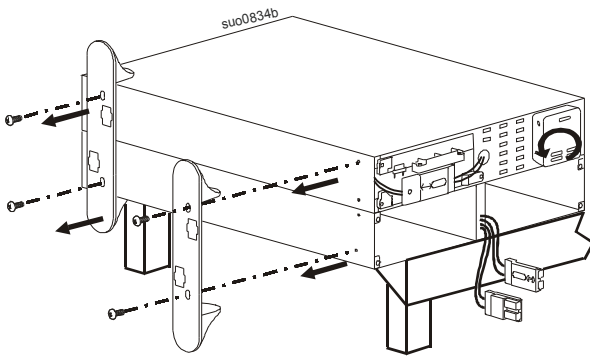

Install the SRT1000/SRT1500/SRT2200/SRT3000 UPS with one external battery pack in a rack

See "Install Rails to 2-Post Rack" on page 2 for instructions on rail installation.

1

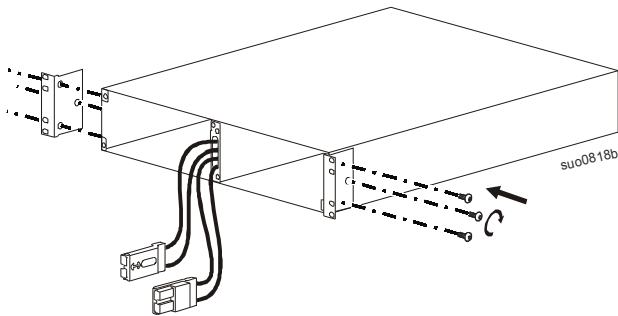

2

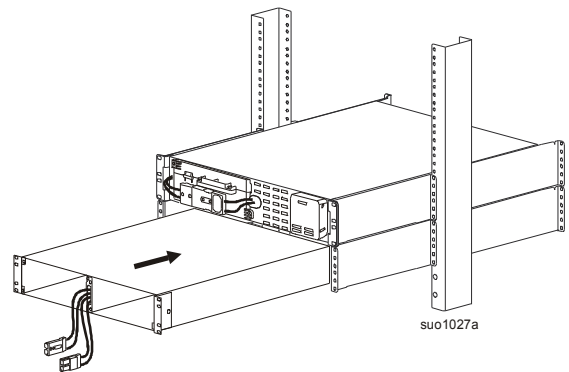

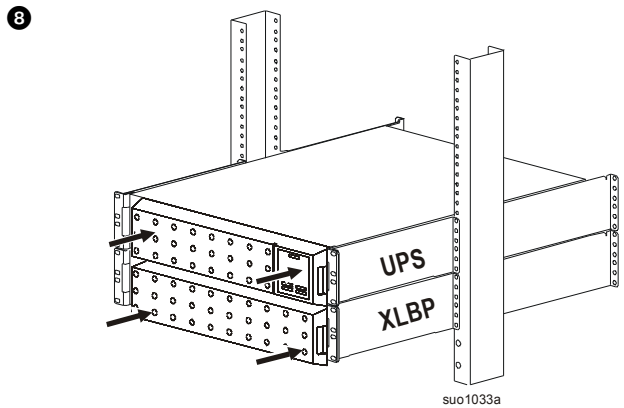
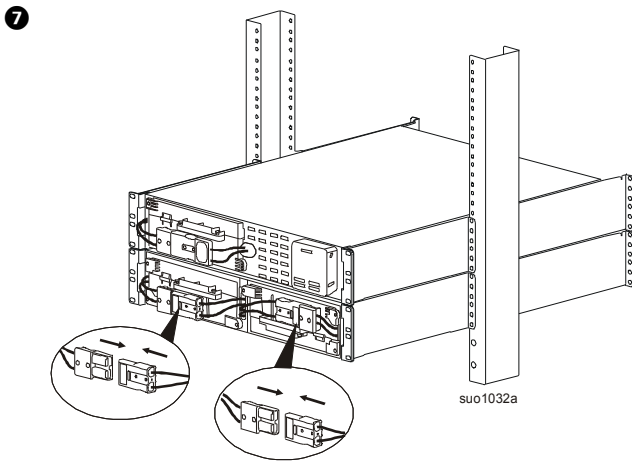
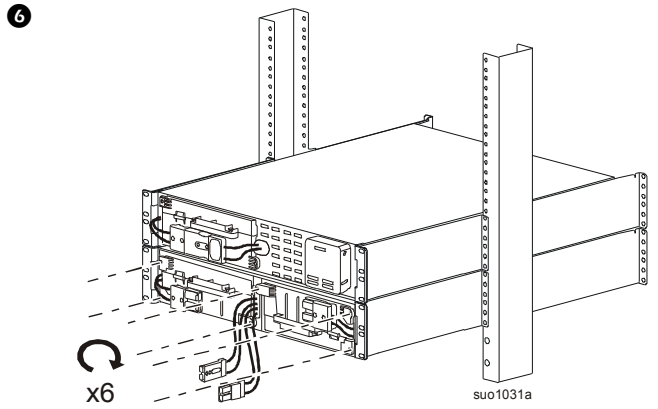
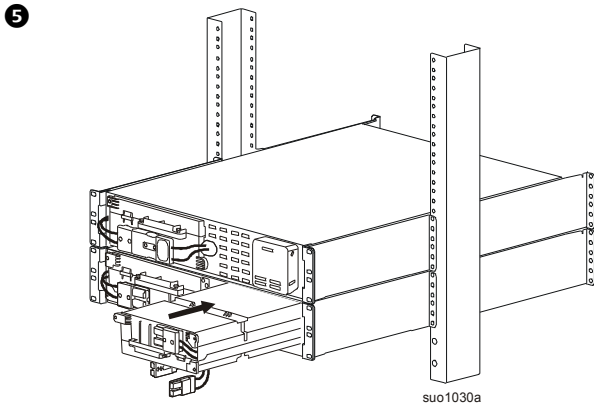
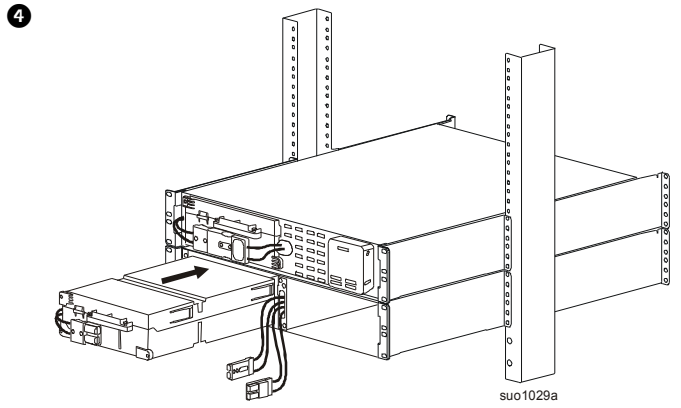
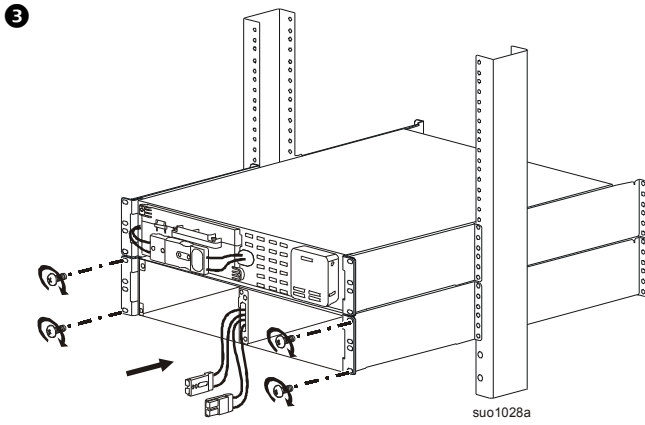

SRT5K/SRT6K UPS

CAUTION

DAMAGE TO EQUIPMENT OR PERSONNEL

- The equipment is heavy. Each APCRBC140 battery module weighs 17 kg (37 lb).
- Always practice safe lifting techniques adequate for the weight of the equipment.
- Remove the battery modules before installing the UPS.
- Use the battery module handle to carefully slide the battery module in or out of the unit.
- Do not use the battery module handle to lift or carry the battery module.
- Place the UPS on a table to remove the stabilizer brackets.
- Always install the UPS at the bottom of the rack.
- Always install the XLBP below the UPS in the rack.

Failure to follow these instructions can result in equipment damage and minor or moderate injury.

Tower to rack-mount conversion

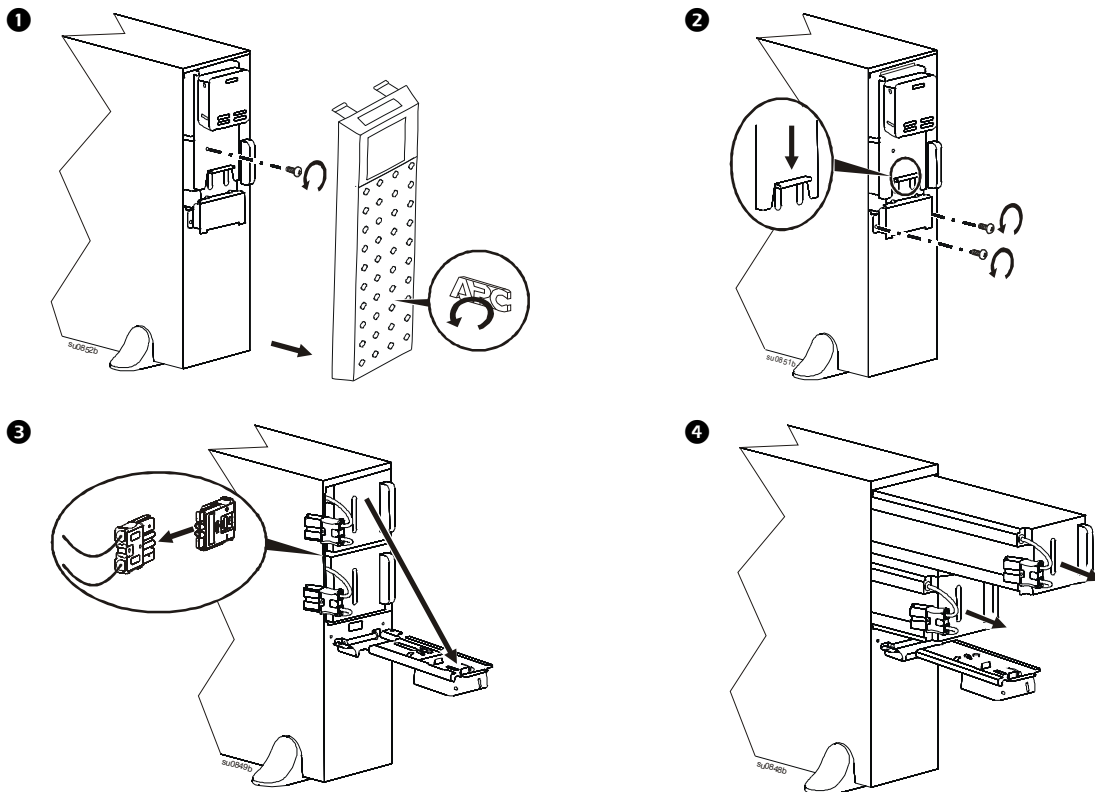

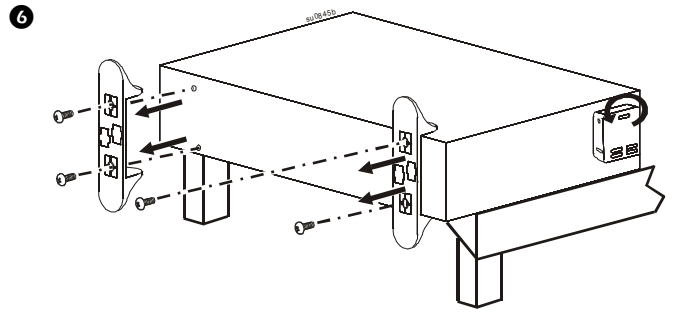
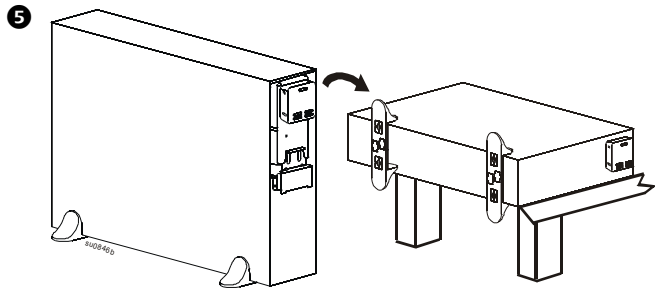

Install the SRT5K/SRT6K UPS in a rack

See “Install Rails to 2-Post Rack” on page 2 for instructions on rail installation.

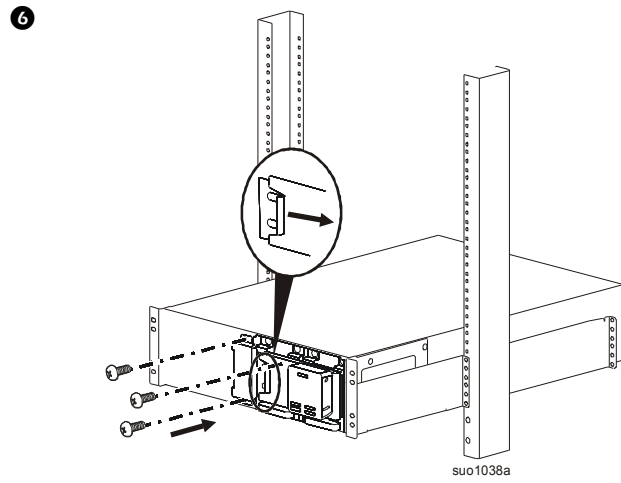
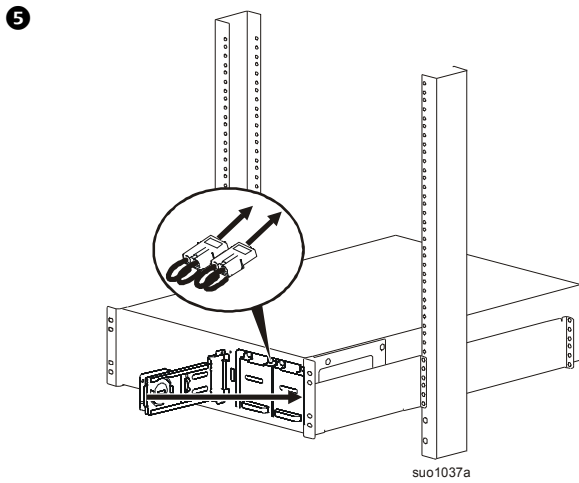
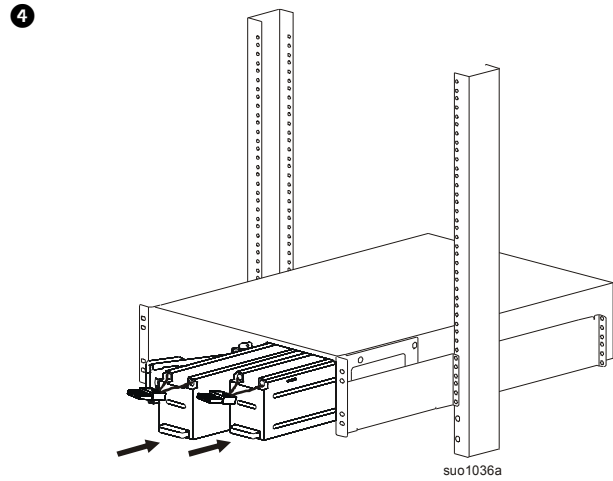
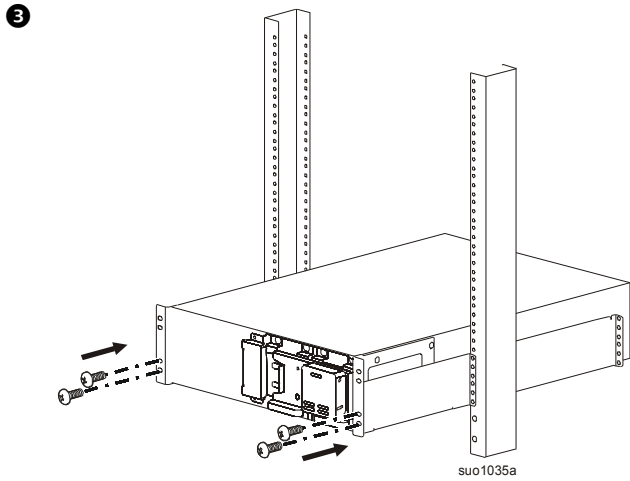
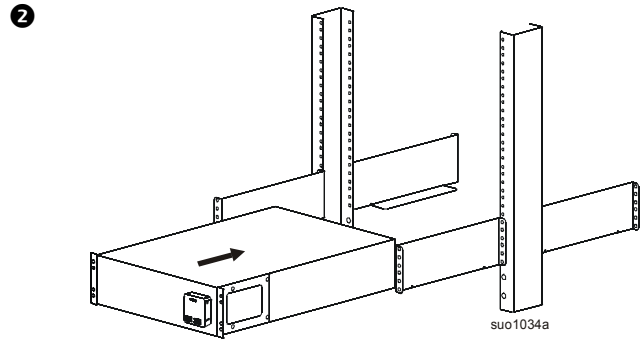
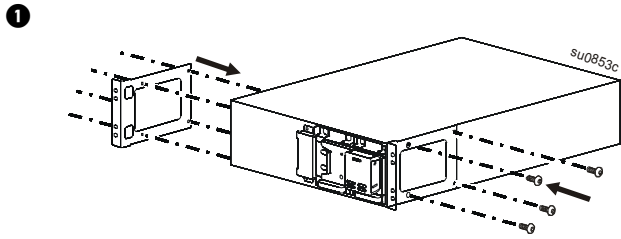

7

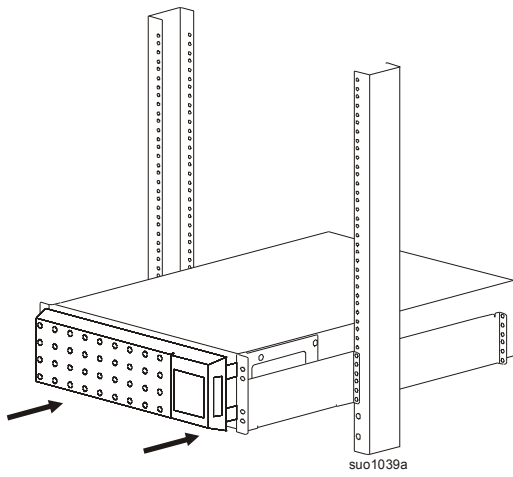

SRT5K/SRT6K UPS with one external battery pack

1

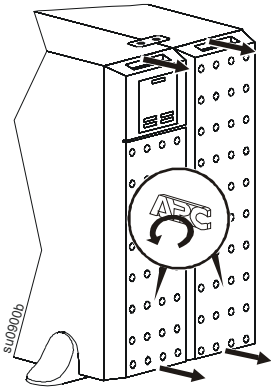

2

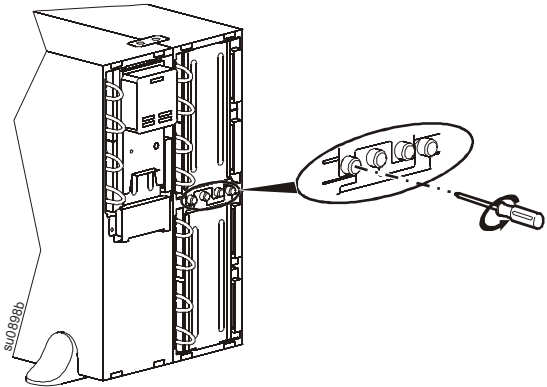

3

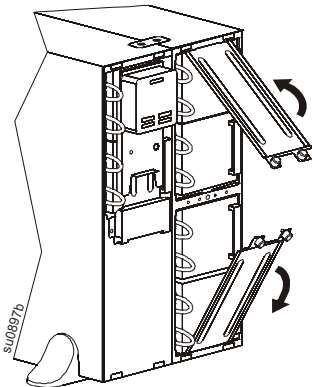

4

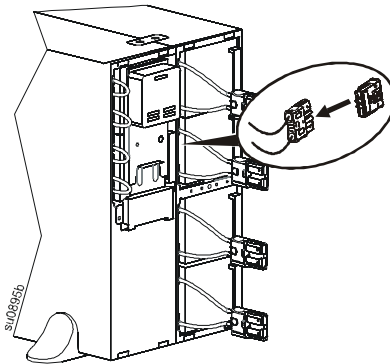

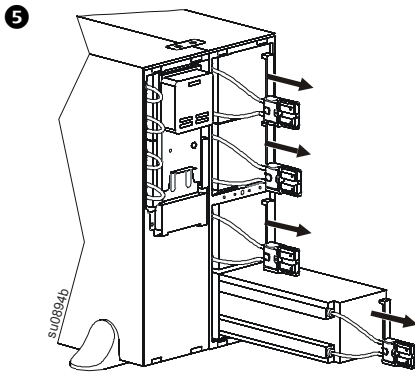

- 6 Disconnect and remove the battery module from the UPS. See “Tower to rack-mount conversion” on page 14.

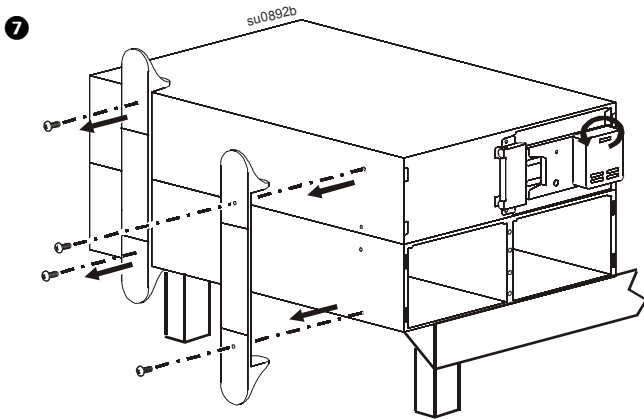
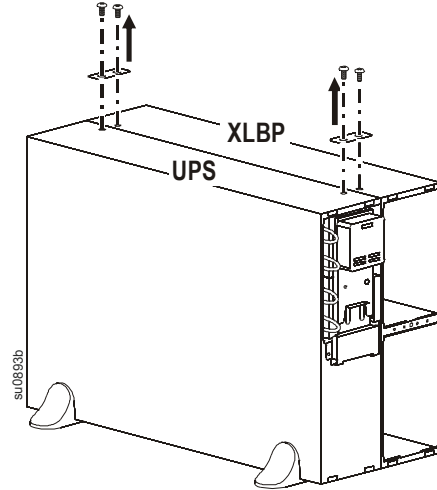

Install the SRT5K/SRT6K UPS with one external battery pack in a rack

The process for installation of an external battery pack with UPS models SRT8K/SRT10K models is identical to that described for the SRT5K/SRT6K models.

See “Install Rails to 2-Post Rack” on page 2 for instructions on rail installation.

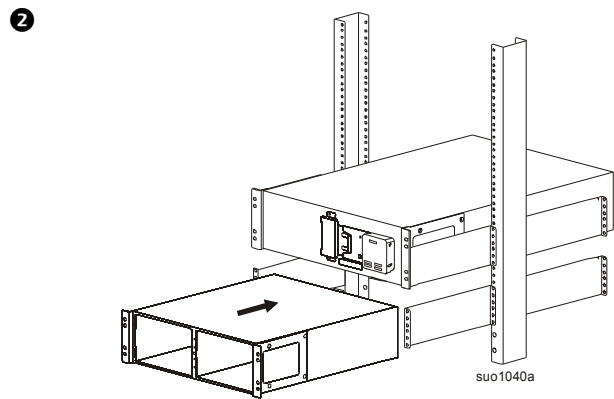
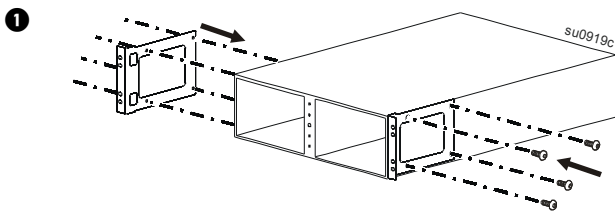

3

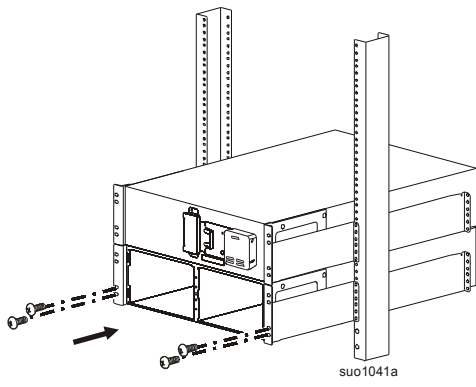

4

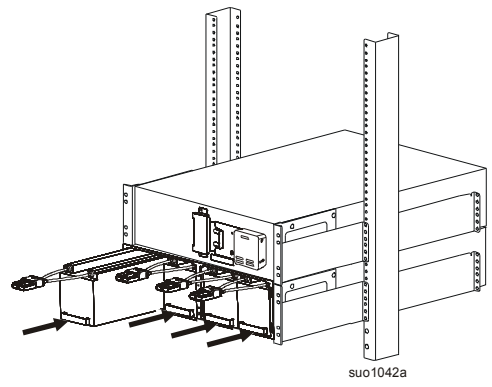

3

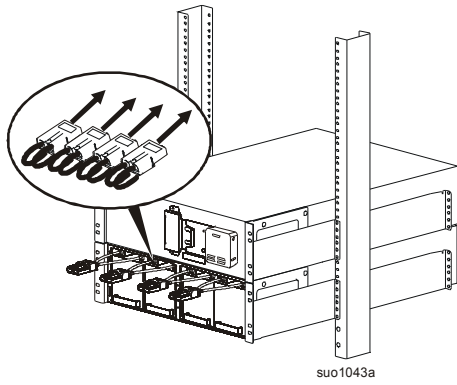

4

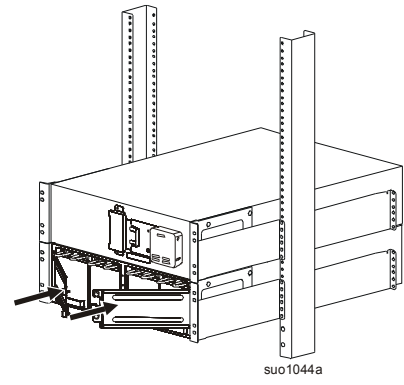

5

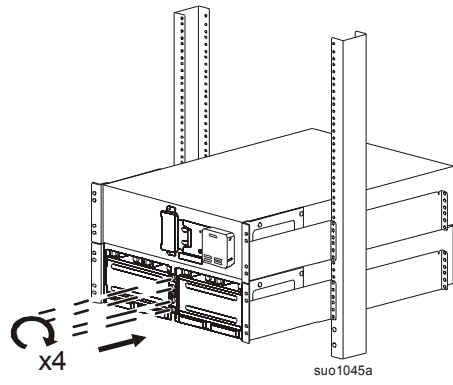

6

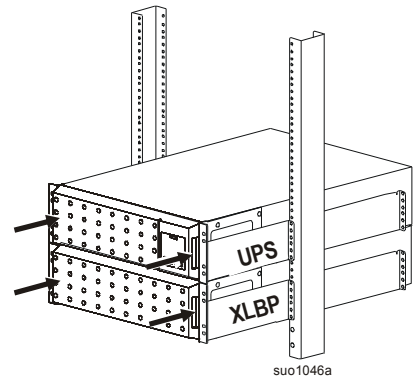

SRT8K/SRT10K UPS

CAUTION

DAMAGE TO EQUIPMENT OR PERSONNEL

- The equipment is heavy. Each APCRBC140 battery module weighs 17 kg (37 lb).
- Always practice safe lifting techniques adequate for the weight of the equipment.
- Remove the battery modules before installing the UPS.
- Use the battery module handle to carefully slide the battery module in or out of the unit.
- Do not use the battery module handle to lift or carry the battery module.
- Place the UPS on a table to remove the stabilizer brackets.
- Always install the UPS at the bottom of the rack.
- Always install the XLBP below the UPS in the rack.

Failure to follow these instructions can result in equipment damage and minor or moderate injury.

Tower to rack-mount conversion

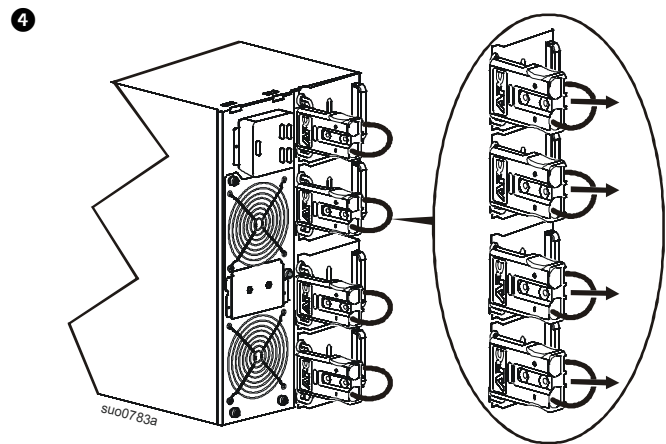
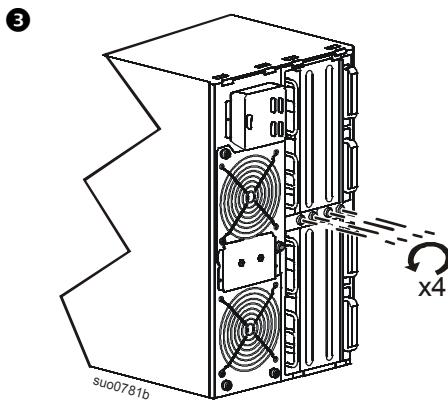
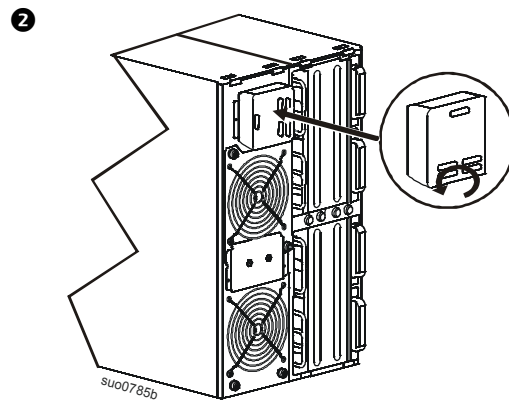
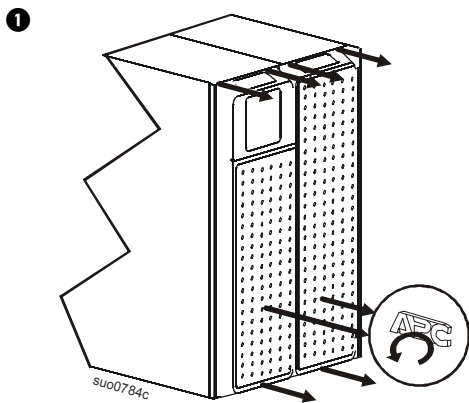

5

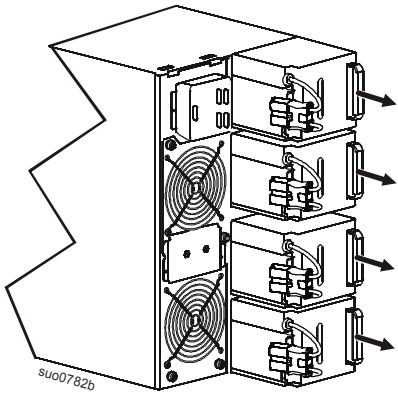

Install the SRT8K/SRT10K UPS in a rack

See “Install Rails to 2-Post Rack” on page 2 for instructions on rail installation.

1

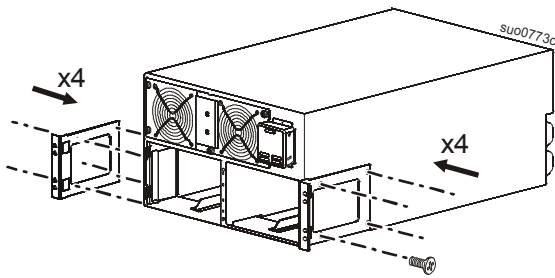

2

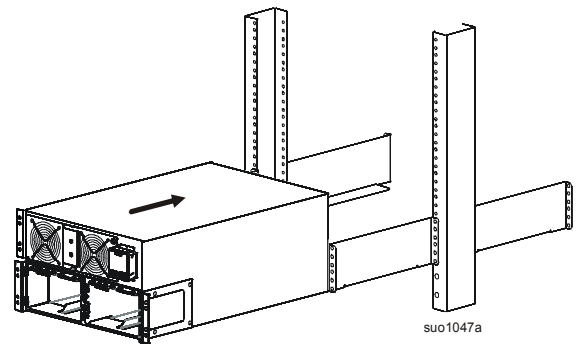

3

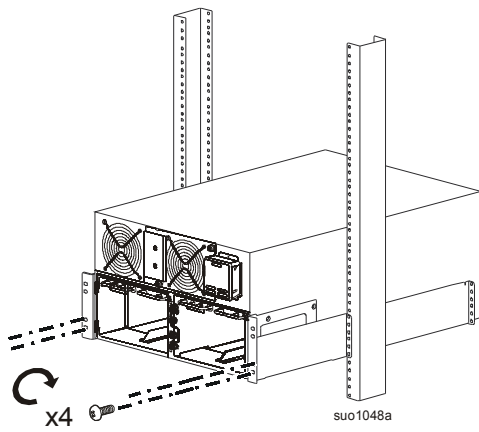

4

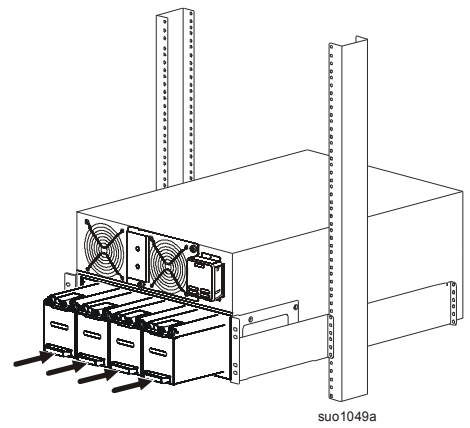

5

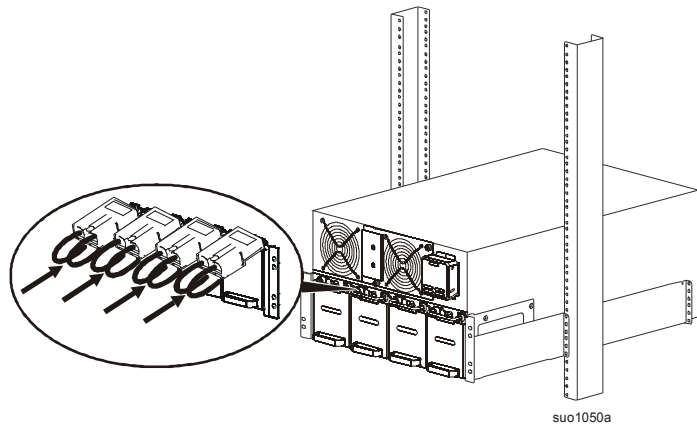

6

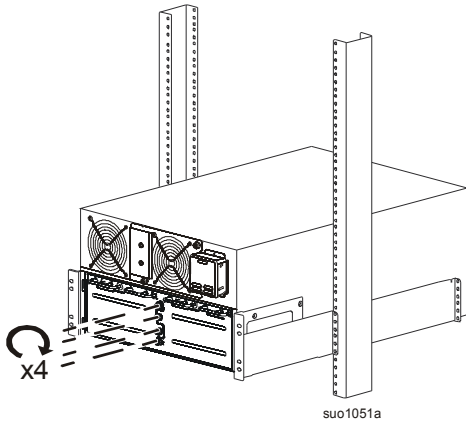

7

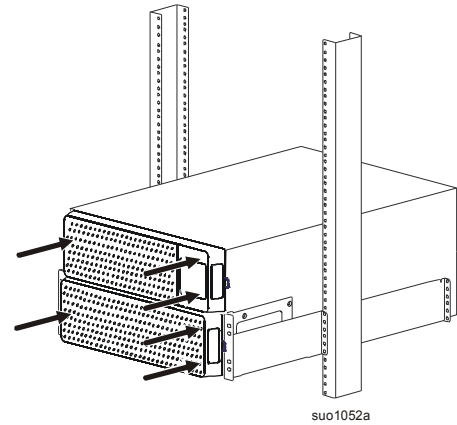

Install the SRT8K/SRT10K UPS with one external battery pack in a rack

The process for installation of an external battery pack with UPS models SRT8K/SRT10K models is identical to that described for the SRT5K/SRT6K models.

Refer to the installation process “Install the SRT5K/SRT6K UPS with one external battery pack in a rack” on page 12.

Customer support and warranty information is available at the APC by Schneider Electric web site, www.apc.com.