

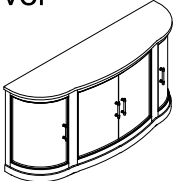





# ASSEMBLY INSTRUCTION

## SERVER

<b>A</b> Server  1 pc	<b>B</b> Front Leg  3 pcs	<b>C</b> Rear Leg  2 pcs	<b>D</b> Bolt 5/16" x 2-1/4"  10 pcs
<b>E</b> Lock Washer 5/16"  10 pcs	<b>F</b> Flat Washer 5/16"  10 pcs	<b>G</b> Allen Wrench 1/6"  1 pc	<b>H</b> Anti-Tipping Kit  1 set

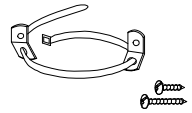
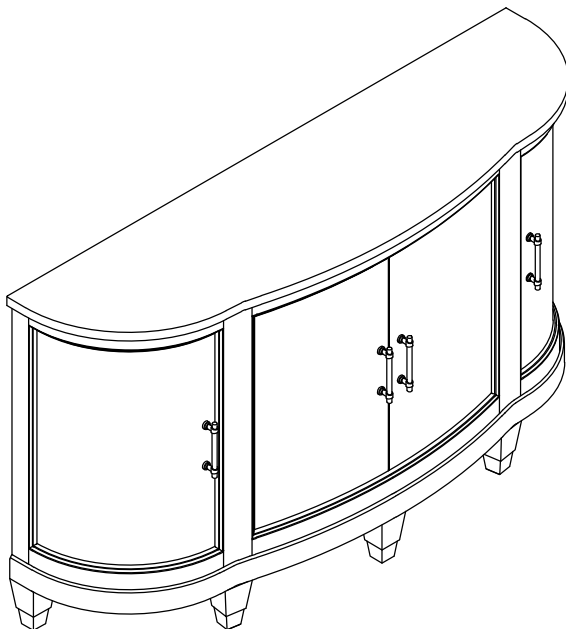

This page lists all the contents included in the box. Please take the time to identify the hardware as well as the individual components to this product. As you unpack and prepare for assembly, place the contents on a carpeted or padded area to protect them from damage.

**1**

Place the Server (A) on the ground. Tighten the Server (A) and Front Leg (B) and Rear Leg (C) by Bolt (D), Lock Washer (E) and Flat Washer (F) with Allen Wrench (G).

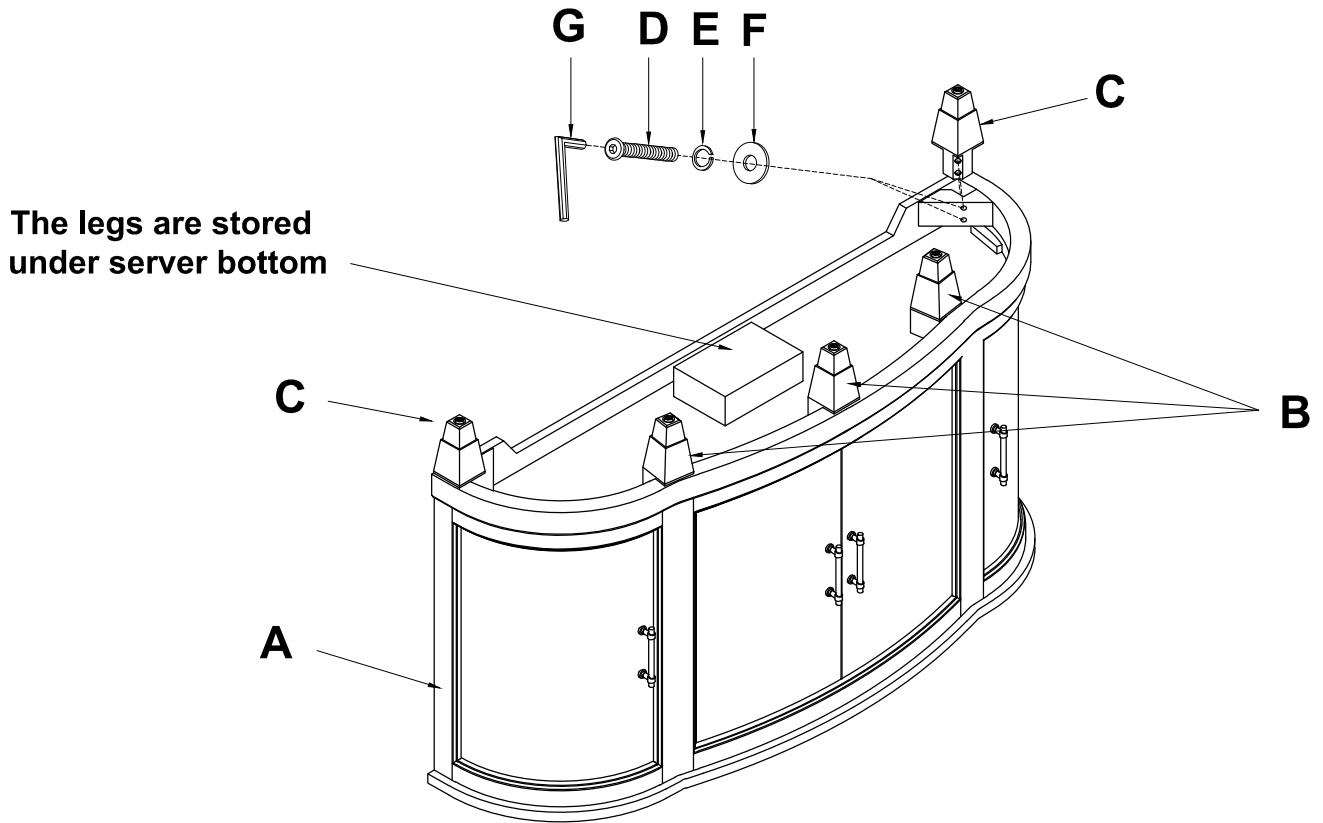

## 2

### PARTS IDENTIFICATION

#1 SERVER 1 PC

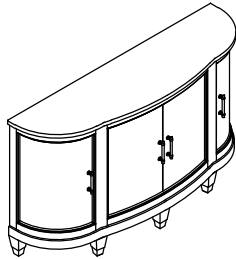

### HARDWARE IDENTIFICATION

#A		STRAP	1 PC
#B		BRACKET	2 PCS
#C		5 / 8" SCREW	1 PC
#D		2" SCREW	1 PC

This Anti-Tipping (H) must be attached to a wall stud using the 2" Screw (#D) enclosed.

1. Attach a Bracket (#B) securely to the back top rail of the Server (#1) using the 5/8" Screw (#C) provided through the smaller hole.
2. Locate the other Bracket (#B) on the wall over a wall stud and 2 inches below the mounting bracket secured to the back of your unit. Attach to the wall stud using the 2" Screw (#D) provided through the smaller hole.
3. Place the furniture into position so both mounting Bracket (#B) are vertically in line.
4. Lace the end of the restraint Strap (#A) through the larger hole in each mounting bracket. Bring both ends together and slide the flat end through the locking end and draw it through until all slack is removed.
5. Confirm that the Strap (#A) is securely laced and locked.

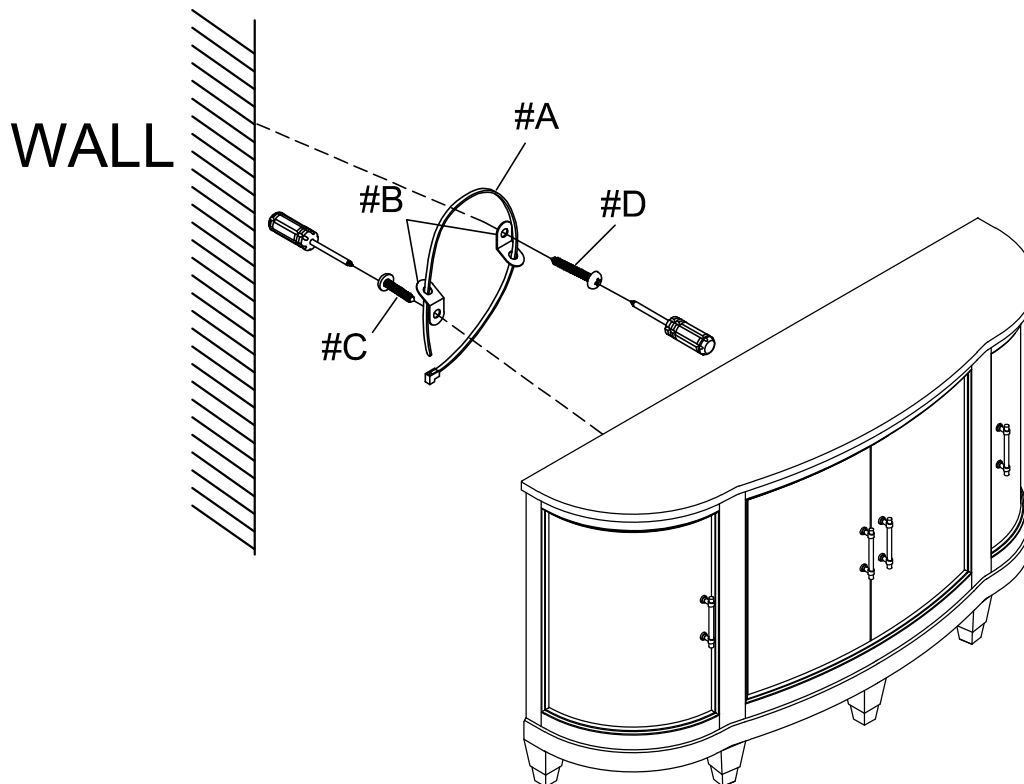

### Cleaning & Care

Treat surface with care. Surface is resistant to scratches but is not scratch resistant. Clean surfaces with a dry or damp soft cloth. Do not use abrasive cleaners. Hardware may loosen over time. Periodically check that all connections are tight.