

Product Specifications

2.5 Gallon Screw Top ST3 Pail with Cover

Note: *UN Solids rated to Y12.2/S

Multiple Uses

Dry Products

Product Codes

Pail: **9900 Series**

Description: 2.5 Gallon Screw Top Pail

Cover: **8900 Series**

Description: 2.0 - 2.5 Gallon Screw Top Cover

Features

Gauge: 80 mil

Nominal capacity: 2.5 USG / 9.5 L

Stack performance: 350 lbs.*

Tare weights: Body: 1.58 lbs. / 720 gr.

Cover: .39 lbs. / 179 gr.

Note: *Ratings will be reduced with uneven load distribution.

Specifications with Cover

Dimensions: 12 5/8" D. X 11 1/4" H

Maximum capacity: 2.8 USG / 10.6 L

Tare weight: 1.97 lbs. / .89 kgs.

Colors

Standard: White, Black and Natural

Custom: Available at manufacturer's discretion

Decorating Options

Four color offset printing

Print area: 27"W X 5-3/4"H

Sleeve or pressure sensitive labeling

Shipping Data

Qty. per pallet/carton:

Bodies

600*

Covers

1,800*

Filled Containers

36 (12 per layer/3 layers high)

Pallet height: 33.75"

Gross Weight (lbs/kgs.)**:

948/430

702/318.4

Length (in./cm.):

52/132

51.25/130.2

Width (in./cm.):

41.6/106

41/104.1

Height (in./cm.):

95.3/242

107/271.8

Approximate truckload quantity of 10,800 pails and covers***

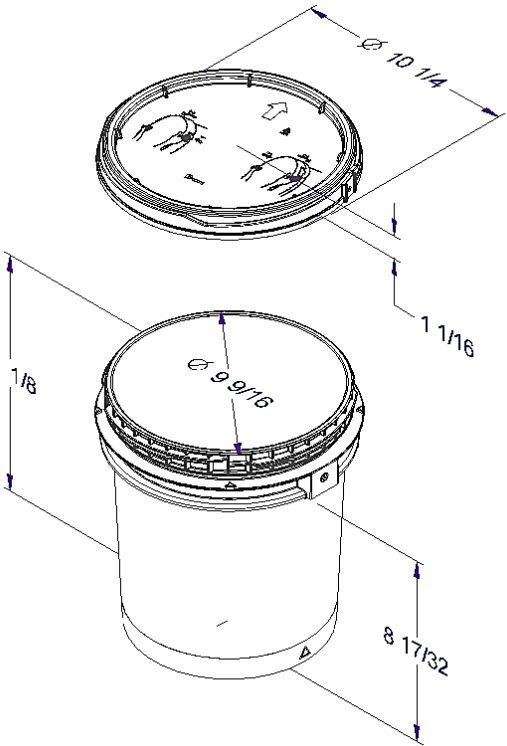

Notes:

*Quantity can vary based on customer request

**Weight does not include pallet/packaging

***Based on 53' trailer and full pallet quantities

Materials

FDA approved materials

Resin: Body: High-Density Polyethylene (HDPE)

Cover: High-Density Polyethylene (HDPE)

MSDS Sheets available upon request

Carrying Handle – Plastic

DISTRIBUTED BY:



REF NO.:

DWG30552

DESCRIPTION:

HDPE UN Rated Screw Top Cover for 2.5 Gallon Pails

DISCLAIMER

THIS INFORMATION IS PROVIDED AS A GENERAL GUIDE, INCLUDING DIMENSIONS. IT IS THE CUSTOMER'S RESPONSIBILITIES TO SELECT THE PROPER CONTAINER FOR PRODUCT AND APPLICATION COMPATIBILITY.