

# 5.0 Gallon Rectangular Tight Head with Swing Handle

## Product Uses

Liquid Products

## Product Codes

Container: RTH Series (HO)

Description: 5.0G Rectangular Tighthead

## Features

UN Rating: 3H1/Y1.8/100

Nominal capacity: 5.0 USG / 18.9L

Maximum capacity: 5.25 USG / 19.9 L

Tare weights: 2.59 lbs. / 1.175 kgs

## Colors

Standard: White, Black, Blue and Natural

Custom: Available at manufacturer's discretion

## Decorating Options

Maximum Label Area:

Perimeter: 38-1/4" x 8-3/16" H

See Salesperson for Options

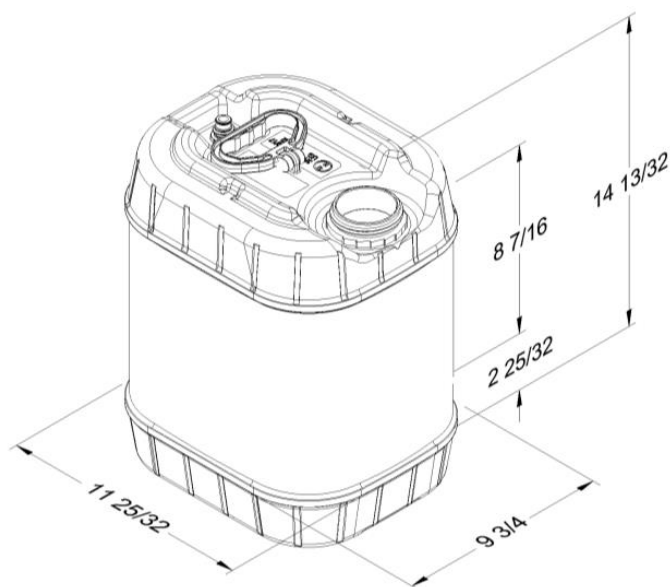

## Shipping Data

Qty. per floor spot:

Gross Weight (lbs./kgs)\*:

Length (in./cm.):

Width (in./cm.):

Height (in./cm.):

## Containers

112

352 / 159

48 / 121

35.3 / 90

103.5/262.9

## Filled Containers

Refer to BWAY document # ETS-CD-1002 for storage and shipping recommendations.

Estimated truckload quantity of 3,360 containers\*\*

Notes: \*Weight does not include pallet / packaging  
\*\*Truckload quantity based on 53' trailer

## Materials

FDA approved materials

Resin: Body: High-Density Polyethylene (HDPE)

Handle/Pin: High-Density Polyethylene (HDPE)

## Optional Carrying Handle

Swing Handle with Pin

DISTRIBUTED BY:



REF NO.:

DWG20428

DESCRIPTION:

5 Gallon HDPE Square Tight Head, 70 mm Dust Cap

## DISCLAIMER

THIS INFORMATION IS PROVIDED AS A GENERAL GUIDE, INCLUDING DIMENSIONS. IT IS THE CUSTOMER'S RESPONSIBILITIES TO SELECT THE PROPER CONTAINER FOR PRODUCT AND APPLICATION COMPATIBILITY.