











HEKMAN®

X A HOWARD MILLER COMPANY

24805 CHAIRSIDE TABLE

HARDWARE LIST					
A	B	C	D	E	
ALLEN BOLT M6 X 40 (4 PCS.)	ALLEN BOLT M6 X 60 (4 PCS.)	FLAT W. M6 8 PCS.	LOCK W. M6 8 PCS.	ALLEN KEY L4 (FOR ALLEN BOLT) 1 PC.	
					

PART INSIDE			
1 TOP ASSEMBLY (1 Pc)	2 BASE ASSEMBLY (1 Pc)	3 METAL LEG X (1 Pc)	4 METAL LEG Y (2 Pcs)
			

STEP 1.

Assembly Instruction

PLACE CHAIRSIDE TABLE TOP ASSEMBLY ON A SOFT AND FLAT SURFACE. ASSEMBLE THE METAL LEG X (3) AND METAL LEG Y (4) TO THE BOTTOM OF THE TOP ASSEMBLY USING THE PROVIDED ALLEN BOLT (A), LOCK WASHER (D), FLAT WASHER (C) AND ALLEN KEY (E).

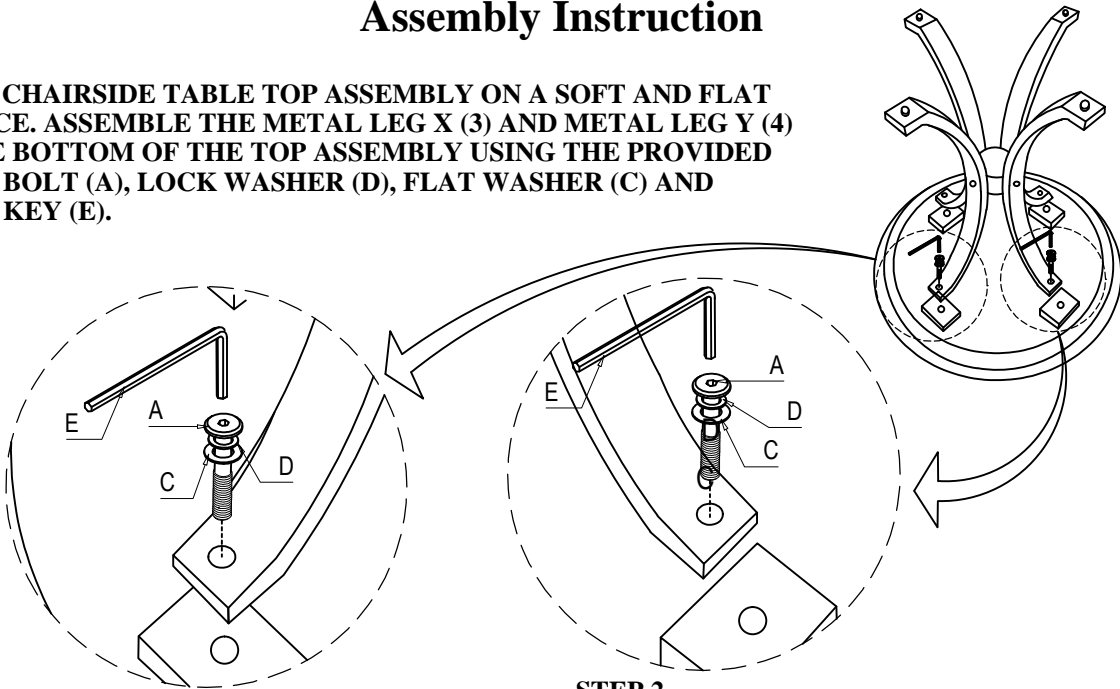

STEP 2.

INSTALL BASE ASSEMBLY (2) TO THE METAL LEG X (3) AND METAL LEG Y (4) USING THE PROVIDED ALLEN BOLT (B), LOCK WASHER (D), FLAT WASHER (C) AND ALLEN KEY (E). TIGHTEN ALL.

