

RSDS-M

Surface Mount Downlight with PIR Motion Sensor

Product Description

The RSDS-M Surface Mount Downlight with PIR Motion Sensor offers a thin installation solution that provides automatic on/off control. Select the CCT (3000/4000/5000K) with the flip of a switch. Installation is easier than ever with the twist lock diffuser that can be removed for installation. The direct box mount ensure it sits flush to the ceiling for a clean and professional look. Perfect for bringing even illumination with automatic controls to closets, pantries, and similar areas.

Construction

- Durable aluminum body
- Twist-lock diffuser allows for easy removal during installation

Optical System

- Molded polymer, UV stabilized diffuser maximizes light output.
- Convex diffuser creates uniform light distribution while reducing glare
- Offered in 3 CCT selection of 3000K, 4000K, and 5000K

Electrical

- Input voltage of 120VAC, 60Hz
- CCT switch located on back of fixture
- Integrated PIR motion sensor. Automatic ON with 30 second wait time to OFF.
- Dimmable to 5% with compatible leading edge (TRIAC) and trailing edge (ELV) dimmers
- Operating temperature rating of -4°F to 104°F (-20°C to 40°C)

Finish

- White powder coat finish standard

Mounting and Installation

- Easy installation in any 4" pancake, 4" non-metallic or 4/O junction box
- Keyhole mounting slots allow for quick installation to junction boxes
- For installations where power surge may be possible, NICOR recommends installing additional surge protection at the electrical distribution panel

Listings

- cETLus 1598 Listed for wet locations
- ENERGYSTAR Listed
- CA Title 24/JA8 Compliant
- Compliant with NFPA® 70, NEC® Section 410.16 (A)(3) and 410.16 (C)(5) for closet use
- RoHS Compliant
- Meets FCC Part 15, Subpart B, Class B standards for conducted and radiated emissions
- TM-21 Reported L70(9k) life >54,000 hours
- LM-79, LM-80 testing performed in accordance with IESNA standards

Warranty

- 5-year limited system warranty standard
- Warranty does not cover product failure due to an overvoltage event (power surge)

Project

Catalog

Type

Date

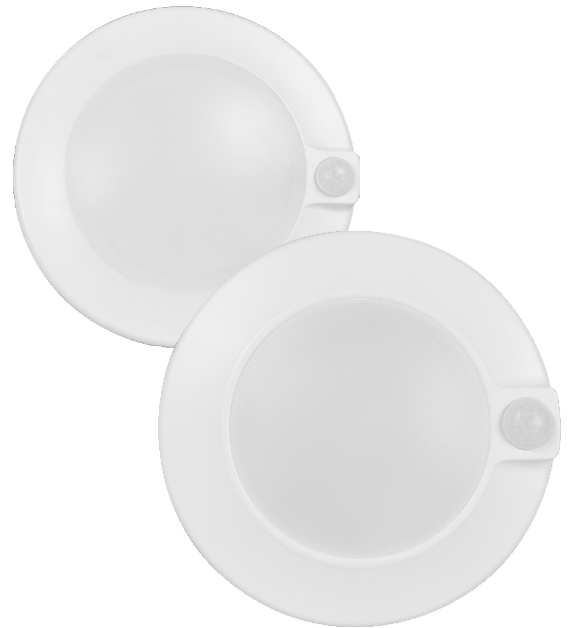

RSDS-M 4", 6" Surface Mount Downlight with PIR Motion Sensor 600, 800 lumen



Ordering

Ordering Information

Example: RSD6120SWHM

Series	Version	Voltage	CCT's	Trim Color	Sensor
RSD4	1	120	S (Selectable 3000/4000/5000K)	WH (White)	M (PIR sensor)
RSD6					

Specifications and dimensions subject to change without notice

Performance Data

Performance Data			
Model Number	Lumens	Watts	Lumens/Watt
RSD4SM-3000K	611	9.74	62.7
RSD4SM-4000K	658	9.71	67.8
RSD4SM-5000K	620	9.73	63.7
RSD6SM-3000K	832	14.46	57.5
RSD6SM-4000K	988	15.55	63.7
RSD6SM-5000K	856	14.61	58.6

Recommended Dimmers*

Lutron Diva DVCL-153P
 Lutron Maestro MACL-153M
 Eaton Cooper SLC03P
 Leviton IPL06
 Lutron DIVA DVELV-300P

*Not a complete list. Check compatibility before installation.

Housing Compatibility*

Most 4" Pancake, 4" Non-Metallic or 4/O junction boxes

Photometric Data

RSD4SM 3000K

Input Voltage (VAC)	120V
System Level Power (W)	9.8
Delivered Lumens (Lm)	611
System Efficacy (Lm/W)	62.3
Correlated Color Temp (K)	3005
Color Rendering Index (CRI)	91 R9=50
Beam Angle	109
Spacing Criteria	1.24

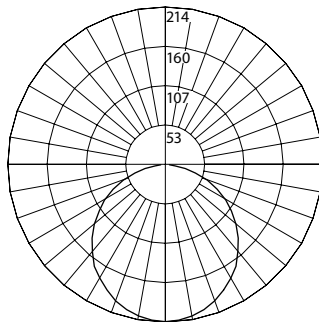

Intensity Summary (Candle Power)

Angle	Mean CP
0	213
5	211
15	204
25	187
35	164
45	136
55	105
65	74
75	43
85	19
90	9

Cone of Light Tabulation

Mounted height (Feet)	Footcandles Beam Center	Diameter (Feet)
4	13.3	11.2
6	5.9	16.8
8	3.3	22.3
10	2.1	27.9

Zonal Lumen Summary

Zone	Lumens	% of Luminaire
0-30	163	26.7%
0-40	265	43.4%
0-60	462	75.7%
0-90	511	100%
90-180	0	0%
0-180	611	100%

Fixture tested per LM-79-08. Photometric data is of the performance of a representative fixture. Results may vary in the field.

RSD6SM 3000K

Input Voltage (VAC)	120V
System Level Power (W)	14.5
Delivered Lumens (Lm)	832
System Efficacy (Lm/W)	57.4
Correlated Color Temp (K)	3057
Color Rendering Index (CRI)	92 R9=54
Beam Angle	113
Spacing Criteria	1.26

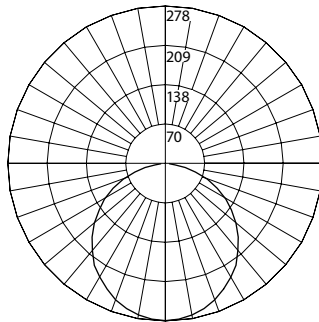

Intensity Summary (Candle Power)

Angle	Mean CP
0	277
5	275
15	265
25	244
35	217
45	183
55	143
65	100
75	58
85	24
90	9

Cone of Light Tabulation

Mounted height (Feet)	Footcandles Beam Center	Diameter (Feet)
4	17.3	12.1
6	7.7	18.2
8	4.3	24.2
10	2.8	30.3

Zonal Lumen Summary

Zone	Lumens	% of Luminaire
0-30	215	25.8%
0-40	352	42.3%
0-60	626	75.2%
0-90	832	100%
90-180	0	0%
0-180	832	100%

Fixture tested per LM-79-08. Photometric data is of the performance of a representative fixture. Results may vary in the field.

Dimensions and Sensor Information

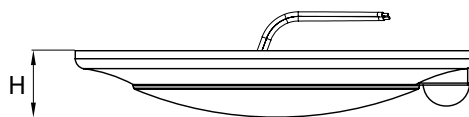
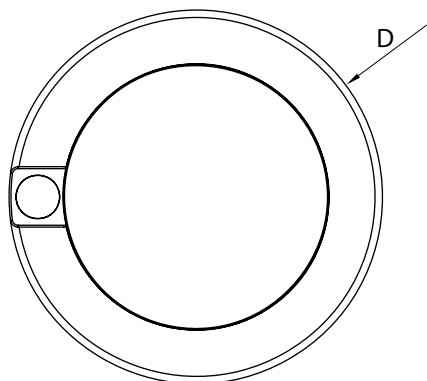

Dimensions		
Fixture	Diameter (D)	Height (H)
RSD4SM	6.9" (175mm)	1.1" (28mm)
RSD6SM	7.9" (201mm)	1.3" (33mm)

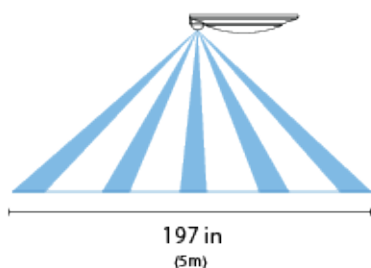

Ceiling Mount Sensor Detection Range

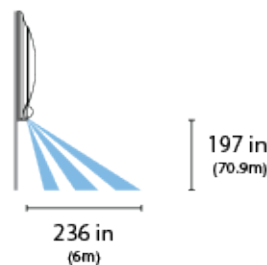

SIDE VIEW

This device complies with part 15 of the FCC Rules. Operation is subject to the following two conditions: (1) This device may not cause harmful interference, and (2) this device must accept any interference received, including interference that may cause undesired operation. NOTE: This equipment has been tested and found to comply with the limits for a Class B digital device, pursuant to part 15 of the FCC Rules. These limits are designed to provide reasonable protection against harmful interference in a residential installation. This equipment generates, uses and can radiate radio frequency energy and, if not installed and used in accordance with the instructions, may cause harmful interference to radio communications. However, there is no guarantee that interference will not occur in a particular installation. If this equipment does cause harmful interference to radio or television reception, which can be determined by turning the equipment off and on, the user is encouraged to try to correct the interference by one or more of the following measures:

- Reorient or relocate the receiving antenna.
- Increase the separation between the equipment and receiver.
- Connect the equipment into an outlet on a circuit different from that to which the receiver is connected.
- Consult the dealer or an experienced radio/TV technician for help.