

Product Specifications

5.0 Gallon Delex Tight Head with 2" Internal Buttress Thread

Product Uses

Liquid Products

Product Codes

Container: **Delex Tighthhead**

Bung Closure Options: 2" Buttress Plug & Gasket

2" NPS Plug & Gasket

Features

UN Rating(No Vent): 3H1/Y1.9/150

UN Rating(With Vent): 3H1/Y1.4/100

Nominal capacity: 5.0 USG / 18.9L

Maximum capacity: 5.3 USG / 20.1 L

Tare weights: 2.86 lbs / 1.3 kgs

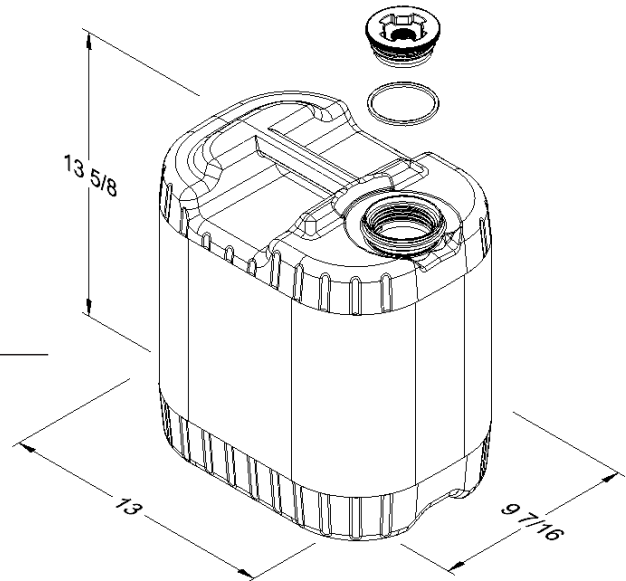

Colors

Standard: White, Black, Blue and Natural

Custom: Available at manufacturer's discretion

Decorating Options

Maximum Label Area: 6" x 7"

See Salesperson for Options

Shipping Data

Qty. per floor spot:

105

Gross Weight (lbs./kgs)*:

296 / 135

Length (in./cm.):

47 / 118

Width (in./cm.):

35.4 / 90

Height (in./cm.):

102 / 260

Containers

Estimated truckload quantity of 3,150 containers**

Notes: *Weight does not include pallet / packaging

**Truckload quantity based on 53' trailer

Materials

FDA approved materials

Resin: Body: High-Density Polyethylene (HDPE)

Bung Closure installed during manufacturing

MSDS Sheets available upon request

Optional Carrying Handle

Integral

DISTRIBUTED BY:



REF NO.:

DWG30582

DESCRIPTION:

5 Gallon HDPE Square TH with 2 in Thread Buttress (Delex)

DISCLAIMER

THIS INFORMATION IS PROVIDED AS A GENERAL GUIDE, INCLUDING DIMENSIONS. IT IS THE CUSTOMER'S RESPONSIBILITIES TO SELECT THE PROPER CONTAINER FOR PRODUCT AND APPLICATION COMPATIBILITY.