

DETAIL A
SCALE 3/4

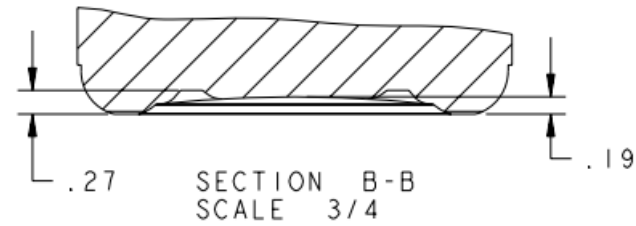

SECTION B-B
SCALE 3/4

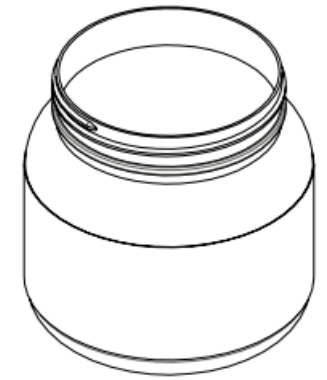
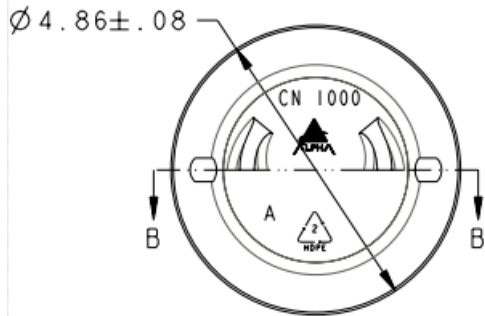

	Min Thk	Color	Weight	Std. Pack
All measurements are in inches	.015	All Colors	55 Gms±3.5	120, Stack
Neck Dimensions:				
T = 3.920±.018				
E = 3.800±.018				
H = .597±.015				
I = 3.344 MIN				
S = .060±.015				
Overflow Capacity: 1200 ml ± 20				

DISCLAIMER

THIS INFORMATION IS PROVIDED AS A GENERAL GUIDE, INCLUDING DIMENSIONS. IT IS THE CUSTOMER'S RESPONSIBILITIES TO SELECT THE PROPER CONTAINER FOR PRODUCT AND APPLICATION COMPATIBILITY.

DISTRIBUTED BY:



REF NO.:

DWG30787

DESCRIPTION:

1000 cc HDPE Packer, 100-400