

Hazardous area LED lighting
Vaporgard™ LED Luminaires

CROUSE-HINDS
SERIES

Vaporgard™ LED

Low profile LED downlight



EATON

Powering Business Worldwide

Vaporgard LED Lighting

Safe. Reliable. Efficient.

Eaton's Crouse-Hinds offers the broadest portfolio of LED luminaires for any industrial or hazardous application.

We utilize more than 100 years of lighting expertise to maximize the benefits of LED technology to provide **safe and reliable LED luminaires for hazardous areas.**

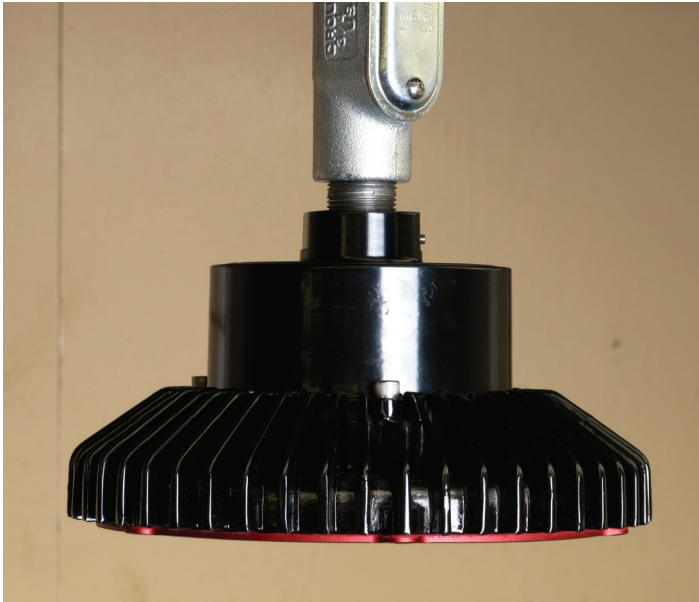

Why LED?

Useful Life

- Rated life is up to 60,000 hours of maintenance-free and safe operation

Energy efficiency

- LEDs use 90% less energy than incandescent

Start/restart time

- Instant illumination compared to 10 minute restrike time for HID

Light quality

- Higher color rendering and color temperature

Environmental benefits

- LED reduces carbon footprint
- Mercury-free

Why Crouse-Hinds?

Industry-best reliability

- Built to withstand extreme temperatures, vibration, water and dust

Thermal management

- Effective heat sinking ensures longer life

Retrofit compatibility

- LED fixtures are compatible with Crouse-Hinds' Vaporgard incandescent installed base

Why Vaporgard LED?



- 20X the life of incandescent lamps



- 50% lower profile than incandescent luminaires

Application

Challenge:

You're faced with high energy and maintenance costs related to your current incandescent lighting fixtures. You need a solution which will not only reduce operating expenses, but also replace your current incandescent fixtures.

Old way:

Replace your current incandescent fixtures with a higher wattage HID luminaire. Light output has increased, however, energy costs have gone up 30%, maintenance costs are still an issue, and future regulations may require another change.

New way:

Install Vaporgard LED luminaires reduce energy consumption and maintenance costs associated with lamp replacement. The Vaporgard LED is designed to easily adapt to existing mounting modules for ease of installation. That, along with a 20 times longer life, makes Vaporgard LED an ideal replacement.

Benefit:

Realize 90% energy savings and eliminate maintenance by installing Vaporgard. Qualify for rebate incentives with local municipalities and federal programs. Take advantage of the robust, low profile design by installing in those hard to reach locations.



Design features



EASY INSTALLATION AND REPLACEMENT

- Contractor-friendly design is ideal for both retrofit and new construction applications
- Installed using the same wall and ceiling mounts as incandescent Vaporgard fixtures

LOW PROFILE DESIGN

- Unique domeless, low profile design for low mounting heights and confined spaces where incandescent and HID based luminaires are too large to fit in the mechanical envelope required

MULTIPLE LENS OPTIONS

- Tempered clear glass lens standard
- Diffused glass lens and teflon coated lens options available

MODULAR DESIGN

- Compact and modular design allows for easy component replacement and future upgrades



RUGGED HEAT SINK

- Heat sink designed to perform in high ambient temperatures up to +55°C and as low as -30°C
- Thick walled castings make for a tough, rugged housing that keeps the internal driver and LED temperature down



Features & benefits

Vaporgard LED

Cool white color temperature – 5000K

Provides uniform crisp, white light and is suitable for lower mounting heights, confined spaces, tunnels or utility rooms. This fixture can deliver similar light levels to 50 watt HID.

Warm white color temperature – 3000K

Provides similar benefits as the cool white version, but with a color rendering more consistent with a warm incandescent or HPS lamp source.

Available with DC power supply

For applications with DC power requirements such as solar, battery or UPS. The DC power supply is suitable for 10 VDC through 30 VDC.



V2LC

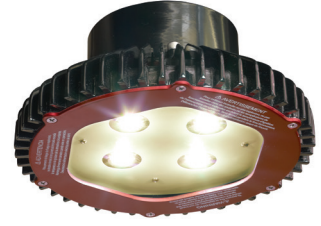

V2LW

Benefits:

Enhance safety and productivity

- Instant illumination and re-strike
- Cold temperature operation; no warm-up time
- Lightweight, low profile and cool surface temperatures
- Driver with internal fusing for branch circuit protection

Reduce operation and maintenance costs

- High efficacy LEDs can save up to 90% in energy costs
- No mercury or hazardous chemicals - eliminates disposal concerns
- Mounts to existing Vaporgard mounting modules

Reliable performance in any environment

- Shock- and vibration-resistant
- Teflon coated lens (suffix S896) option for increased safety in food processing facilities
- Operating ambient:
 - V2L: -30°C to +55°C
 - V3L: -30°C to +55°C

Applications:

- Oil and gas refineries, drilling rigs, petrochemical facilities, food and beverage facilities, platforms, loading docks, tunnels, outdoor wall and stanchion mounted general area lighting, and where flammable vapors, gases, ignitable dusts, fibers or flyings are present
- Locations requiring continuous and consistent light levels in extreme ambient temperatures
- Where extremely corrosive, wet, dusty, hot and/or cold conditions exist
- Type 4X, marine, wet locations and hose-down environments
- Confined space or low ceiling areas, such as tunnels, utility rooms, over doorways, entries, landings, etc.
- Areas requiring frequent on/off of lights
- Areas where maintenance is difficult or challenging
- Areas requiring shatter-protected products, such as food processing facilities
- Outdoor wall or ceiling mounted area illumination
- Low mounting heights
- Classified and hazardous locations

Model number	Nominal lumens	Wattage	Equivalent incandescent luminaire	Typical energy savings/lifetime
V2LM2C/UNV1	1,772	14	50W HID or 150-200W incandescent	90% energy savings and 50,000 hours of 24/7 operation!
V3LM2C/UNV1	3,335	29		



Specifications

Certifications and compliances:

NEC and CEC

- Class I, Division 2, Groups A, B, C, D
- Class II, Divisions 1 & 2, Groups F, G*
*mounting options limited

UL Standards

- UL844; UL1598; UL1598A

CSA Standard

- CSA C22.2 No. 137
- NEMA 4X
- IP66

IEC

- IEC 60079-0:2011; IEC 60079-31:2013; IEC 60079-7:2017
- V2LM2/UNIV1: Ex ec IIC T5 Gc; Ex tc IIIB T62°C Dc IP66
- V2LM2/DC1: Ex ec IIC T6 Gc; Ex tc IIIB T50°C Dc IP66
- V3LM2/UNIV1: Ex ec IIC T4 Gc; Ex tc IIIB T69°C Dc IP66
- V3LM2/DC1: Ex ec IIC T5 Gc; Ex tc IIIB T60°C Dc IP66

ATEX

- EN 60079-0: 2012+A11:2013; EN 60079-7: 2015 +A1:2018; EN 60079-31:2014
- V2LM2/UNV1:
⊕II 3 G Ex ec IIC T5 Gc; ⊕II 3 D Ex tc IIIB T62°C Dc IP66
- V2LM2/DC1:
⊕II 3 G Ex ec IIC T6 Gc; ⊕II 3 D Ex tc IIIB T50°C Dc IP66
- V3LM2/UNV1:
⊕II 3 G Ex ec IIC T4 Gc; ⊕II 3 D Ex tc IIIB T69°C Dc IP66
- V3LM2/DC1:
⊕II 3 G Ex ec IIC T5 Gc; ⊕II 3 D Ex tc IIIB T60°C Dc IP66

Electrical ratings:

	120-277VAC input		10-30 VDC input	
	Power	Current	Power	Current
V2LM2	14W	.12A	14W	1.4A
V3LM2	29W	.24A	31W	3.0A

5 year limited warranty. Refer to the authorized distributor price book for Crouse-Hinds standard Terms and Conditions.

Temperature ratings:

UNV1	Ambient temperature	Class I, Div. 2	Class I, Division 2	Class III, Div. 1
V2LM2	40°C	T5	T5	T5
	55°C			
V3LM2	40°C	T4	T4	T4
	55°C			

DC1	Ambient temperature	Class I, Div. 2	Class I, Division 2	Class III, Div. 1
V2LM2	40°C	T5	T5	T5
V3LM2	40°C	T6	T6	T6

Weights:

Model number	Lbs.	kg.
Pendant mount	5.7	2.59
Ceiling mount	6.8	3.08
Wall mount	7.9	3.58
Stanchion mount	6.5	2.95



Standard materials:

- Body and mounting modules – copper-free aluminum with Corro-free™ epoxy powder coat
- Lens bezel – aluminum with anodized finish
- Lens – heat- and impact-resistant glass
- Gaskets – silicone
- External hardware – stainless steel

LED driver:

- Constant current regulated power supply
- 120-277VAC, 50/60 Hz
- Power factor: >0.9
- Low harmonic distortion: <20%
- Low in-rush current, <20 amps
- EMC compliant to 47CFR, Part 2, Part 15
- 10-30 VDC option available

LED system:

- (4) High brightness LED arrays
- Cool white (5000K), CRI 70
- Warm white (3000K), CRI 82
- Neutral white (4000K), 80 CRI
- L70 >60,000 hours

Ordering information

Part number example

V2LM2CHBF1/UNV1 S891

Vaporgard LED, rated for hazardous areas, 1,772 lumens, Cool white (5000K), 70 CRI, wall mount with junction box, 120-277 VAC, 50/60 Hz. diffused glass lens

<p>V</p> <p>Series</p> <table border="1"> <tr> <td>V</td> <td>Hazardous area rated</td> </tr> </table> <p>Lumen level (nominal)</p> <table border="1"> <tr> <td>2LM2</td> <td>1,772 lumen LED</td> </tr> <tr> <td>3LM2</td> <td>3,335 lumen LED</td> </tr> </table> <p>Color temperature</p> <table border="1"> <tr> <td>C</td> <td>Cool (5000K), 70 CRI min.</td> </tr> <tr> <td>N</td> <td>Neutral (4000K), 80 CRI min.</td> </tr> <tr> <td>W</td> <td>Warm (3000K), 80 CRI min.</td> </tr> </table> <p><small>*Consult factory for availability on neutral color temperature.</small></p>	V	Hazardous area rated	2LM2	1,772 lumen LED	3LM2	3,335 lumen LED	C	Cool (5000K), 70 CRI min.	N	Neutral (4000K), 80 CRI min.	W	Warm (3000K), 80 CRI min.	<p>2LM2</p>	<p>C</p> <p>Mounting modules Class I, Division 2; Class II, Division 1, Groups F&G</p> <table border="1"> <tr> <td>A</td> <td>VLA – pendant mount</td> </tr> <tr> <td>HJ</td> <td>VXJ – stanchion mount</td> </tr> <tr> <td>HW*</td> <td>VXW – wall mount</td> </tr> </table> <p><small>*Mounts directly to the wall, no VXFT junction box needed.</small></p> <p style="text-align: center;">OR</p> <p>Class I, Division 2; Class II, Division 2, Groups F&G</p> <table border="1"> <tr> <td>BLANK</td> <td>LED housing only (warehouse/spare parts)</td> </tr> <tr> <td>HBF</td> <td>VXT – wall mount with VXFT junction box</td> </tr> <tr> <td>HF</td> <td>VXF – junction box for ceiling mount</td> </tr> <tr> <td>HR</td> <td>VLHR – adapter cover (for retrofit)</td> </tr> <tr> <td>HT</td> <td>VXT – wall mount</td> </tr> </table>	A	VLA – pendant mount	HJ	VXJ – stanchion mount	HW*	VXW – wall mount	BLANK	LED housing only (warehouse/spare parts)	HBF	VXT – wall mount with VXFT junction box	HF	VXF – junction box for ceiling mount	HR	VLHR – adapter cover (for retrofit)	HT	VXT – wall mount	<p>1</p> <p>Hub size</p> <table border="1"> <tr> <td>BLANK</td> <td>No hub (LED housing, adapter)</td> </tr> <tr> <td>1</td> <td>½" NPT (pendant, ceiling, wall)</td> </tr> <tr> <td>2</td> <td>¾" NPT (pendant, ceiling, wall)</td> </tr> <tr> <td>3</td> <td>1" NPT (pendant)</td> </tr> <tr> <td>4</td> <td>1-¼" NPT (stanchion)</td> </tr> </table>	BLANK	No hub (LED housing, adapter)	1	½" NPT (pendant, ceiling, wall)	2	¾" NPT (pendant, ceiling, wall)	3	1" NPT (pendant)	4	1-¼" NPT (stanchion)	<p>UNV1</p> <p>Options</p> <table border="1"> <tr> <td>BLANK</td> <td>Clear glass lens</td> </tr> <tr> <td>S891</td> <td>Diffused glass lens</td> </tr> <tr> <td>S896</td> <td>Teflon coated lens</td> </tr> </table> <p>Voltage</p> <table border="1"> <tr> <td>UNV1</td> <td>120-277 VAC, 50/60 Hz;</td> </tr> <tr> <td>DC1*</td> <td>10-30 VDC</td> </tr> </table> <p><small>*Rated to +40°C</small></p>	BLANK	Clear glass lens	S891	Diffused glass lens	S896	Teflon coated lens	UNV1	120-277 VAC, 50/60 Hz;	DC1*	10-30 VDC	<p>S891</p>
V	Hazardous area rated																																																				
2LM2	1,772 lumen LED																																																				
3LM2	3,335 lumen LED																																																				
C	Cool (5000K), 70 CRI min.																																																				
N	Neutral (4000K), 80 CRI min.																																																				
W	Warm (3000K), 80 CRI min.																																																				
A	VLA – pendant mount																																																				
HJ	VXJ – stanchion mount																																																				
HW*	VXW – wall mount																																																				
BLANK	LED housing only (warehouse/spare parts)																																																				
HBF	VXT – wall mount with VXFT junction box																																																				
HF	VXF – junction box for ceiling mount																																																				
HR	VLHR – adapter cover (for retrofit)																																																				
HT	VXT – wall mount																																																				
BLANK	No hub (LED housing, adapter)																																																				
1	½" NPT (pendant, ceiling, wall)																																																				
2	¾" NPT (pendant, ceiling, wall)																																																				
3	1" NPT (pendant)																																																				
4	1-¼" NPT (stanchion)																																																				
BLANK	Clear glass lens																																																				
S891	Diffused glass lens																																																				
S896	Teflon coated lens																																																				
UNV1	120-277 VAC, 50/60 Hz;																																																				
DC1*	10-30 VDC																																																				

Accessories (ordered separately):

Replacement driver kits

V2LM2/P2LM2 350MA AC DRIVER KIT	Replacement 350MA AC driver kit
V2LM2/P2LM2 350MA DC DRIVER KIT	Replacement 350MA DC driver kit
V3LM2/P3LM2 700MA DC DRIVER KIT	Replacement 700MA DC driver kit

Dimensions

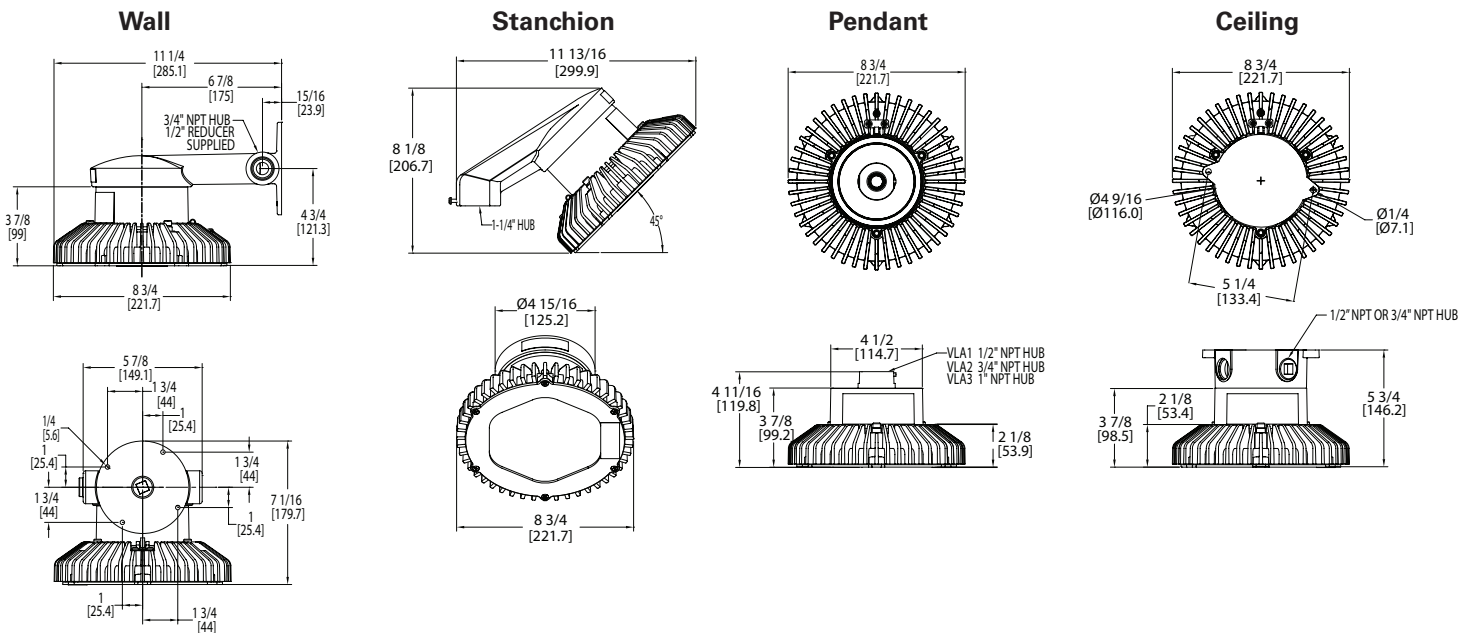

**U.S. (global headquarters):
Eaton's Crouse-Hinds business**

1201 Wolf Street
Syracuse, NY 13208

(866) 764-5454
FAX: (315) 477-5179
FAX Orders Only:
(866) 653-0640

crousecustomerctr@eaton.com

Eaton's B-Line business

509 West Monroe Street
Highland, IL 62249

800-851-7415
FAX: 618-654-1917

Eaton.com/b-lineseries

IEC Electrical
(CEAG products)

49 (0) 6271 806-500
FAX: 49 (0) 6271 806-476

Info-ex@eaton.com

Airport Lighting

866-764-5454

CrouseCustomerCTR@Eaton.com

Mexico/Latin America/Caribbean

52-555-804-4000
FAX: 52-555-804-4020

ventascentromex@eaton.com

Haz Area Communications
(MEDC, Hernis, Oxalis, FHF Sonix)

44 (0) 1623 444400
FAX: 44 (0) 1623 444531

MEDCadmin@Eaton.com

Canada

Toll Free: 800-265-0502
FAX: (800) 263-9504
FAX Orders only: (866) 653-0645

China

86-21-2899-3600
FAX: 86-21-2899-4055

echsales@eaton.com

Process instrumentation
(MTL products)

44 (0) 1582 723633
FAX: 44 (0) 1582 422283

enquiry@mtl-inst.com

Eaton Middle East

9714-8066100
FAX: 9714-8894813

CHBLME@eaton.com

Australia

61-2-8787-2777
FAX: 61-2-9609-2342

crousehindsanz@eaton.com

For more information:

If further assistance is required, please contact an authorized Eaton Distributor, Sales Office, or Customer Service Department.

Eaton's Crouse-Hinds
1201 Wolf Street
Syracuse, NY 13208
Crouse-Hinds.com

Eaton
1000 Eaton Boulevard
Cleveland, OH 44122
United States
Eaton.com

© 2024 Eaton
All Rights Reserved
Printed in USA
Publication No. BR403030EN
June 2024

Eaton is a registered trademark.

All other trademarks are property of their respective owners.

Follow us on social media to get the latest product and support information.

