

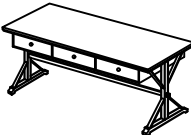





HEKMAN®

A HOWARD MILLER COMPANY

27535 WRITING DESK

Hardware List

A	B	C	D	E	F	
ALLEN BOLT M8 X 35 (6 PCS.)	FLAT W8 M8 6 PCS.	SPRING W. M8 6 PCS.	SCREW Ø8 X 2" (2 PCS.)	SCREW Ø6 X 1" (18 PCS.)	ALLEN KEY L5 (FOR ALLEN BOLT) 1 PC.	
						

Assembly Instruction

STEP 1.

LAY BODY TOP PANEL UPSIDE DOWN ON A SOFT, CLEAN AND FLAT SURFACE. ALIGN LEG TO HOLES ON TOP PANEL AND CONNECT USING FLAT WASHER (B), SPRING WASHER (C), ALLEN BOLT (A) AND ALLEN KEY (E) PROVIDED.

ALIGN AND FASTEN STRETCHER TO LEG USING SCREW (D) AND TIGHTEN WITH SCREW DRIVER (NOT INCLUDED)

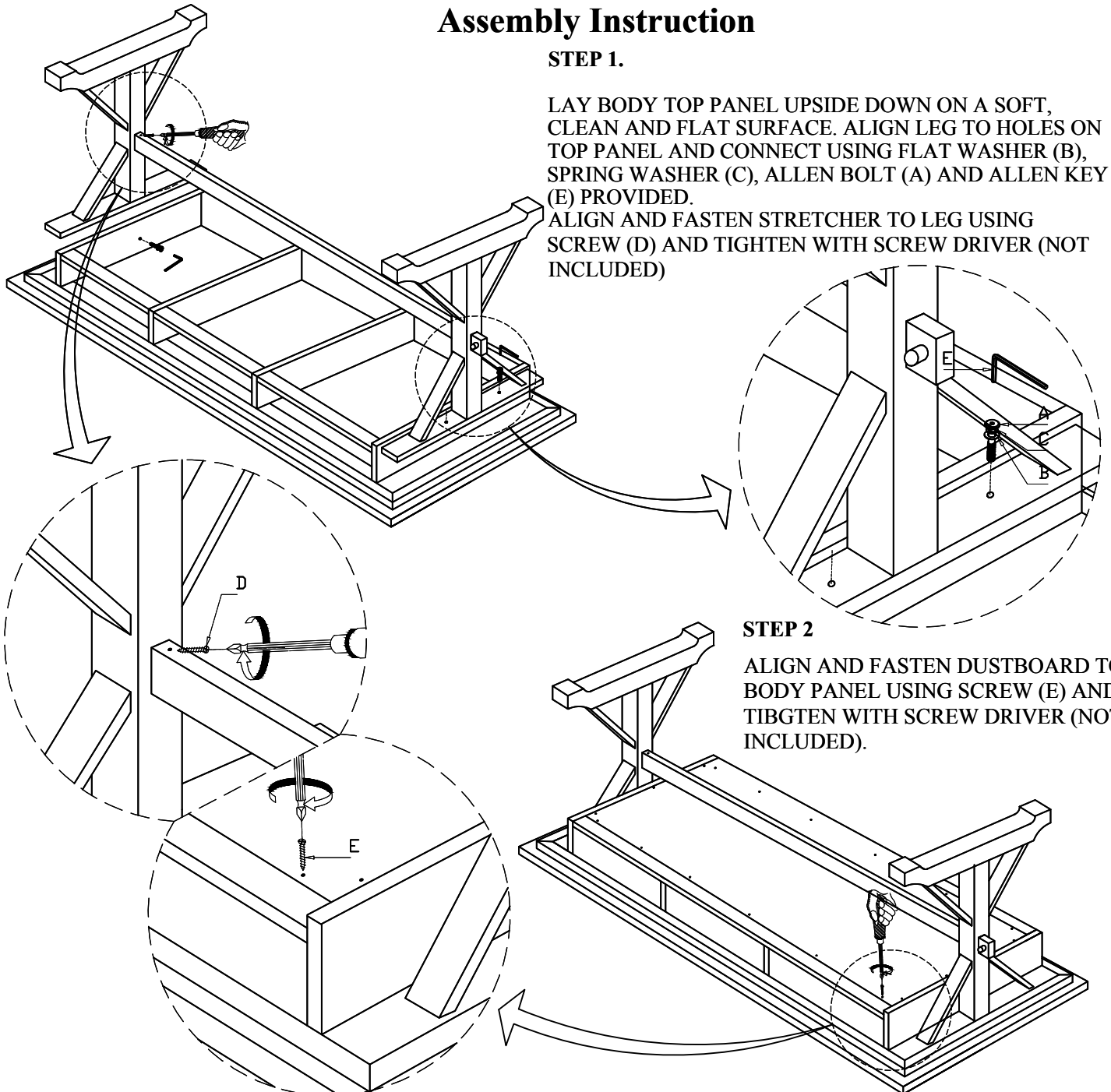

STEP 2

ALIGN AND FASTEN DUSTBOARD TO BODY PANEL USING SCREW (E) AND TIGHTEN WITH SCREW DRIVER (NOT INCLUDED).