



BEST CHOICE
PRODUCTS



INSTRUCTION MANUAL

Pop-Up Christmas
Snowman



**BEST CHOICE
PRODUCTS**

As shoppers, we're always trying to find the perfect balance between quality & value. At BCP, we believe we've achieved that. Our diverse catalog of everyday essentials is tailored especially to our customers & guaranteed to hit that sweet spot of high quality & low price.

— Always. —

! NOTICE

Please retain these instructions for future reference.

- This product is intended for outdoor use and should be assembled outdoors only.
- This item is not intended for permanent installation or use.
- Unplug item when not in use or if left unattended.
- Ensure that your voltage is consistent with specifications.
- If any parts are missing, broken, damaged, or worn, stop using this product until repairs are made and/or factory replacement parts are installed.
- Do not use this item in a way inconsistent with the manufacturer's instructions as this could void the product warranty.



1 PERSON
ASSEMBLY



UP TO 25 MIN.
ASSEMBLY

! WARNING

- Do not plug into a wall outlet until item is fully assembled and lights are properly connected.
- Do not use in extreme weather conditions.
- Keep item away from all heat sources (fireplace, stove, heater, etc.).
- Please use the provided stakes to properly secure the figure.
- Do not secure wiring with staples, nails, or sharp hooks.
- Do not hang ornaments or other objects from the cord.
- Unplug item before removing or changing bulbs.
- Replace burned-out bulbs immediately. Make sure to purchase bulbs of the same rated voltage and wattage.

HARDWARE

1

STAKE



6 PCS

2

LIGHT HOOK



2 PCS

PARTS

A

SNOWMAN BODY



1 PC

B

BASE STAND



1 PC

C

TOP POLE

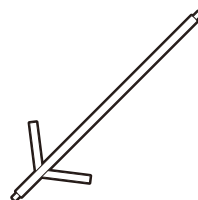

1 PC

PARTS

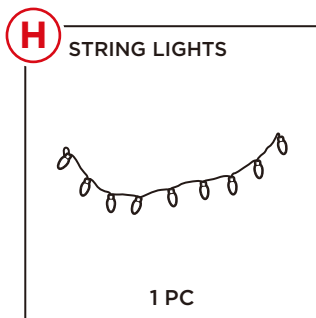
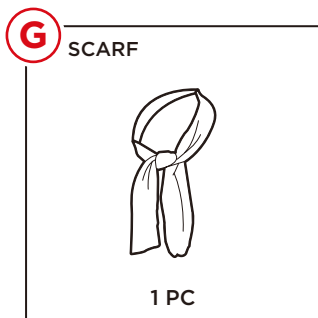
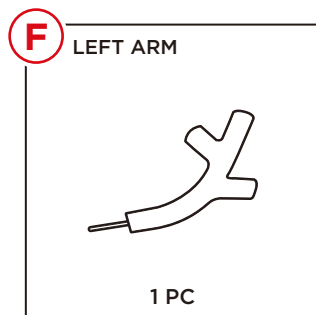
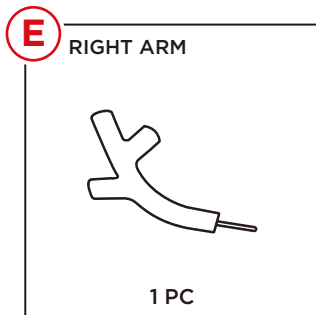
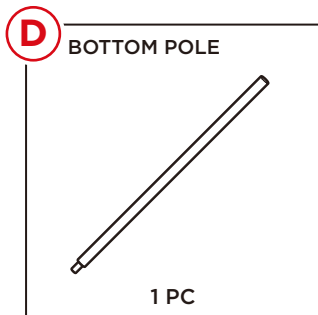

PRODUCT ASSEMBLY

1

Locate the part A snowman body and turn it upside down with the snowman's hat on the ground.

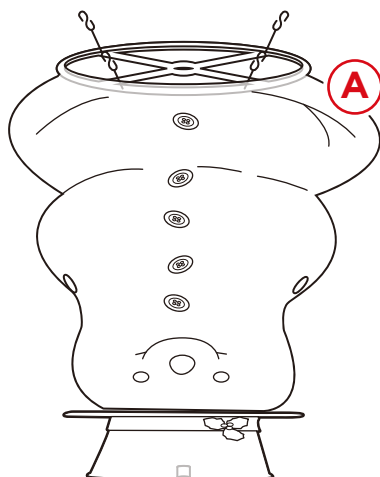

PRODUCT ASSEMBLY

2

Insert the part C top pole through the bottom opening of the part A snowman body. Insert the top of the pole into the opening in the snowman's hat, then thread the lower end of the pole through the metal ring in the center of the snowman body.

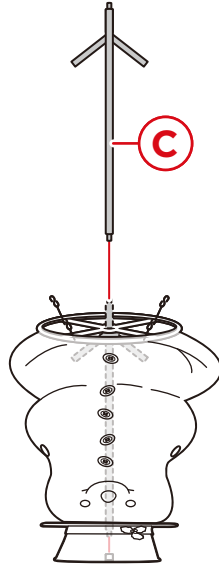

3

Flip the part A snowman body upright and insert the part D bottom pole into the part C top pole through the metal ring in the snowman's bottom.

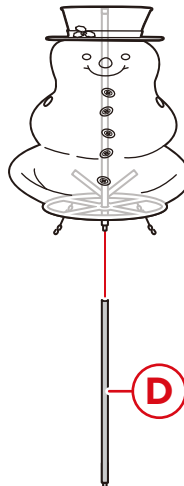

PRODUCT ASSEMBLY

4

Insert the part D bottom pole into the part B base stand.

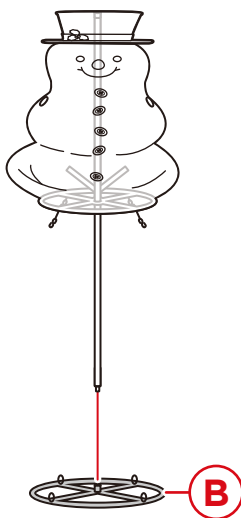

5

Locate the openings on either side of the part A snowman body and insert the part E & F arms. Connect the arms to the branches of the part C top pole.

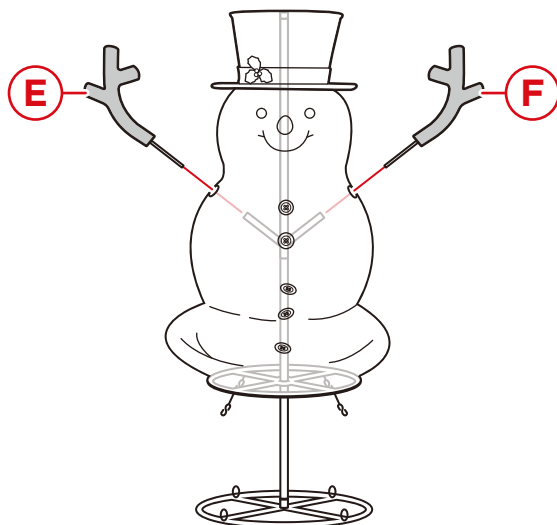

PRODUCT ASSEMBLY

6

Use both hands to grip the hooks at the bottom of the part A snowman body and pull downward to the part B base stand, secure the hooks.

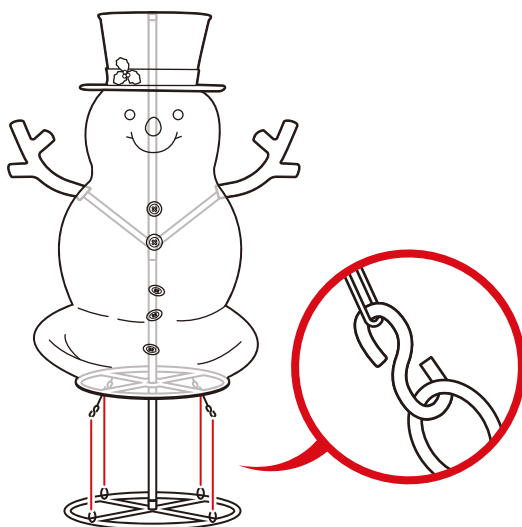

7

Wrap the part G scarf around the snowman's neck.

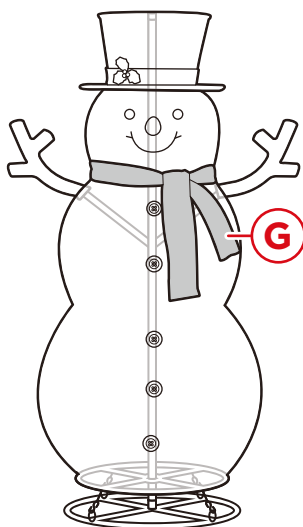

PRODUCT ASSEMBLY

8

Attach the part 2 light hooks to the part H string lights and drape the lights over the snowman as desired.

Locate the white plug on the part A snowman and connect it to the black plug on the part H string lights.

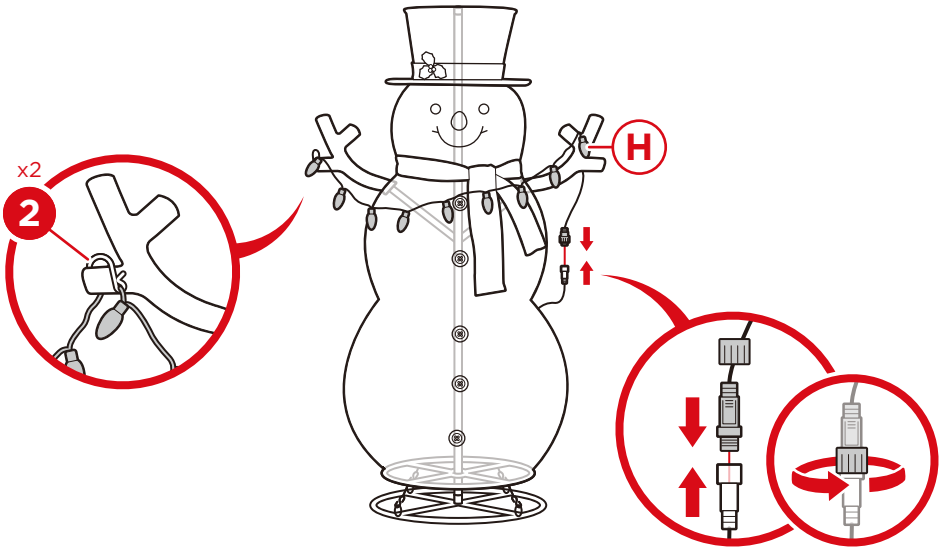

9

Secure the snowman figure to the ground with six part 1 stakes. Plug into a wall outlet to turn on the lights.

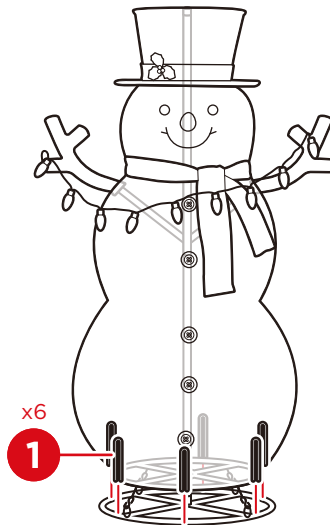

LIGHT SPECIFICATIONS

BULB TYPE(S)	BULB SIZE	WATTAGE	VOLTAGE	WHAT IF 1 BULB BREAKS
FAIRY	5MM	0.04W	3V	The entire string of lights up to that point will shut off



**BEST CHOICE
PRODUCTS**

Check out more great products:
[bestchoiceproducts.com](https://www.bestchoiceproducts.com)

Earn points while you shop. Join today!

bestchoiceproducts
rewards

Join | Earn | Redeem

Give your friends 15% off their first order! For each successful referral you'll receive 100 points.

bestchoiceproducts.com



HELP CENTER



Question about your product? We're here to help. Visit us at:

help.bestchoiceproducts.com



Chat Support



Product Inquiry



Orders FAQ



Product Assembly



Returns & Refunds

PRODUCT WARRANTY INFORMATION

All items can be returned for any reason within 60 days of the receipt and will receive a full refund as long as the item is returned in its original product packaging and all accessories from its original shipment are included. All returned items will receive a full refund back to the original payment method. All returned items will not be charged a re-stocking fee.

All returned items require an RA (Return Authorization) number, which can only be provided by a Best Choice Products Customer Service Representative when the return request is submitted. Items received without an RA may not be accepted or may increase your return processing time. Once an item has been received by Best Choice Products, refunds or replacements will be processed within 5 business days.

All returns must be shipped back to the Best Choice Products Return Center at the customer's expense. If the reason for return is a result of an error by Best Choice Products then Best Choice Products will provide a pre-paid shipping label via email. Boxes for return shipping will not be provided by Best Choice Products, and is the customer's responsibility to either use the original shipping boxes or purchase new boxes.

Pictures may be required for some returns to ensure an item is not damaged prior to its return. Items returned are not considered undamaged until they are received by Best Choice Products and verified as such. All damages to items are the customer's responsibility until the item has been received by and acknowledge by Best Choice Products as undamaged.



WARNING

Manufacturer and seller expressly disclaim any and all liability for personal injury, property damage or loss, whether direct, indirect, or incidental, resulting from the incorrect attachment, improper use, inadequate maintenance, unapproved modification, or neglect of this product.