









# HEKMAN<sup>®</sup>

**X** A HOWARD MILLER COMPANY

## 79400P / 79420P PEDS & MODESTY PANEL 79400T / 79420T TOP PANEL

HARDWARE LIST					
A	B	C	D	E	F
ALLEN BOLT $\frac{5}{16}$ " x 2" (4 Pcs)	ALLEN BOLT $\frac{5}{16}$ " x 6" (2 Pcs)	FLAT W. M8 (6 Pcs)	LOCK W. M8 (6 Pcs)	ALLEN KEY L5 (FOR BOLT $\frac{5}{16}$ " 1 Pc)	COVER CAPS (4 Pcs)
					

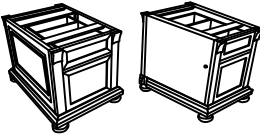
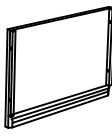

PART INSIDE			
1	2	3	4
TOP ASSEMBLY (1 Pc)	PEDESTALS (2 Pcs)	MODESTY PANEL (1 Pc)	BUN FEET (8 Pcs)
			

### Assembly Instruction

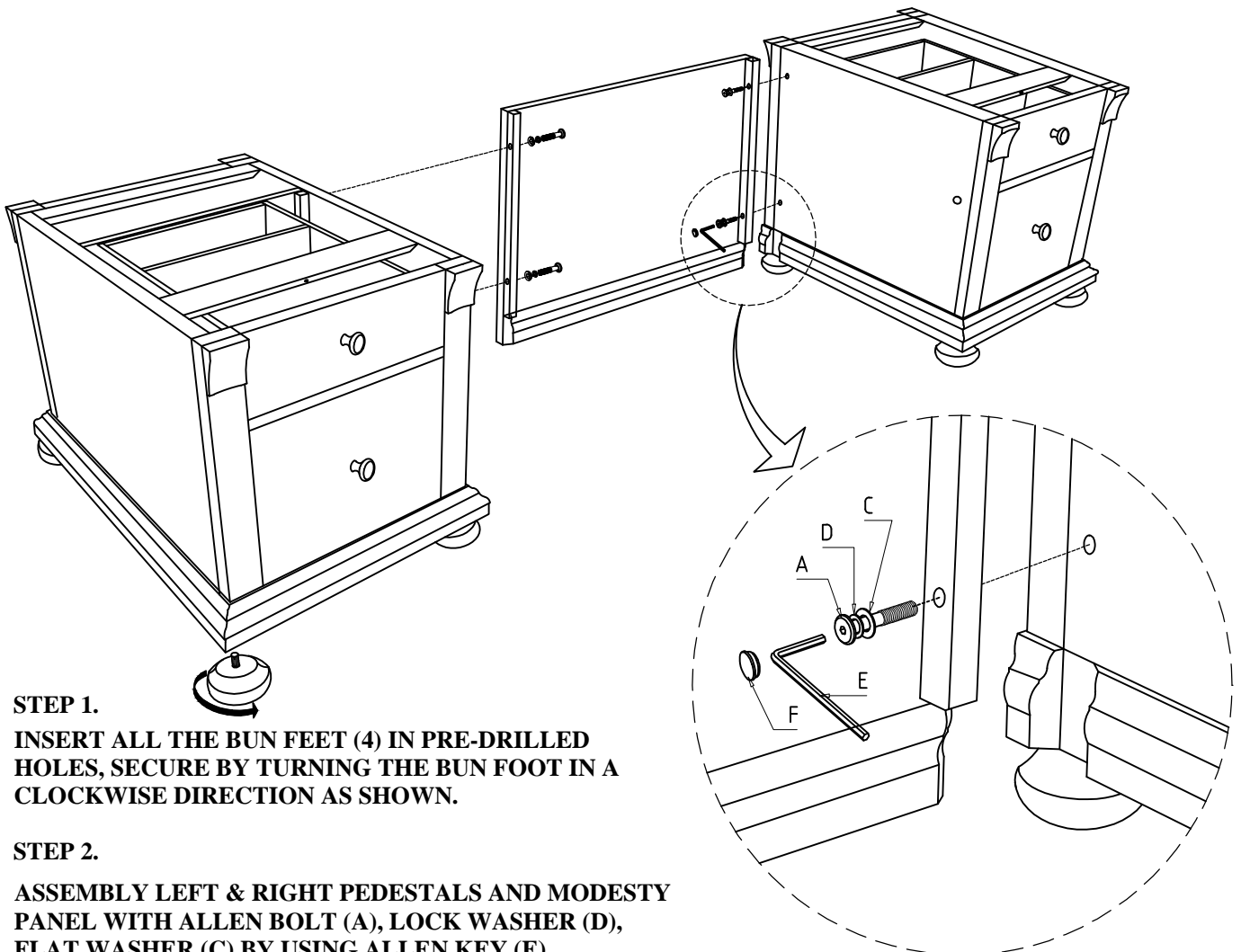

**STEP 1.**  
INSERT ALL THE BUN FEET (4) IN PRE-DRILLED HOLES, SECURE BY TURNING THE BUN FOOT IN A CLOCKWISE DIRECTION AS SHOWN.

**STEP 2.**  
ASSEMBLY LEFT & RIGHT PEDESTALS AND MODESTY PANEL WITH ALLEN BOLT (A), LOCK WASHER (D), FLAT WASHER (C) BY USING ALLEN KEY (E). COVER THE BOLTS WITH COVER CAPS (F).

**STEP 3.**

PLACE THE TOP ASSEMBLY ON THE PEDESTALS AS SHOWN IN THE SIDE VIEW THE TOP ASSEMBLY IS SET A LITTLE FORWARD ON THE PEDESTALS THAN PUSHED BACK TO LOCK FRENCH CLEATS. OPEN THE UPPER DRAWERS IN THE PEDESTALS. SCREW THE TOP PANEL ASSEMBLY AND PEDESTALS WITH ALLEN BOLT (B), LOCK WASHER (D), FLAT WASHER (C) USING ALLEN KEY (E). CLOSE UPPER DRAWERS.

