

# ASSEMBLY INSTRUCTION

## PART LIST:

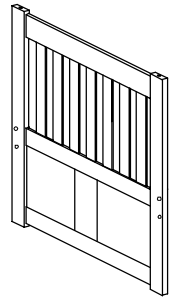

① Left facing board 1PC

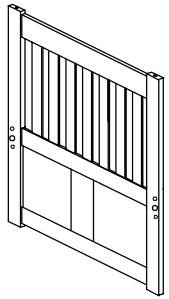

② right facing board. 1PC

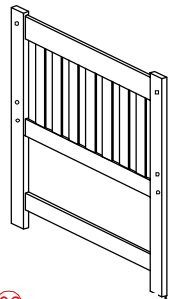

③ Left facing board. 1PC

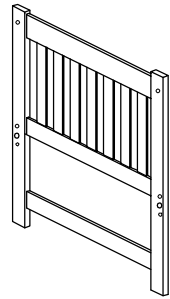

④ facing Board. 1PC

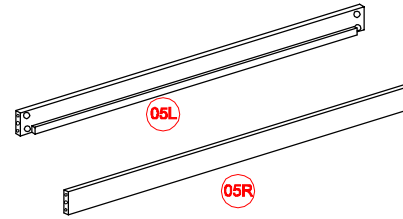

⑤ Rail 2PCS

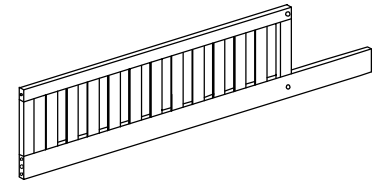

⑥ Front Guard Rail 1PC

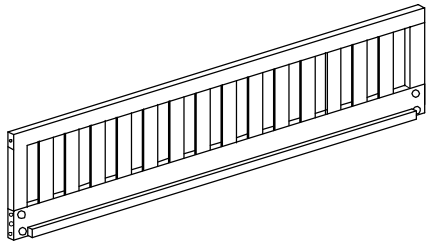

⑦ Back Guard Rail 1PC



⑧ Left Ladder post 1PC



⑨ Right ladder post 1PC



⑩ Ladder Step 4PCS

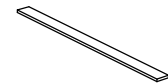

⑪ Slat 26 PCS

## HARDWARE LIST

A		Bolt	1/4"X3 3/16"	16PCS	F		Wrench		1PC
B		Bolt	1/4"X3 1/8"	3PCS	G		Pin	3 1/2"	4PCS
C		Bolt	1/4"X2 3/8"	8PCS	H		Wood dowel	1 3/4"	16PCS
D		Bolt	1/4"X2"	5PCS	I		Washer		16PCS
E		Screw	5/32"X1 3/8"	52PCS					

# ASSEMBLY INSTRUCTION

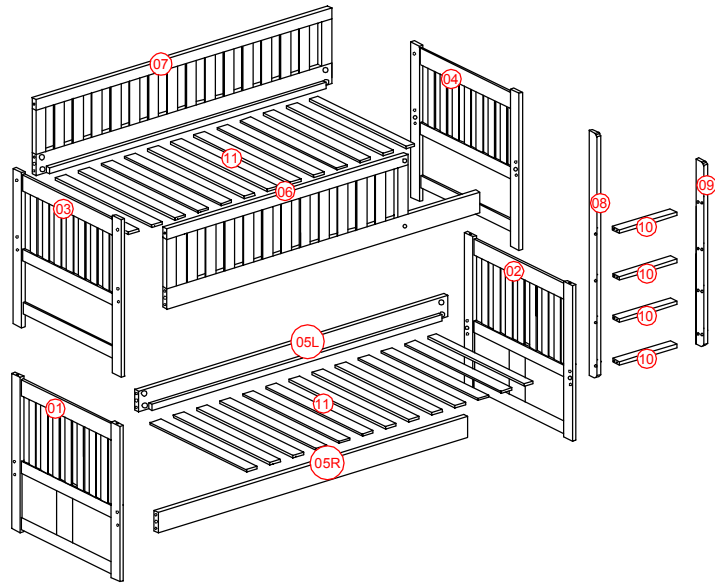

## STEP 1

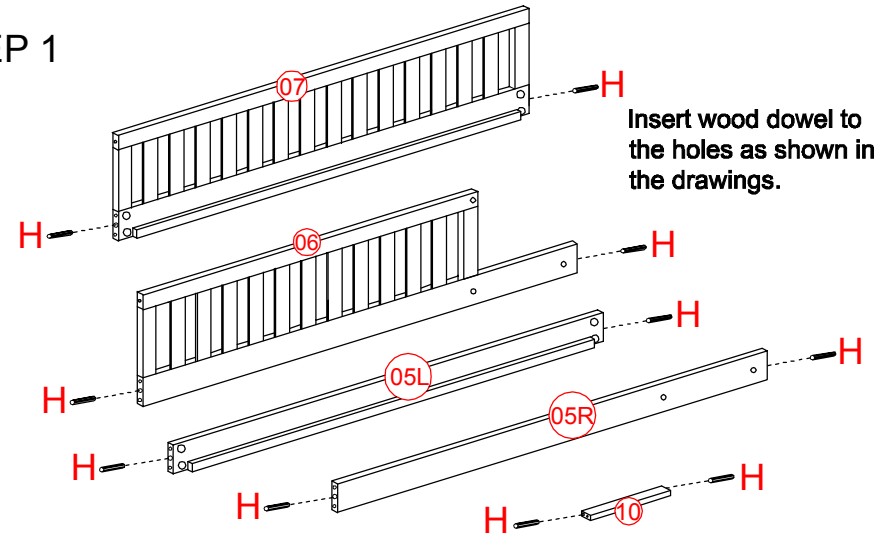

## STEP 2 Lower Bed

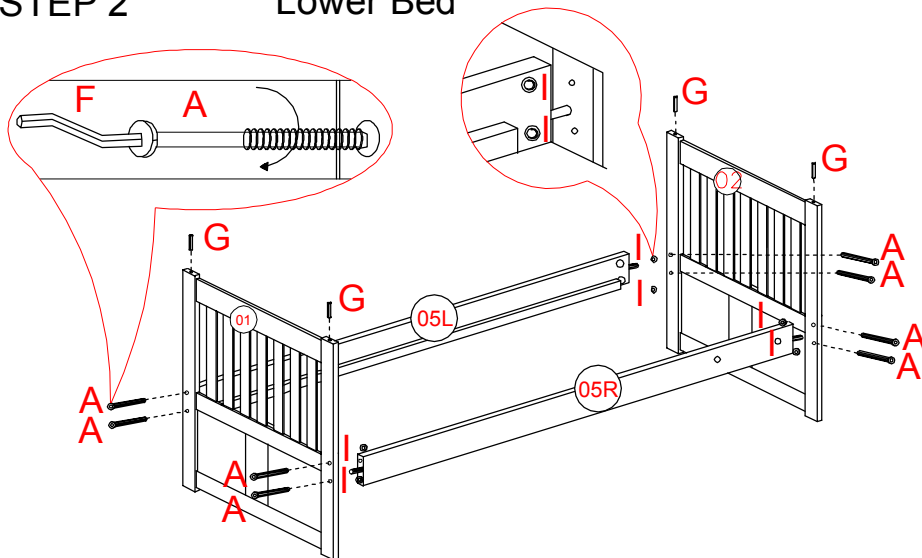

## STEP 3 Upper Bed

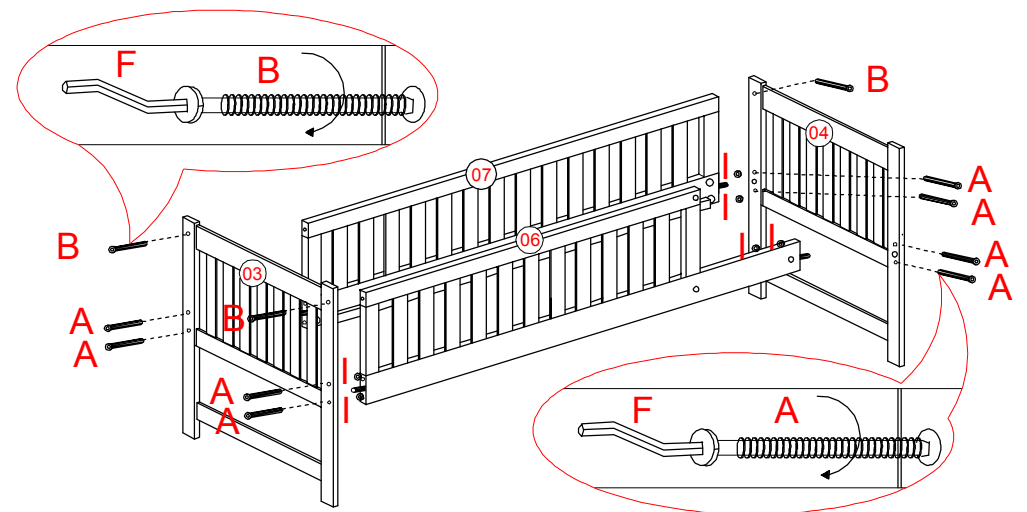

# ASSEMBLY INSTRUCTION

STEP 4 Ladder

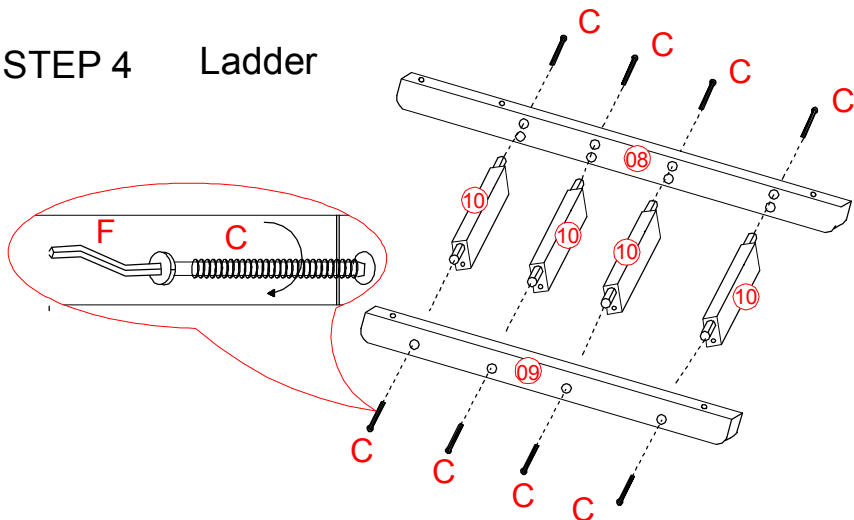

STEP 5

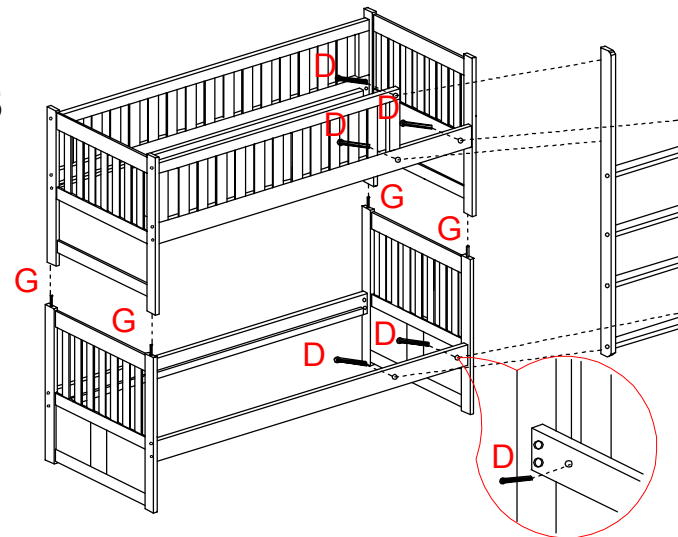

STEP 6

COMPLETED

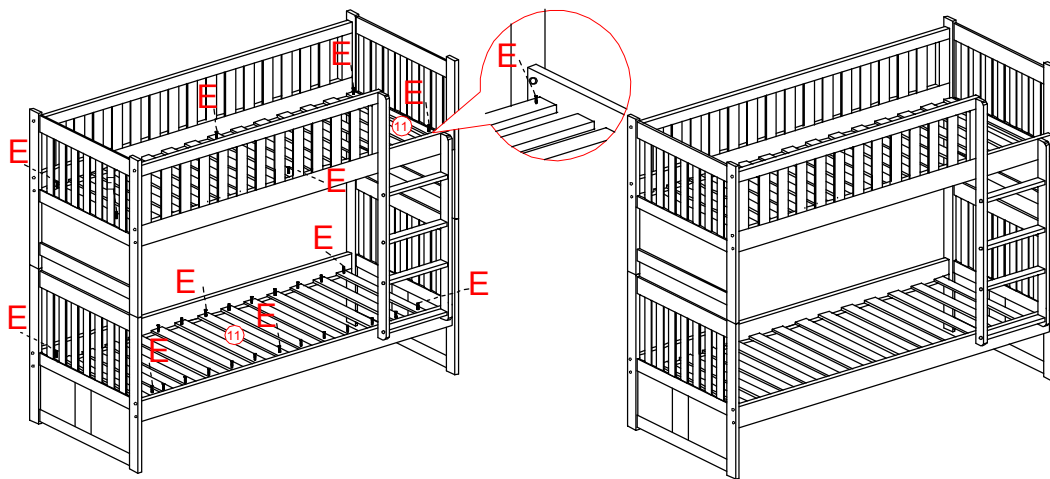

## WARNING

**TO HELP PREVENT SERIOUS OR FATAL INJURIES FROM ENTRAPMENT OR FALLS**

1. NEVER ALLOW CHILDREN UNDER 6 YEARS ON UPPER BUNK
2. USE ONLY MATTRESS WHICH IS 37" 1/2-38" 1/2 WIDTH AND 74"-75" LENGTH ON UPPER BUNK(TWIN SIZE)
3. ENSURE THICKNESS OF MATTRESS DOES NOT EXCEED 6" AND MATTRESS SURFACE IS AT LEAST 5 INCHES BELOW UPPER OF GUARDRAILS.
4. USE GUARDRAILS ON BOTH SIDE OF UPPER BUNK
5. PROHIBIT HORSE PLAY ON,OR UNDER BED(S)
6. PROHIBIT MORE THAN ONE PERSON ON BUNK
7. USE LADDER FOR ENTERING AND LEAVING UPPER BUNK
8. IF THE BUNK BED WILL BE PLACED NEXT TO A WALL, THE GUARDRAIL THAT RUNS THE FULL LENGTH OF THE BED SHOULD BE PLACED AGAINST THE WALL TO PREVENT ENTRAPMENT BETWEEN THE BED AND WALL
9. DO NOT EXCEED 165 LBS(75Kgs)ON UPPER BUNK

**STRANGULATION HAZARD**

10. NEVER ATTACH OR HANG ITEMS TO ANY PART OF THE BUNK BED THAT ARE NOT DESIGNED FOR USE WITH THE BED, FOR EXAMPLE, BUT NOT LIMITED TO BOOKS,BELTS,AND JUMP ROPES

**CERTIFID:**

THIS BUNK BED CONFORMS TO ALL APPLICABLE CONSUMER PRODUCTS SAFETY STANDARDS 16 CFR PARTS 1213,1500,1513AND ASTM F-1427

# ASSEMBLY INSTRUCTION

## PART LIST:

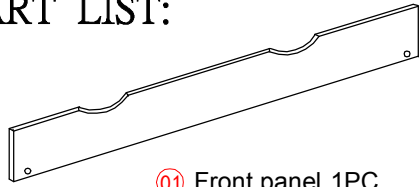

① Front panel 1PC

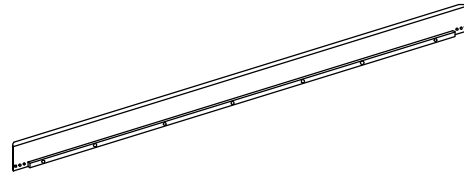

② Back Rail 1PC

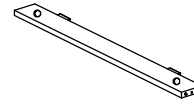

③ Stretcher 2PCS



④ Slat 12 PCS

### STEP 1

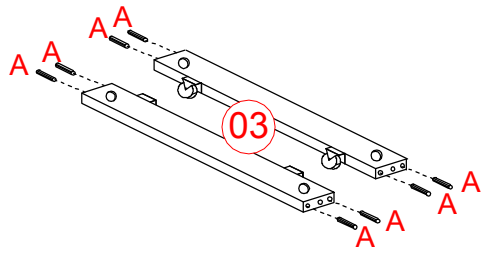

### STEP 2

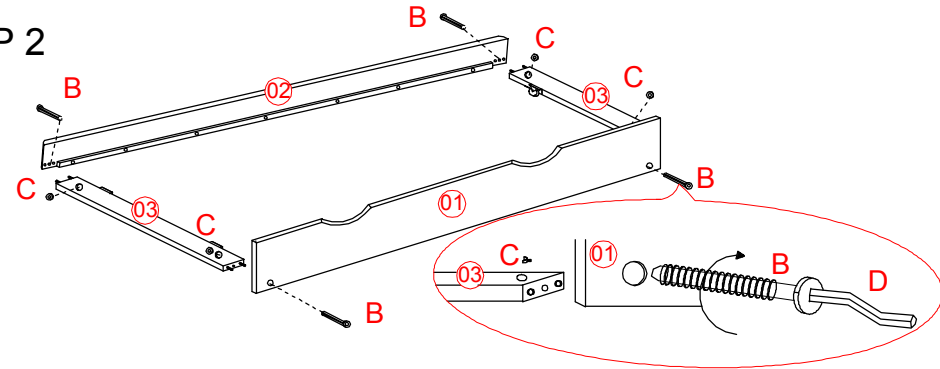

### STEP 3

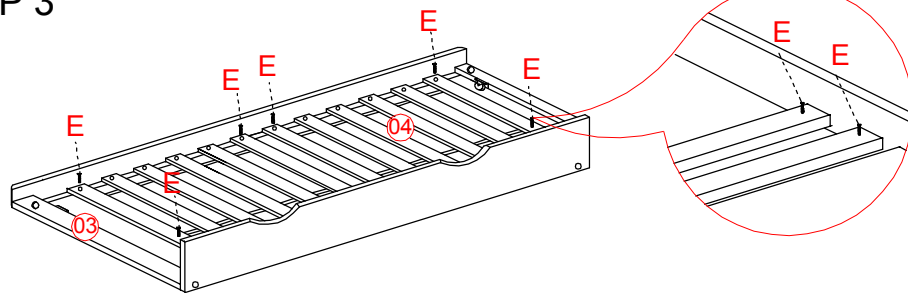

COMPLETED!

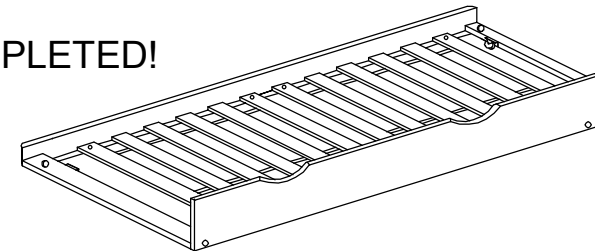

## HARDWARE LIST

A		Wood dowel	1 3/16"	8PCS	D		Wrench		1PC
B		Bolt	1/4"X2 3/4"	4PCS	E		Screw	5/32"X1 3/8"	24PCS
C		Washer		4PCS					