







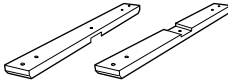
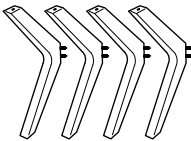
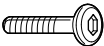

ASSEMBLY INSTRUCTION

ROUND END TABLE

A Table Top  1 pc	B Pedestal  1 pc	C Cross Bar  2 pcs	D Table Leg  4 pcs
E JCBC Bolt M6 x 30mm  5 pcs	F Spring Washer M6  5 pcs	G Allen Key M4 x 110mm  1 pc	H Hex Comb M8  8 pcs
I Spring Washer M8  8 pcs	J Flat Washer M8  8 pcs	K Spanner 12.8mm  1 pc	



This page lists all the contents included in the box. Please take the time to identify the hardware as well as the individual components to this product. As you unpack and prepare for assembly, place the contents on a carpeted or padded area to protect them from damage.

- 1** Uninstall Cross Bar (C) from Table Top (A) as shown below. Use Allen Key (G) to unscrew the JCBC Bolt and Spring Washer from both of the Cross Bar. Retain hardware for assembling in Step 4.

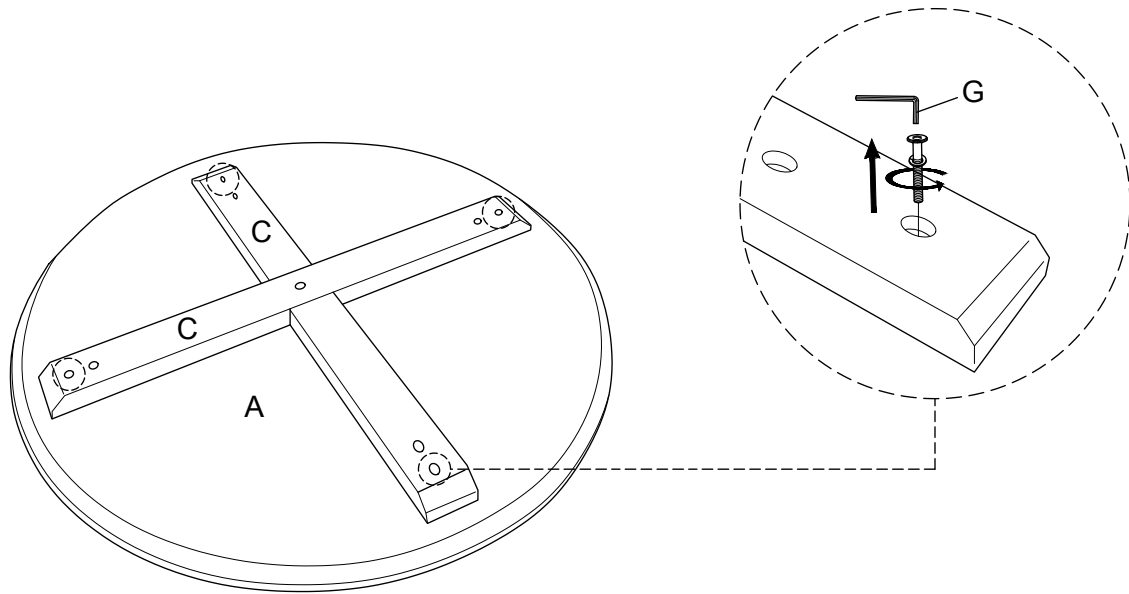

- 2** Install Table Leg (D) with Pedestal (B) by using Flat Washer (J), Spring Washer (I), and Hex Comb (H). Use Spanner (K) to tighten the Hex Comb (H) but make sure not to over tighten.

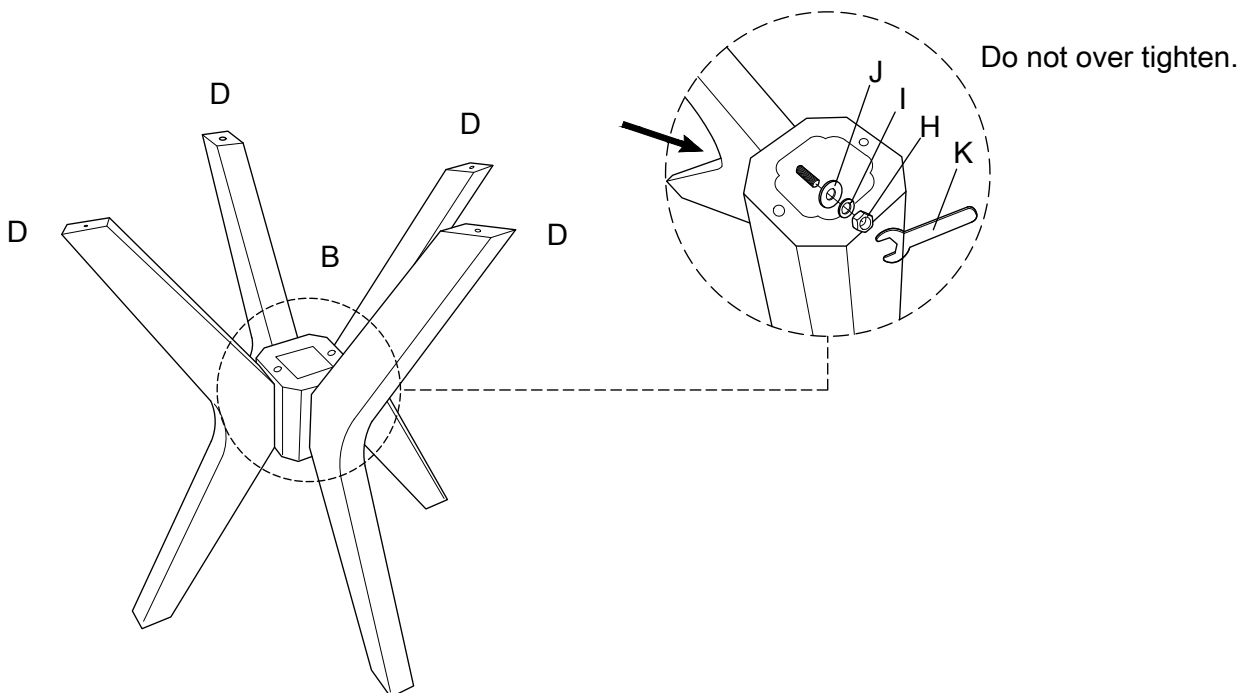

3 Install both Cross Bar (C) to the Table Leg (D). Use Spring Washer (F) and JCBC Bolt (E) and tighten the assembly by Allen Key (G).

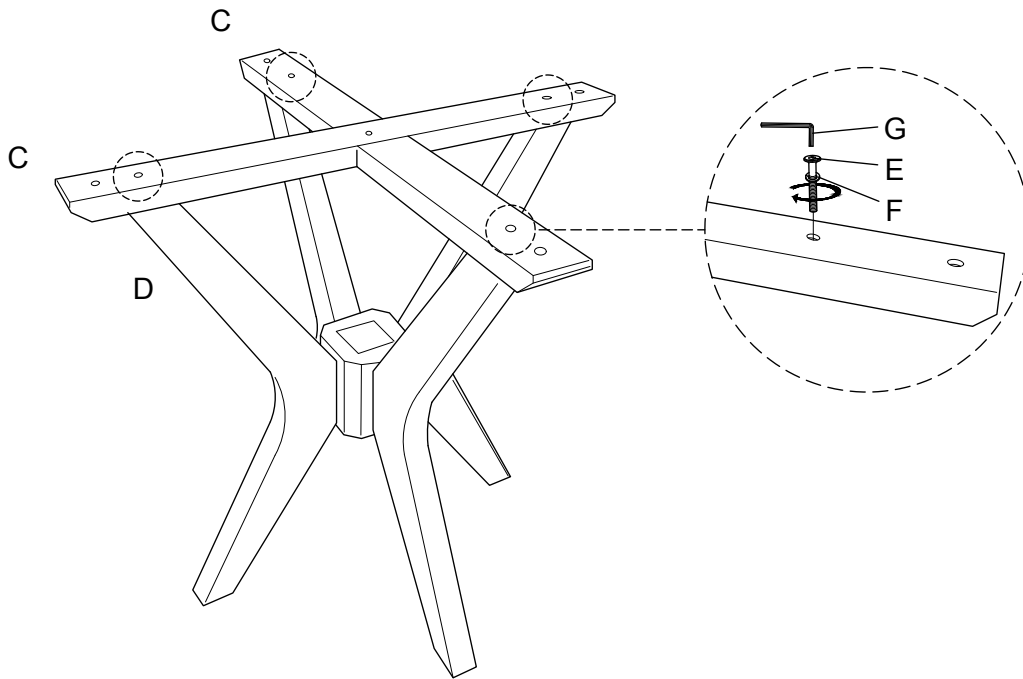

4 Install the table by using the remain hardware from Step 1. Then continue assembling by using the prepared hardware Spring Washer (F) and JCBC Bolt (E) and tighten all section using Allen Key (G).

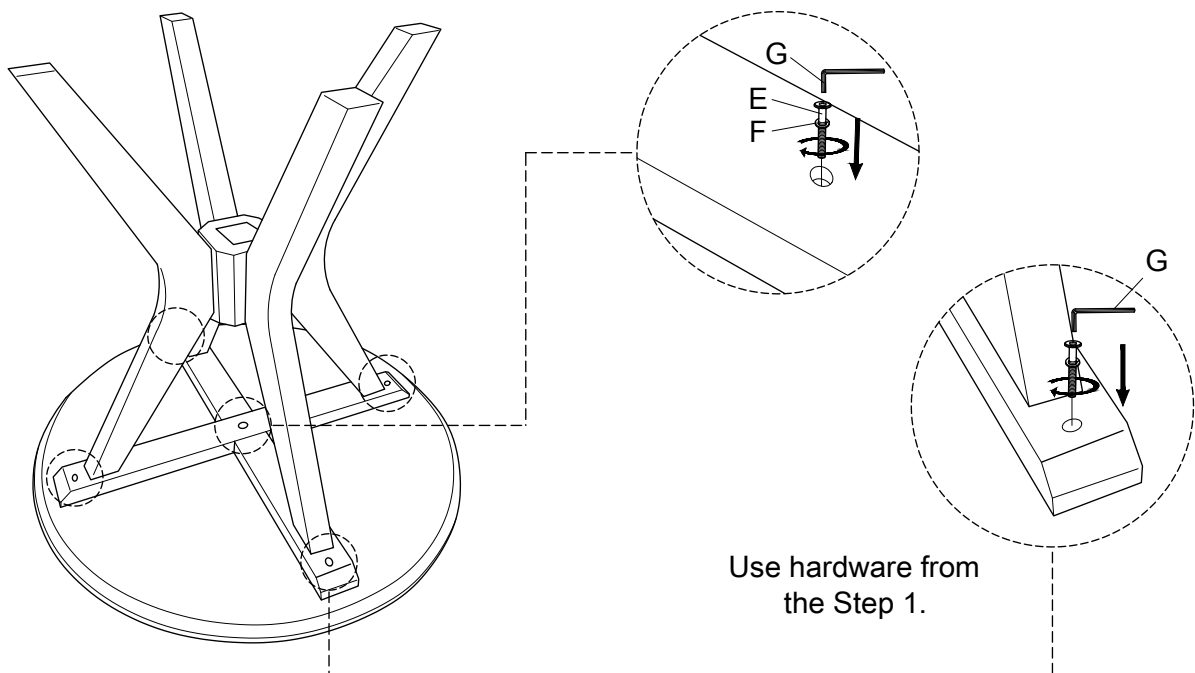

- 5** Flip over the previous assembly from Step 4 and place the cover of Pedestal (B) as shown below. Then, adjust the adjustable leg to balance the table.

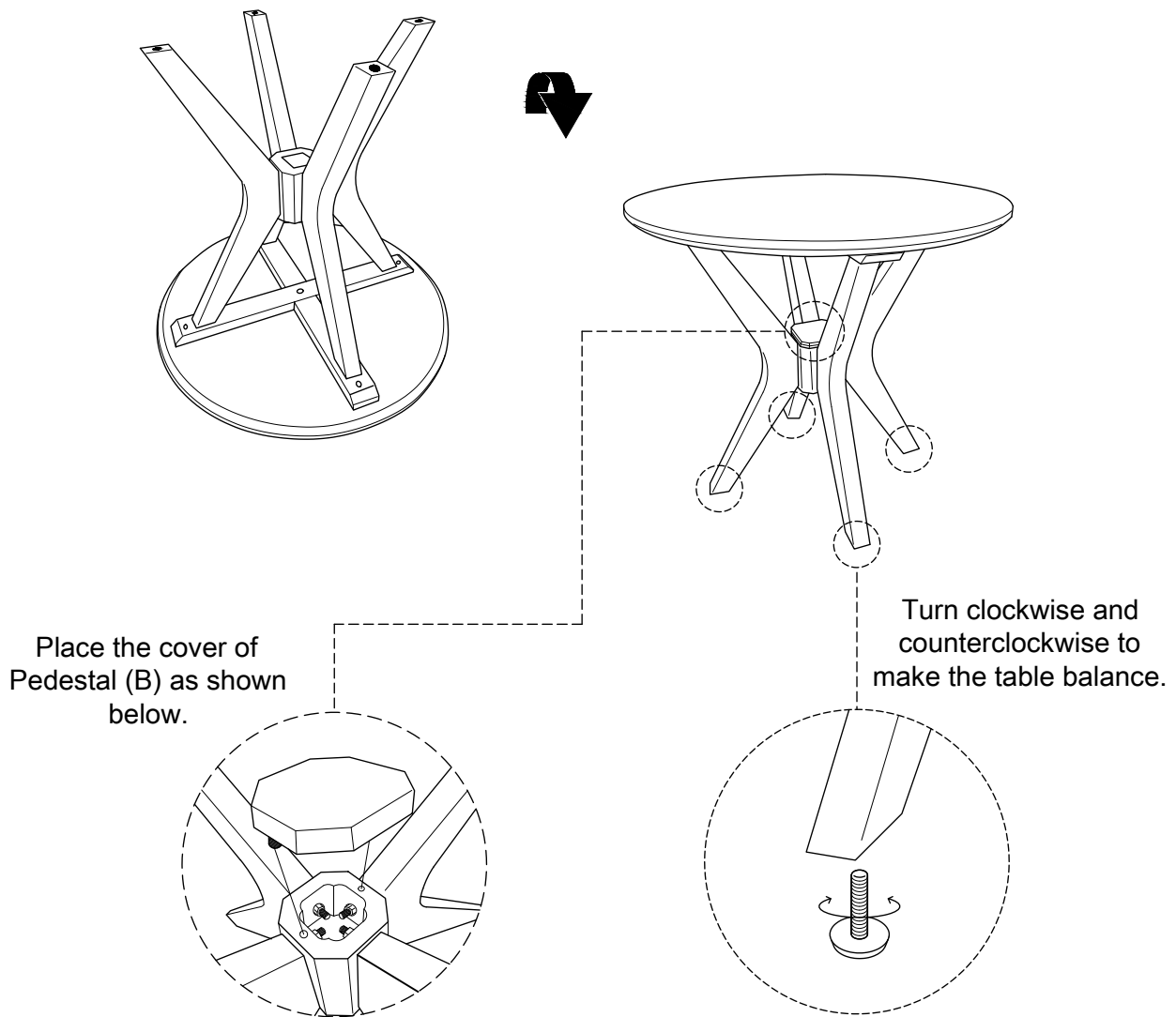









Stand the table up on even surface and check that it is balanced. If there is a slight wobble, apply downward pressure in the corner where a leg is uneven. Keeping pressure in that corner, tighten all bolts. If balanced, apply downward pressure evenly in the center and tighten all bolts. Do not over-tighten beyond hole depth.

Cleaning & Care

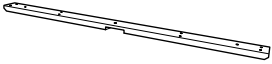
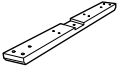
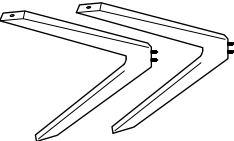
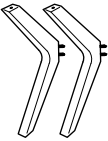
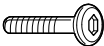
Treat surface with care. Surface is resistant to scratches but is not scratch resistant. Clean surfaces with a dry or damp soft cloth. Do not use abrasive cleaners. Hardware may loosen over time. Periodically check that all connections are tight.

ASSEMBLY INSTRUCTION

OVAL COFFEE TABLE

A Table Top  1 pc	B Pedestal  1 pc	C Cross Bar - Long  1 pc	D Cross Bar - Short  1 pc
E Table Leg - Big  2 pcs	F Table Leg - Small  2 pcs	G JCBC Bolt M6 x 30mm  7 pcs	H Spring Washer M6  7 pcs
I Allen Key M4 x 110mm  1 pc	J Hex Comb M8  8 pcs	K Spring Washer M8  8 pcs	L Flat Washer M8  8 pcs
M Spanner 12.8mm  1 pc			

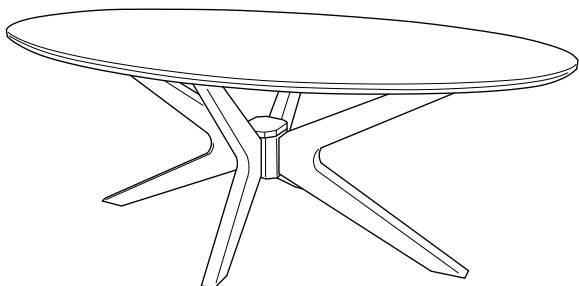

This page lists all the contents included in the box. Please take the time to identify the hardware as well as the individual components to this product. As you unpack and prepare for assembly, place the contents on a carpeted or padded area to protect them from damage.

- 1** Uninstall both Cross Bar - Short (D) and Cross Bar - Long (C) from Table Top (A) as shown below. Use Allen Key (I) to unscrew the JCBC Bolt and Spring Washer from both of the Cross Bar. Retain hardware for assembling in Step 6.

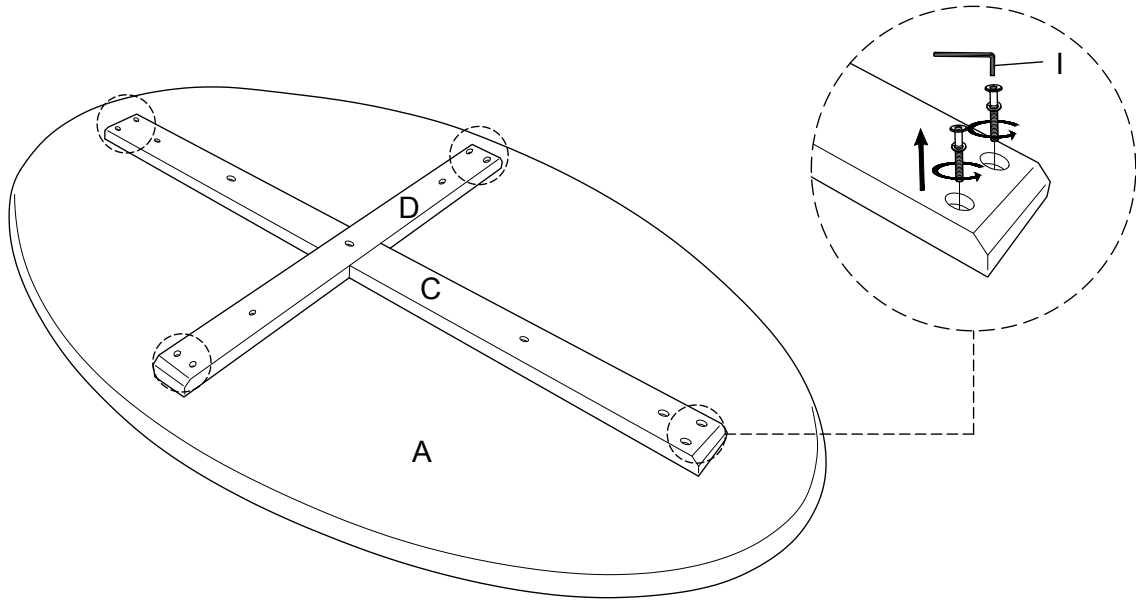

- 2** Install Table Leg - Big (E) with Pedestal (B) by using Flat Washer (L), Spring Washer (K), and Hex Comb (J). Use Spanner (M) to tighten the Hex Comb (J) but make sure not to over tighten.

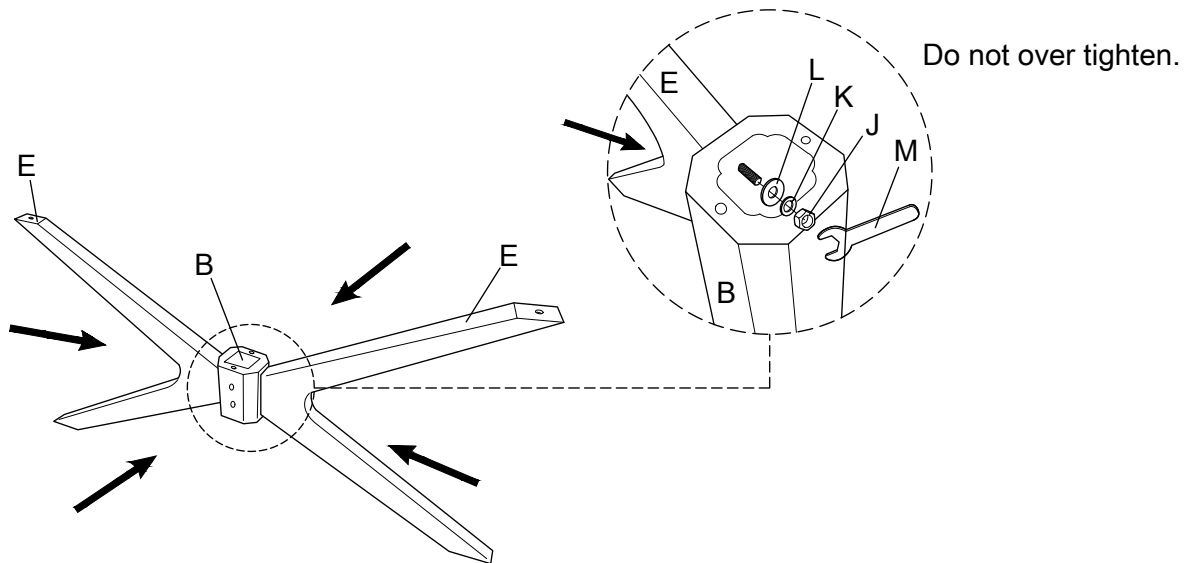

3 Then, install Table Leg - Small (F) with Pedestal (B) by using Flat Washer (L), Spring Washer (K), and Hex Comb (J). Use Spanner (M) to tighten the Hex Comb (J) but make sure not to over tighten.

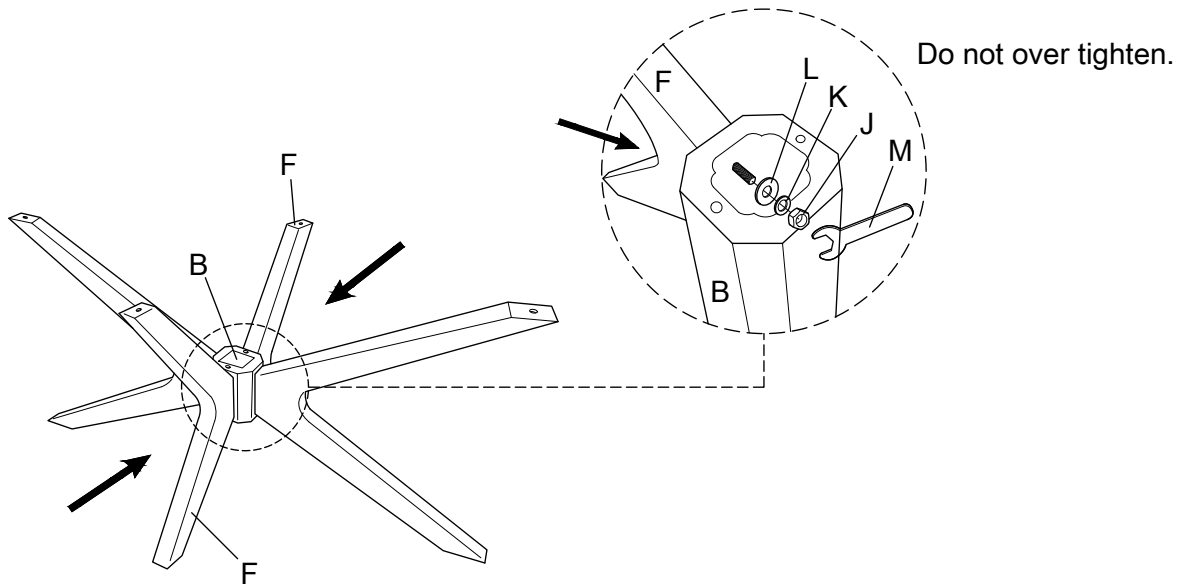

4 Install both Cross Bar - Short (D) and Cross Bar - Long (C) to the Table Leg - Big (E) and Table Leg - Small (F). Use Spring Washer (H) and JCBC Bolt (G) to tighten the assembly by Allen Key (I).

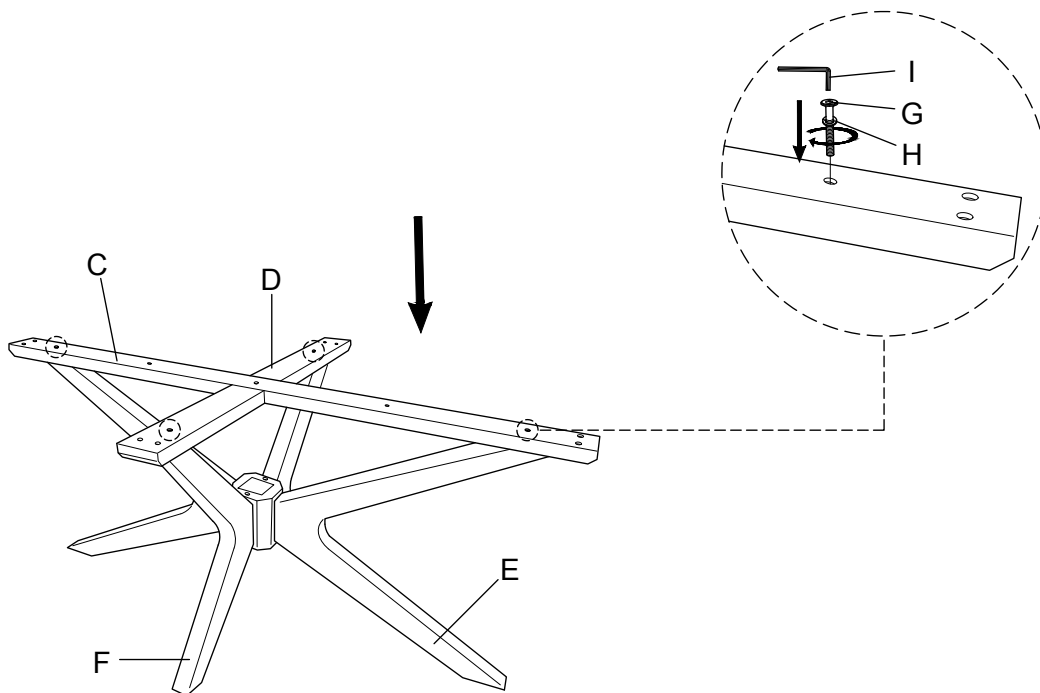

5 Flip over the previous assembly from Step 4 on bottom part of Table Top (A) as shown below. This step needs an assistance to flip the previous assembled from Step 4.

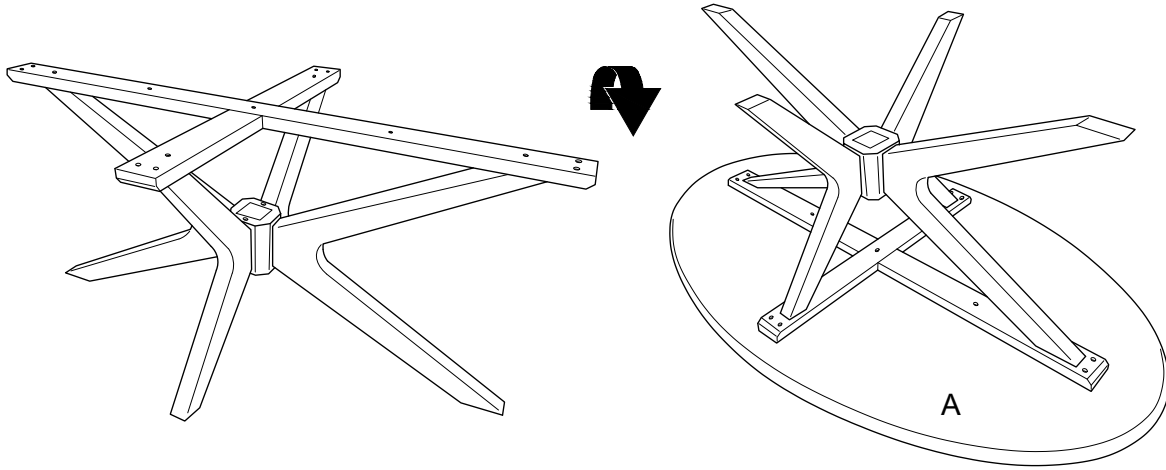

6 Install the table by using the remain hardware from Step 1. Then continue assembling by using the prepared hardware Spring Washer (H) and JCBC Bolt (G) and tighten all section using Allen Key (I).

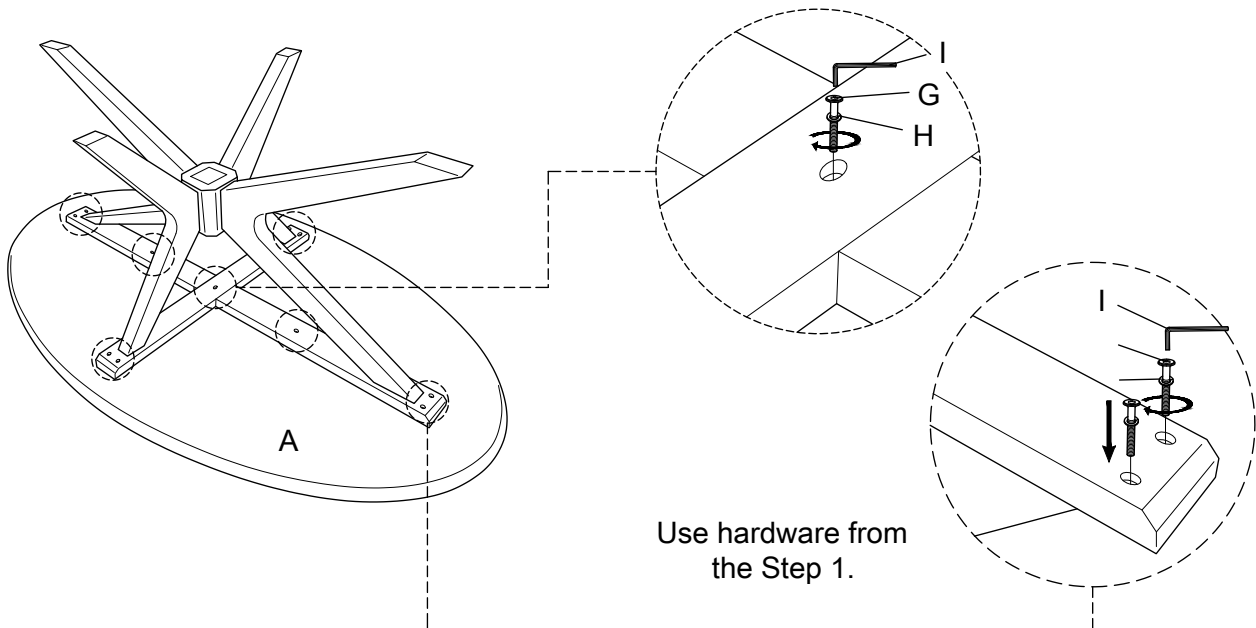

7 Flip over the previous assembly from Step 6 and place the cover of Pedestal (B) as shown below. Then, adjust the adjustable leg to balance the table.

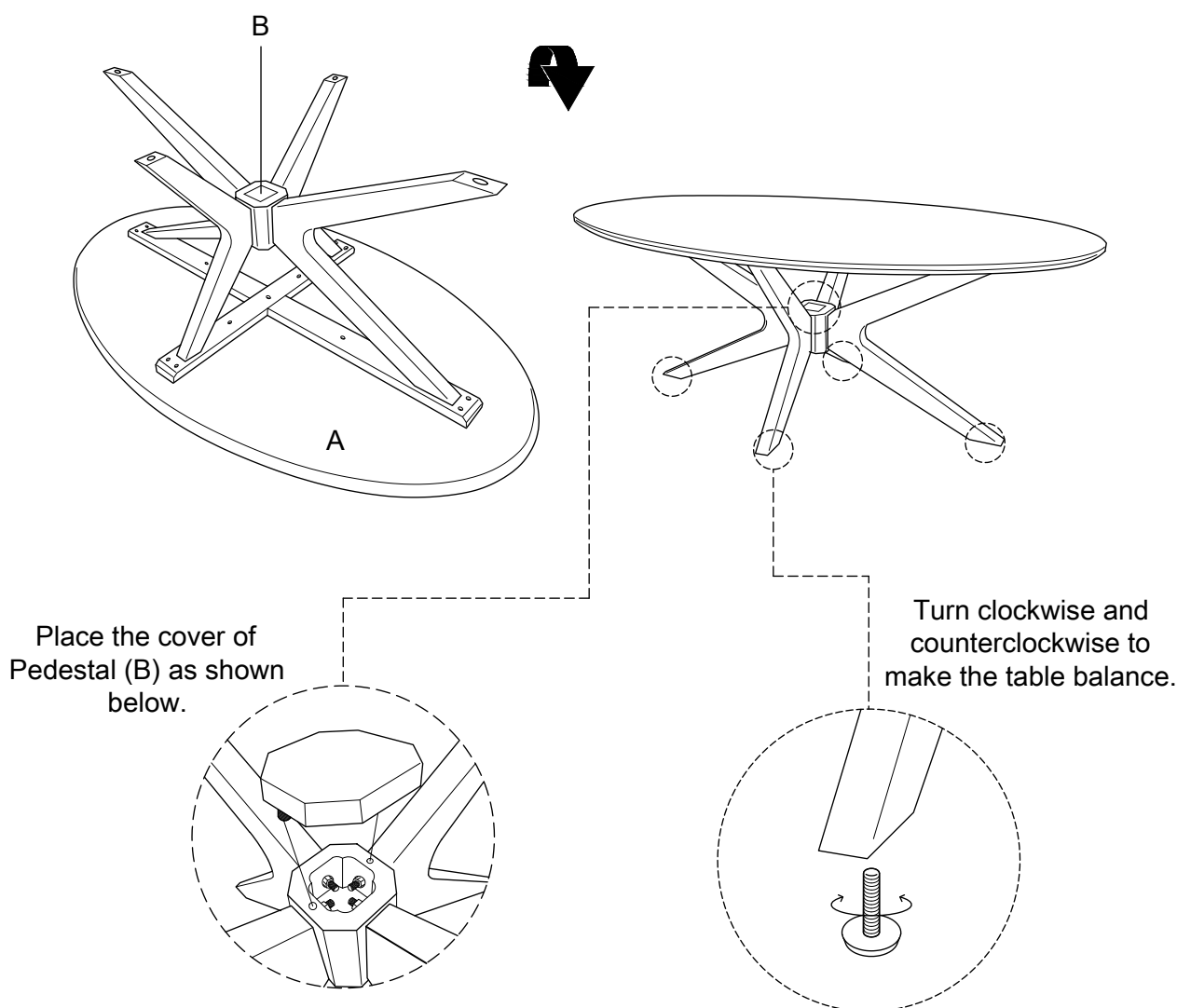

Stand the table up on even surface and check that it is balanced. If there is a slight wobble, apply downward pressure in the corner where a leg is uneven. Keeping pressure in that corner, tighten all bolts. If balanced, apply downward pressure evenly in the center and tighten all bolts. Do not over-tighten beyond hole depth.

Cleaning & Care

Treat surface with care. Surface is resistant to scratches but is not scratch resistant. Clean surfaces with a dry or damp soft cloth. Do not use abrasive cleaners. Hardware may loosen over time. Periodically check that all connections are tight.