

F24917E

CLOVERDALE



OBSTACLE FREE SAFETY ZONE - 28' 8" x 27' x 15' 6" (8.7m x 8.2m x 4.7m) area requires Protective Surfacing. See page 4.

MAXIMUM VERTICAL FALL HEIGHT - 6' 9" (2.06 m).

CAPACITY - 10 Users Maximum, Ages 3 to 10; Weight Limit 110 lbs. (50 kg) per child.

RESIDENTIAL HOME USE ONLY. Not intended for public areas such as multi-unit residences, schools, churches, nurseries, day cares or parks.

Warning. Only for domestic use.

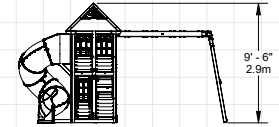
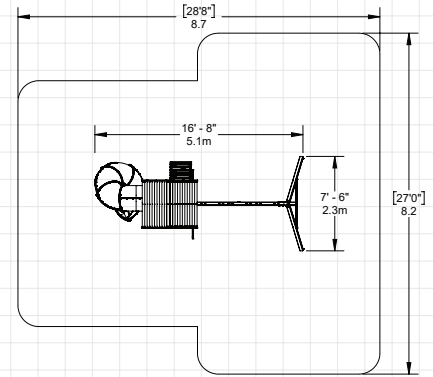

INSTALLATION AND OPERATING INSTRUCTIONS

FOR 24/7 ONLINE PARTS REPLACEMENT

parts.kidkraft.com

KidKraft, Inc.
4630 Olin Road
Dallas, Texas 75244
USA

customerservice@kidkraft.com

1.800.933.0771
972.385.0100

parts.kidkraft.eu

KidKraft Netherlands BV
Olympisch Stadion 8
1076 DE Amsterdam
The Netherlands

europcustomerservice@kidkraft.com

+31 20 305 8620
M-F from 09:00 to 17:30 (GMT+1)

9404917E

Rev 12/19/2023

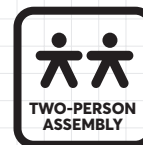

⚠️ WARNING

To reduce the risk of serious injury or death, please read and follow these instructions. Keep and refer to instructions as needed and pass along to any future owners of this item.

Congratulations on purchasing a KidKraft product!

**Our items are made of high-quality,
durable Cunninghamia Lanceolata wood
from the cypress family.**

**Lumber from these trees are known for
their light weight and excellent strength.
The porosity of this wood allows the
moisture to absorb and evaporate in the
fibers, resisting rot and bugs.**

**Engineered for great play, our products
also go through extensive testing for safety.**

**Plus, our team has developed a series of
proprietary methods for a simpler, more
organized assembly. Less build time and
more play time is our motto!**

**However, during assembly if you have any
questions or concerns, please reach out.
Our Customer Service can help with missing
parts, instructions or maintenance.**



Warnings and Safe Play Instructions



CONTINUOUS ADULT SUPERVISION REQUIRED. Most serious injuries and deaths on playground equipment have occurred while children were unsupervised! Our products are designed to meet mandatory and voluntary safety standards. Complying with all warnings and recommendations in these instructions will reduce the risk of serious or fatal injury to children using this play system. Go over the warnings and safe play instructions regularly with your children and make certain that they understand and follow them. Remember on-site adult supervision is required for children of all ages.



WARNING

SERIOUS HEAD INJURY HAZARD

Installation over concrete, asphalt, dirt, grass, carpet and other hard surface creates a risk of serious injury or death from falls to the ground. Install and maintain shock absorbing material under and around play-set as recommended on page 4 of these instructions.

COLLISION HAZARD

Place play-set on level ground at least 2m from any obstruction such as a garage or house, fences, poles, trees, sidewalks, walls, landscape timbers, rocks, pavement, planters, garden borders, overhanging branches, laundry lines, and electrical wires. (See OBSTACLE FREE SAFETY ZONE on cover)

CHOKING HAZARD/SHARP EDGES & POINTS

Adult assembly required. This product contains small parts and parts with sharp edges and points. Keep parts away from children until fully assembled.

WARNING LABEL

Owners shall be responsible for maintaining the legibility of the warning labels.

STRANGULATION HAZARD

- NEVER allow children to play with ropes, clotheslines, pet leashes, cables, chains or cord-like items when using this play-set or to attach these items to play-set.
- NEVER allow children to wear loose fitting clothing, ponchos, hoods, scarves, capes, necklaces, items with draw-strings, cords or ties when using this play-set.
- NEVER allow children to wear bike or sport helmets when using this play-set.

Failure to prohibit these items, even helmets with chin straps, increases the risk of serious injury and death to children from entanglement and strangulation.

TIP OVER HAZARD

Choose a level location for the equipment. This can reduce the likelihood of the play set tipping over and loose-fill surfacing materials washing away during heavy rains.

DO NOT allow children to play on the play-set until the assembly is complete and the unit is properly anchored.

Never add extra length to chain or rope. The chains or ropes provided are the maximum length designed for the swinging element(s).



WARNING – Safe Play Instructions

- ✓ Observe capacity limitations of your play-set. See front cover.
- ✓ Dress children with well fitting and full foot enclosing footwear.
- ✓ Teach children to sit with their full weight in the center of the swing seat to prevent erratic swing motion or falling off.
- ✓ Check for splintered, broken or cracked wood; missing, loose, or sharp edged hardware. Replace, tighten and or sand smooth as required prior to playing.
- ✓ Verify that suspended climbing ropes, rope ladders, chain or cable are secured at both ends and cannot be looped back on itself as to create an entanglement hazard.
- ✓ On sunny and or hot days, check the slide and other plastic rides to assure that they are not very hot as to cause burns. Cool hot slide and rides with water and wipe dry prior to using.
- ✓ Orientate slide such that it gets the least amount of exposure to the sun.
- ✗ Do not allow children to wear open toe or heel footwear like sandals, flip-flops or clogs.
- ✗ Do not allow children to walk, in front, between, behind or close to moving rides.
- ✗ Do not let children twist swing chains or ropes or loop them over the top support bar. This may reduce the strength of the chain or rope and cause premature failure.
- ✗ Do not let children get off rides while they are in motion.
- ✗ Do not permit climbing on equipment when it is wet.
- ✗ Do not permit rough play or use of equipment in a manner for which it was not intended. Standing on or jumping from the roof, elevated platforms, swings, climbers, ladders or slide can be dangerous.
- ✗ Do not allow children to swing empty rides or seats.
- ✗ Do not allow children to go down slide head first or run up slide.

! Protective Surfacing - Reducing Risk of Serious Head Injury From Falls

One of the most important things you can do to reduce the likelihood of serious head injuries is to install shock-absorbing protective surfacing under and around your play equipment. The protective surfacing should be applied to a depth that is suitable for the equipment height in accordance with ASTM F1292. There are different types of surfacing to choose from; whichever product you select, follow these guidelines:

Loose-Fill Materials

- Maintain a minimum depth of 9 inches (23 cm) of loose-fill materials such as wood mulch/chips, engineered wood fiber (EWF), or shredded/recycled rubber mulch for equipment up to 8 feet (2.45 m) high; and 9 inches (23 cm) of sand or pea gravel for equipment up to 5 feet (1.5 m) high. NOTE: An initial fill level of 12 inches (31 cm) will compress to about a 9-inch (23 cm) depth of surfacing over time. The surfacing will also compact, displace, and settle, and should be periodically raked and refilled to maintain at least a 9-inch (23 cm) depth.
- Use a minimum of 6 inches (16 cm) of protective surfacing for play equipment less than 4 feet (1.22 m) in height. If maintained properly, this should be adequate. (At depths less than 6 inches (16 cm), the protective material is too easily displaced or compacted.)

NOTE: Do not install home playground equipment over concrete, asphalt, or any other hard surface. A fall onto a hard surface can result in serious injury to the equipment user. Grass and dirt are not considered protective surfacing because wear and environmental factors can reduce their shock absorbing effectiveness. Carpeting and thin mats are not adequate protective surfacing. Ground level equipment -- such as a sandbox, activity wall, playhouse or other equipment that has no elevated play surface -- does not need any protective surfacing.

- Use containment, such as digging out around the perimeter and/or lining the perimeter with landscape edging. Don't forget to account for water drainage.
- Periodically rake, check and maintain the depth of the loose-fill surfacing material. Marking the correct depth on the play equipment support posts will help you to see when the material has settled and needs to be raked and or replenished. Be sure to rake and evenly redistribute the surfacing in heavily used areas.
- Do not install loose fill surfacing over hard surfaces such as concrete or asphalt.

Poured-In-Place Surfaces or Pre-Manufactured Rubber Tiles

You may be interested in using surfacing other than loose-fill materials - like rubber tiles or poured-in-place surfaces.

- Installations of these surfaces generally require a professional and are not "do-it yourself" projects.
- Review surface specifications before purchasing this type of surfacing. Ask the installer/manufacturer for a report showing that the product has been tested to the following safety standard: ASTM F1292 *Standard Specification for Impact Attenuation of Surfacing Materials within the Use Zone of Playground Equipment*. This report should show the specific height for which the surface is intended to protect against serious head injury. This height should be equal to or greater than the fall height - vertical distance between a designated play surface (*elevated surface for standing, sitting, or climbing*) and the protective surfacing below - of your play equipment.
- Check the protective surfacing frequently for wear.

Placement

Proper placement and maintenance of protective surfacing is essential. Refer to diagram on front cover. Be sure to;

- Extend surfacing at least 6 feet (1.8 m) from the equipment in all directions.
- For to-fro swings, extend protective surfacing in front of and behind the swing to a distance equal to twice the height of the top bar from which the swing is suspended.
- For tire swings, extend surfacing in a circle whose radius is equal to the height of the suspending chain or rope, plus 6 feet (1.8 m) in all directions.

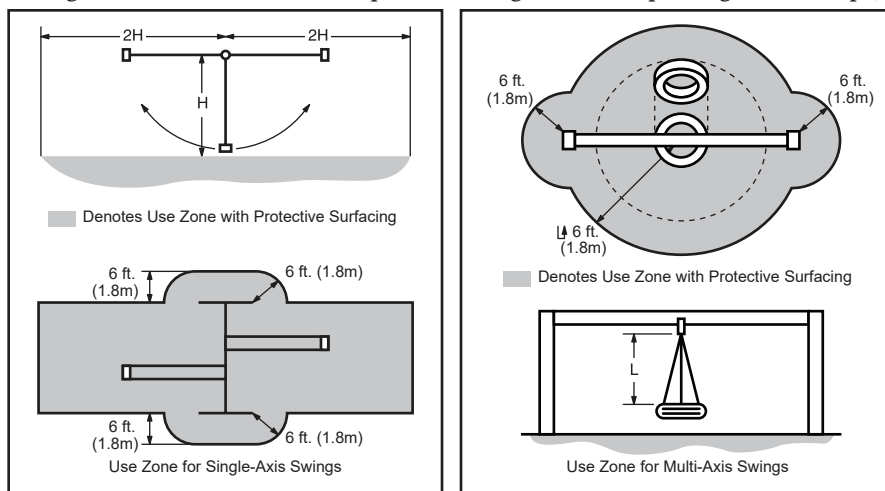

From the CPSC Outdoor Home Playground Safety Handbook. At <http://www.playgroundregs.com/resources/CPSC%20324.pdf>

Instructions for Proper Maintenance

Your KidKraft Play System is designed and constructed of quality materials with your child's safety in mind. As with all outdoor products used by children, it will weather and wear. To maximize the enjoyment, safety and life of your Play Set, it is important that you, the owner, properly maintain it.

Check the following at the beginning of the play season:

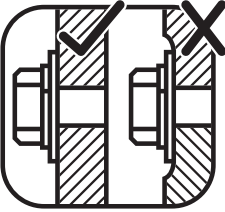
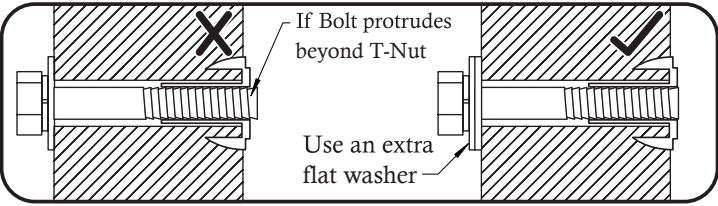
<p>HARDWARE:</p> <ul style="list-style-type: none"> ✓ Check metal parts for rust. If found, sand and repaint using a non-lead paint complying with 16 CFR 1303. ✓ Inspect and tighten all hardware. On wood assemblies DO NOT OVER-TIGHTEN as to cause crushing and splintering of wood. ✓ Check for sharp edges or protruding screw threads, add washers if required.  	<p>GROUND STAKES (ANCHORS):</p> <ul style="list-style-type: none"> ✓ Check for looseness, damage or deterioration. Should firmly anchor unit to ground during use. Re-secure and or replace, if necessary. <p>SWING HANGERS:</p> <ul style="list-style-type: none"> ✓ Check that bolts are secure and tight. Quick clips should be completely closed and threaded clips screwed tight. ✓ If squeaking occurs lubricate bushings with oil or WD-40®. <p>SWINGS, ROPES AND RIDES:</p> <ul style="list-style-type: none"> ✓ Reinstall if removed during cold season. Check all moving parts including swing seats, ropes, chains and attachments for wear, rust and other deterioration. Replace as needed. ✓ Check that ropes are tight, secure at both ends and cannot loop back as to create an entrapment. <p>WOOD PARTS:</p> <ul style="list-style-type: none"> ✓ Check all wood members for deterioration, structural damage and splintering. Sand down splinters and replace deteriorated wood members. As with all wood, some checking and small cracks in grain is normal. ✓ Applying a water repellent or stain (water-based) on a yearly basis is important maintenance to maintain maximum life and performance of the product.
<p>SHOCK ABSORBING SURFACING:</p> <ul style="list-style-type: none"> ✓ Check for foreign objects. Rake and check depth of loose fill protective surfacing materials to prevent compaction and maintain appropriate depth. Replace as necessary. (See Protective Surfacing, page 4) 	

Check twice a month during play season:

<p>HARDWARE:</p> <ul style="list-style-type: none"> ✓ Inspect for tightness. Must be firmly against, but not crushing the wood. DO NOT OVER-TIGHTEN. This will cause splintering of wood. ✓ Check for sharp edges or protruding screw threads. Add washers if required. 	<p>SHOCK ABSORBING SURFACING:</p> <ul style="list-style-type: none"> ✓ Rake and check depth of loose fill protective surfacing materials to prevent compaction and maintain appropriate depth. Replace as necessary. (See Protective Surfacing, page 4)
---	---

Check once a month during play season:

<p>SWING HANGERS:</p> <ul style="list-style-type: none"> ✓ Check that they are secure and orientated correctly. Hook should rotate freely and perpendicular to support beam. ✓ If squeaking occurs lubricate bushings with oil or WD-40®. 	<p>SWINGS AND RIDES:</p> <ul style="list-style-type: none"> ✓ Check swing seats, all ropes, chains and attachments for fraying, wear, excessive corrosion or damage. Replace if structurally damaged or deteriorated.
--	---

Check at the end of the play season:

<p>SWINGS AND RIDES:</p> <ul style="list-style-type: none"> ✓ To prolong their life, remove swings and store inside when outside temperature is below 32°F/0°C. Below freezing, plastic parts may become more brittle. 	<p>SHOCK ABSORBING SURFACING:</p> <ul style="list-style-type: none"> ✓ Rake and check depth of loose fill protective surfacing materials to prevent compaction and maintain appropriate depth. Replace as necessary. (See Protective Surfacing, page 4)
--	---

If you dispose of your play set: Please disassemble and dispose of your unit so that it does not create any unreasonable hazards at the time it is discarded. Be sure to follow your local waste ordinances.

About Our Wood

KidKraft Premium Play Systems uses only premium playset lumber, ensuring the safest product for your children's use. Although we take great care in selecting the best quality lumber available, wood is still a product of nature and susceptible to weathering which can change the appearance of your set.

What causes weathering? Does it affect the strength of my Play System?

One of the main reasons for weathering is the effects of water (moisture); the moisture content of the wood at the surface is different than the interior of the wood. As the climate changes, moisture moves in or out of the wood, causing tension which can result in checking and or warping. You can expect the following due to weathering. These changes will not affect the strength of the product:

1. **Checking** is surface cracks in the wood along the grain. A post 4" x 4" (101mm x 101mm) will experience more checking than a board 1" x 4" (25mm x 101mm) because the surface and interior moisture content will vary more widely than in thinner wood.
2. **Warping** results from any distortion (twisting, cupping) from the original plane of the board and often happens from rapid wetting and drying of the wood.
3. **Fading** happens as a natural change in the wood color as it is exposed to sun-light and will turn a grey over time.

How can I reduce the amount of weathering to my Play System?

At the factory we have coated the wood with a water repellent or stain. This coating decreases the amount of water absorption during rain or snow thus decreasing the tension in the wood. Sunlight will break down the coating, so we recommend applying a water repellent or stain on a yearly basis (see your local stain and paint supplier for a recommended product).

Most weathering is just the normal result of nature and will not affect safe play and enjoyment for your child. However if you are concerned that a part has experienced a severe weathering problem please call our consumer relations department for further assistance.

Complete and mail registration card to receive important product notifications and assure prompt warranty service.

KidKraft Limited Warranty

MISSING OR DAMAGED PARTS:

KidKraft will replace any parts within 90 days from date of purchase found to be missing from or damaged in the original packaging. See Fig.1

Fig. 1	<u>Product Age (All Parts)</u> 0-90 Days from date of purchase	<u>Consumer Pays</u> \$0 for Part + Free Shipping
--------	---	--

DEFECTS IN MATERIAL AND WORKMANSHIP:

KidKraft warrants that this product is free from defects in materials and workmanship for a period of one (1) year from the original date of purchase (dated sales receipt and/or product registration is required). This one (1) year warranty covers all parts including wood, hardware, and all accessories (Such as swings, rides, and slides). See Fig. 2

Fig. 2	<u>Product Age (All Parts)</u> 91 Days to 1 Year	<u>Consumer Pays</u> \$0 for Part + Free Shipping
--------	---	--

WOOD ROT, DECAY, AND INSECT DAMAGE:

All wood carries a five (5) year warranty against rot, decay, and insect damage (dated sales receipt and/or product registration is required). Refer to the schedule below for charges associated with replacement of wood parts under this **Limited Warranty**. See Fig. 3

Fig. 3	<u>Product Age (Wood Parts)</u> 0 Days to 1 Year After 1 Year to 5 Year Over 5 Years	<u>Consumer Pays</u> \$0 for Part + Free Shipping \$0 for Part + Shipping & Handling 100% for Part (if available) + Shipping & Handling
--------	---	--

This warranty applies to the original owner and registrant and is non-transferable. Regular maintenance is required to ensure the integrity of this product. Failure by the owner to maintain the product according to the maintenance requirements may void this warranty.

This Limited Warranty does NOT cover:

- Any inspection cost
- Labor and/or costs for replacement of any defective item(s), including but not limited to, professional installer costs
- Incidental or consequential damages, including but not limited to, as a result of set relocation, move and/or reinstall
- Cosmetic defects which do not affect performance or integrity of a part or the entire product
- Vandalism, improper use or installation, or acts of nature, including but not limited to, high winds, fire, and flood
- Minor twisting, warping, checking, or any natural occurring properties of wood that do not affect performance or integrity.
- Any KidKraft product purchased, including but not limited to, a non-approved retailer, auction houses, second-hand, and as-is clearance items.

KidKraft products have been designed for safety and quality. Modifications made to the original product may damage the structural integrity of the unit leading to failure and possible injury. KidKraft cannot assume any responsibility for the modified products. Furthermore, modifications void all warranties.

This product is warranted for **RESIDENTIAL USE ONLY**. Under no circumstance should a KidKraft product be used in public settings such as schools, churches, playgrounds, parks, home and professional day cares and the like. Such use may lead to product failure and potential injury. Public use will void this warranty. KidKraft disclaims all other representations and warranties of any kind, express or implied.

Keys to Assembly Success

Tools Required

<ul style="list-style-type: none"> • Tape Measure • Carpenters Level • Carpenters Square • Claw Hammer • Standard or Cordless Drill • Rubber Mallet 	<ul style="list-style-type: none"> • #1 Phillips, #2 Robertson and Screwdriver • Ratchet with extension 1/2" (13mm) & 7/16" (11 mm) sockets 	<ul style="list-style-type: none"> • Open End Wrench 1/2" (13mm) & 7/16" (11 mm) • Adjustable Wrench • 1/8" (3mm) & 3/16" (5mm) Drill Bits 	<ul style="list-style-type: none"> • 3/16" (5mm) Hex Key • 8' (2.4m) Step Ladder • Safety Glasses • Adult Helpers • Pencil
---	---	---	---

Part Identification Key

On each page, you will find the parts and quantities required to complete the assembly step illustrated on that page. Here is a sample.

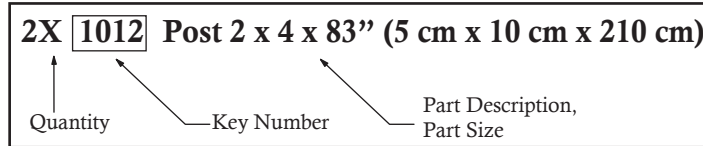

Symbols

Throughout these instructions symbols are provided as important reminders for proper and safe assembly.

<p>This identifies information that requires special attention. Improper assembly could lead to an unsafe or dangerous condition.</p>	<p>Check that set or assembly is properly level before proceeding.</p> <p>Use Level</p>
<p>Use Help</p> <p>Where this is shown, 2 or 3 people are required to safely complete the step. To avoid injury or damage to the assembly make sure to get help!</p>	<p>Pre-drill 1/8" (3mm) & 3/16" (5mm) Bit</p> <p>Pre-drill a pilot hole before fastening screw or lag to prevent splitting of wood.</p>
<p>Measure Distance</p> <p>Use a measuring tape to assure proper location.</p>	<p>Tighten Bolts</p> <p>This indicates time to tighten bolts, but not too tight! Do not crush the wood. This may create splinters and cause structural damage.</p>
<p>Use Help</p> <p>Check that assembly is square before tightening bolts.</p>	<p>Square Assembly</p>

CAUTION – Protrusion Hazard

Once the assembly is tightened, watch for exposed threads. If a thread protrudes from the T-Nut, remove the bolt and add washers to eliminate this condition. Extra washers have been provided for this purpose.

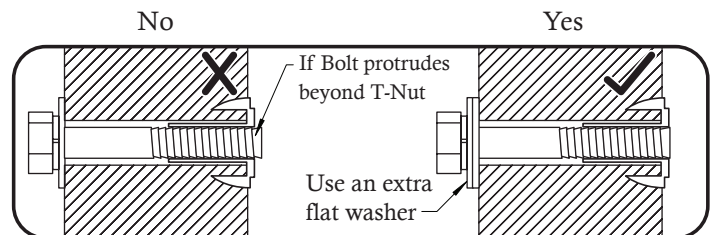

Proper Hardware Assembly

Lag screws require drilling pilot holes to avoid splitting wood. Only a flat washer is required. For ease of installation liquid soap can be used on all lag-type screws.

For bolts, tap T-Nut into hole with hammer. Insert the hex bolt through lock washer first then flat washer then hole. Because the assemblies need to be squared do not completely tighten until instructed. Pay close attention to diameter of the bolts. 5/16" (8mm) is slightly larger than 1/4" (6.4mm).

Note: Wafer head bolts with blue lock tight or a bolt with a Ny-Lok nut do NOT require a lock washer.

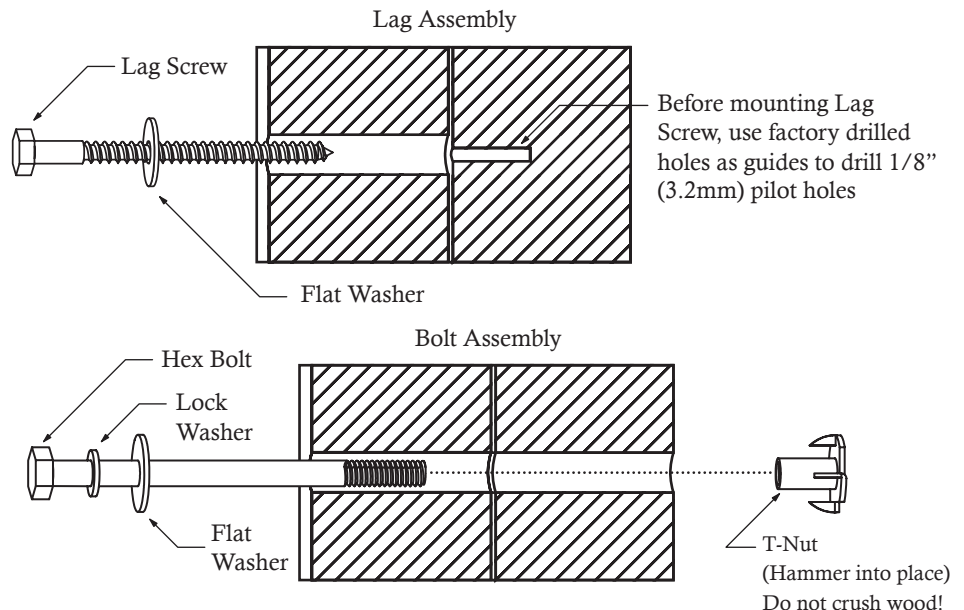

Part Identification (Reduced Part Size)

Nominal Size	Actual Size
5/4 x 5	15/16 x 4-1/4
5/4 x 6	15/16 x 5-1/4
2 x 2	1-1/2 x 1-1/2
1 x 4	5/8 x 3-3/8
1 x 6	5/8 x 5-3/8
1-1/4 x 2-1/4	1-1/4 x 2-1/4
1-1/4 x 3	1-1/4 x 3
4 x 4	3 x 3
4 x 6	3 x 5-1/4

1pc. - [2648] - 1 x 4 x 40-5/8" - Floor Board - **3632648**
 15.9 mm x 85.7 mm x 1031.9 mm

8pc. - [2609] - 1 x 5 x 40-5/8" - Floor Board - **3632609**
 15.9 mm x 114.3 mm x 1031.9 mm

2pc. - [2605] - 1 x 6 x 19-3/4" - Access Board - **3632605**
 15.9 mm x 133.4 mm x 501.7 mm

2pc. - [2717] - Clock Block 3/4 x 1-3/4 x 9-3/4"
 - **3632717**
 19.1 mm x 44.5 mm x 247.7 mm

2pc. - [2603] - 1 x 6 x 19-3/4" - Rock Board A - **3632603**
 15.9 mm x 133.4 mm x 501.7 mm

3pc. - [2604] - 1 x 6 x 19-3/4" - Rock Board B - **3632604**
 15.9 mm x 133.4 mm x 501.7 mm

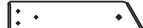
2pc. - [2606] - 5/4 x 4 x 14 1/4" - SW Ground - **3632606**
 23.8 mm x 82.6 mm x 362 mm

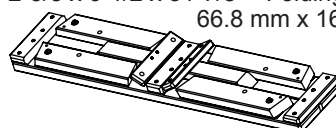
1pc. - [9501] - 2-5/8 x 6-1/2 x 31-7/8" - Folding Bench - **37639501**
 66.8 mm x 165.1 mm x 809.6 mm



1pc. - [2611] - 5/4 x 5 x 39-5/8" - Table Top - **3632611**
 23.8 mm x 108 mm x 1006.5 mm

1pc. - [2612] - 2 x 2 x 39-5/8" - Table Support - **3632612**
 38.1 mm x 38.1 mm x 1006.5 mm

2pc. - [2647] - 1-1/4 x 3 x 10" - Roof End Left - **3632647**
 31.8 mm x 76.2 mm x 254 mm

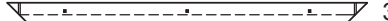
2pc. - [2610] - 2 x 2 x 40-1/4" - Side Joist - **3632610**
 38.1 mm x 38.1 mm x 1022.4 mm

4pc. - [2617] - 1-1/4 x 2-1/4 x 37-1/2" - Roof Support - **3632617**
 31.8 mm x 57.2 mm x 952.5 mm

2pc. - [0349] - Rock Rail 2 x 3 x 51" - **3640349**
 34.9 mm x 63.5 mm x 1295.4 mm

1x - Door Hardware (3201710)

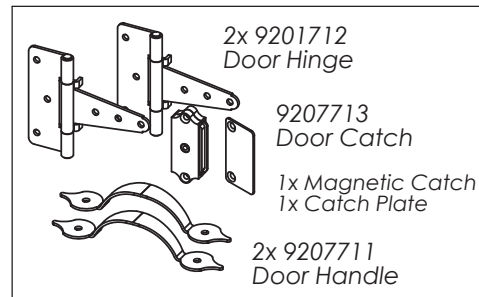

1pc. - [2616] - 5/4 x 4 x 46-1/2" - SW Support - **3632616**
 23.8 mm x 82.6 mm x 1181.1 mm

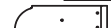
2pc. - [2646] - 1-1/4 x 3 x 10" - Roof End - **3632646**
 31.8 mm x 76.2 mm x 254 mm

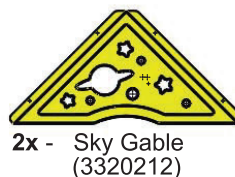

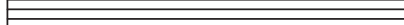

2pc. - [2607] - 1-1/4 x 3 x 22" - Diagonal - **3632607**
 31.8 mm x 76.2 mm x 558.8 mm

1pc. - [2602] - Upper Jamb 1 1/4 x 3 x 35-15/16" - **3632602**
 31.8 mm x 76.2 mm x 912.8 mm

2pc. - [2601] - Lower Jamb 1 1/4 x 3 x 41-15/16" - **3632601**
 31.8 mm x 76.2 mm x 1065.2 mm

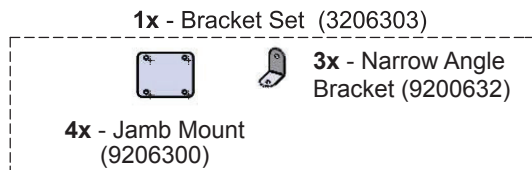
1pc. - [2608] - 1-1/4 x 3 x 40-3/4" - Floor Joist - **3632608**
 31.8 mm x 76.2 mm x 1035.1 mm



2pc. - [2613] - 2 x 3 x 86-11/16" - Heavy SW Post - **3632613**
 50.8 mm x 76.2 mm x 2201.9 mm

1pc. - [2615] - 4 x 4 x 50-15/16" - SW Upright - **3632615**
 76.2 mm x 76.2 mm x 1294.3 mm

1pc. - [2614] - 4 x 6 x 88" - Engineered Beam - **3632614** 76.2 mm x 133.4 mm x 2235.2 mm

1x - Cafe Canopy Set (3754900)

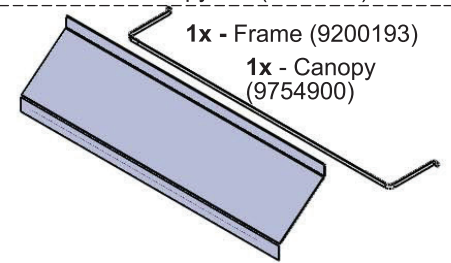

1x - Glider Hanger (2pk) (3200105)

1x - Kidkraft Logo Plaque (3320353)

2x - Long Belt Swing (3724947) Yellow

1x - ID Plaque (9320371)

1x - Base Clock (9320124)



1x - Rocks (5pk) (3320386)

1x - Clock Subset (3320329)

6x - Rebar Ground Stake (9290318)

1x - Space Glider Body (3320268) Yellow



2x - Space Glider Handle (3320177) Green

1x 3533863 - 39" Glider Rope - EN71 (4pk)



1x - Beam Bracket Left (9200144)

2x - L Beam Bracket (9200145)

4x - Swing Hanger (9200106)

1x - Beam Bracket Right (9200143)

Part Identification (Reduced Part Size)

2pc. - **[2618]** Front Back
 Panel 1¼ x 42 x 87" - 37632618
 31.8 mm x 1066 mm x 2209 mm

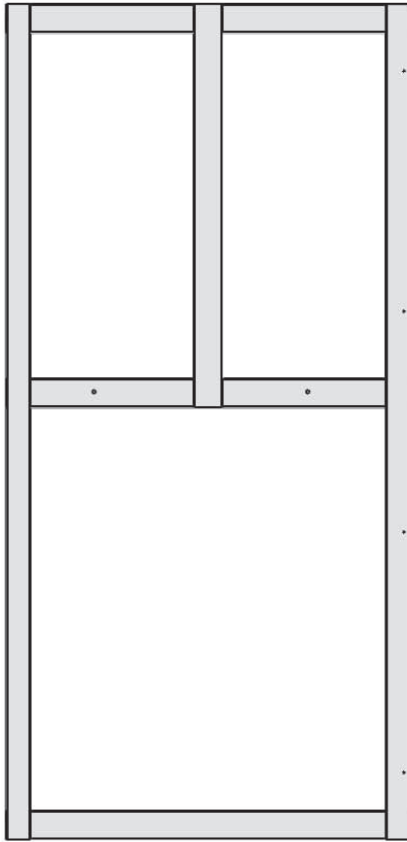

1pc. - **[2627]**
 SW Wall Panel 1¼ x 42 x 87" - 37632627
 31.8 mm x 1066 mm x 2209 mm

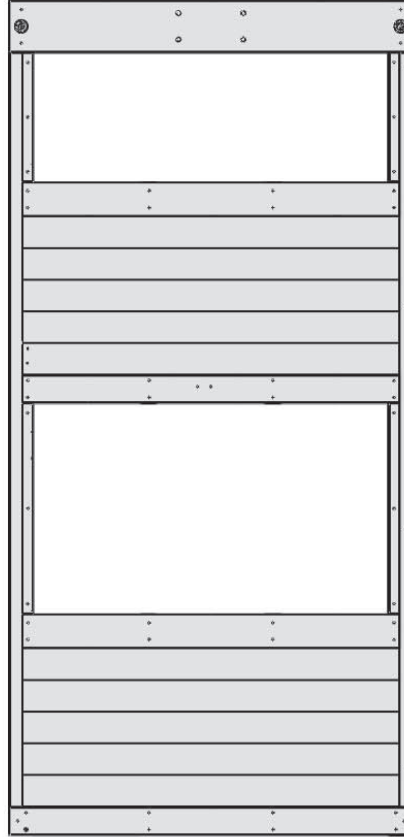

1pc. - **[2639]**
 Back Roof Panel 1¼ x 36¾ x 44" - 37632639
 31.8 mm x 933.5 mm x 1117 mm

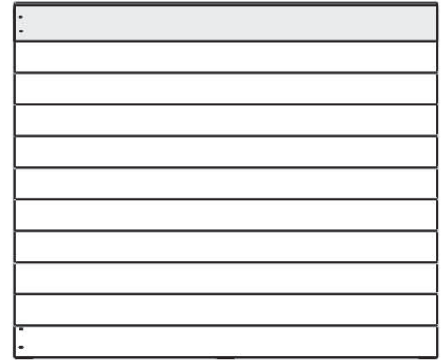

1pc. - **[2644]**
 Front Roof Panel 1¼ x 37 x 44" - 37632644

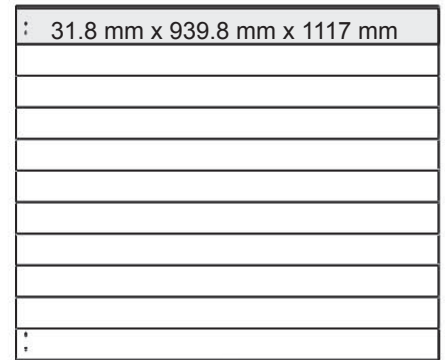

2pc. - **[2655]**
 Upper Window Insert
 1.27 x 18.8 x 35.86" - 37632655
 32.3 mm x 477.5 mm x 910.8 mm

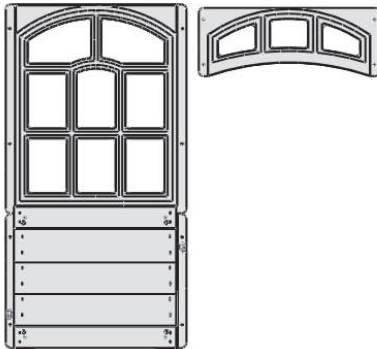

1pc.
 MOD 3 Pane Transom (2Pk)
 - 3320138



2pc. - **[649A]**
 Short Half Wall - 1.27 x 18.8 x 20-15/16" - 37632649A
 32.3 mm x 457.2 mm x 531.8 mm

1pc. - **[2665]**
 Half Wall Insert - 1.4 x 20¼ x 38.8" - 37632665
 35.6 mm x 514.4 mm x 985.5 mm

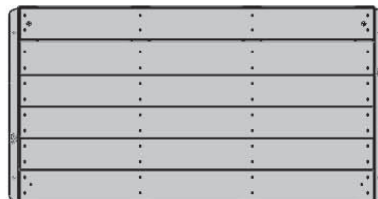

1pc. - **[2622]**
 End Panel Assembly 1¼ x 42 x 87" - 37632622
 31.8 mm x 1066 mm x 2209 mm

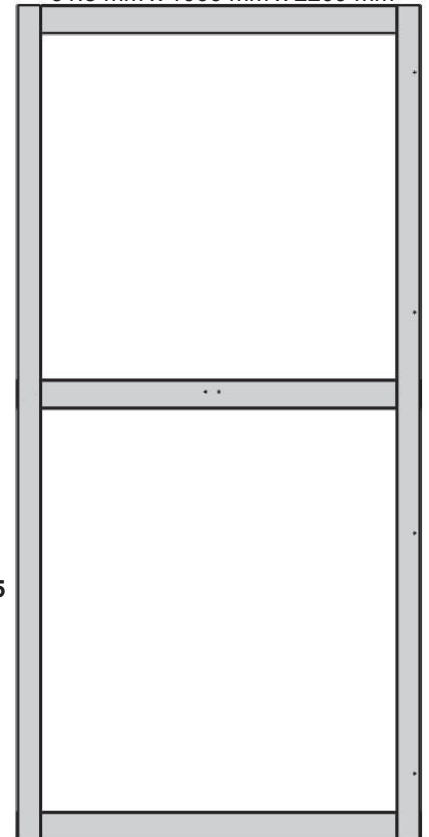

2pc. - **[2649]**
 Lower Window Insert
 1.27 x 18.8 x 41.91" - 37632649

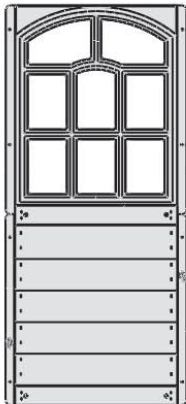

32.3 mm x 477.5 mm x 1064 mm

Part Identification (Reduced Part Size)

8934 (1) SL Gusset 1 1/4 x 3 x 15 3/4" - 3638934
31.8 mm x 76.2 mm x 700 mm

8965 (1) TNR Upright 1 1/4 x 3 x 20 1/4" - 3638965
31.8 mm x 76.2 mm x 514.4 mm

8963 (1) TNR Ground Brace 1 1/4 x 3 x 32 1/4" - 3638963
31.8 mm x 76.2 mm x 819.2 mm

8935 (1) Lower SL Insert 1.36 x 8-1/8 x 26 1/4"
37638935
34.5 mm x 206.4 mm x 666.8 mm

2709 (1) Door Window Panel
1 1/4 x 15 3/4 x 40 3/4" 37602709B
31.8 mm x 400 mm x 1035 mm

2715 (1) Door Stop 5/4 x 3 x 10" - 3632715
31.8 mm x 76.2 mm x 254 mm

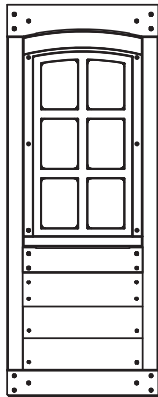

Part Identification (Actual Part Size)

54pc. PB1 - Pan Bolt 1/4 x 3/4" - (53453203)
6.4 x 19.1mm

11pc. PB6 - Pan Bolt 1/4 x 1" - (53413210)
6.4 x 25.4mm

8pc. FW6 - #12 Screw Bezel - (9299500)

64pc. LN1 - 1/4 Lock Nut - (54303200)
6.4mm

1pc. H8 - Hex Bolt 1/4 x 4 1/4" - (53703241)
6.4 x 108mm

1pc. S37 - Pan Screw #7 x 5/8" - (52433009)
15.9mm

1x D1 - Quadrex Driver Bit (9200015)

(2) Jamb Mount (9206300)

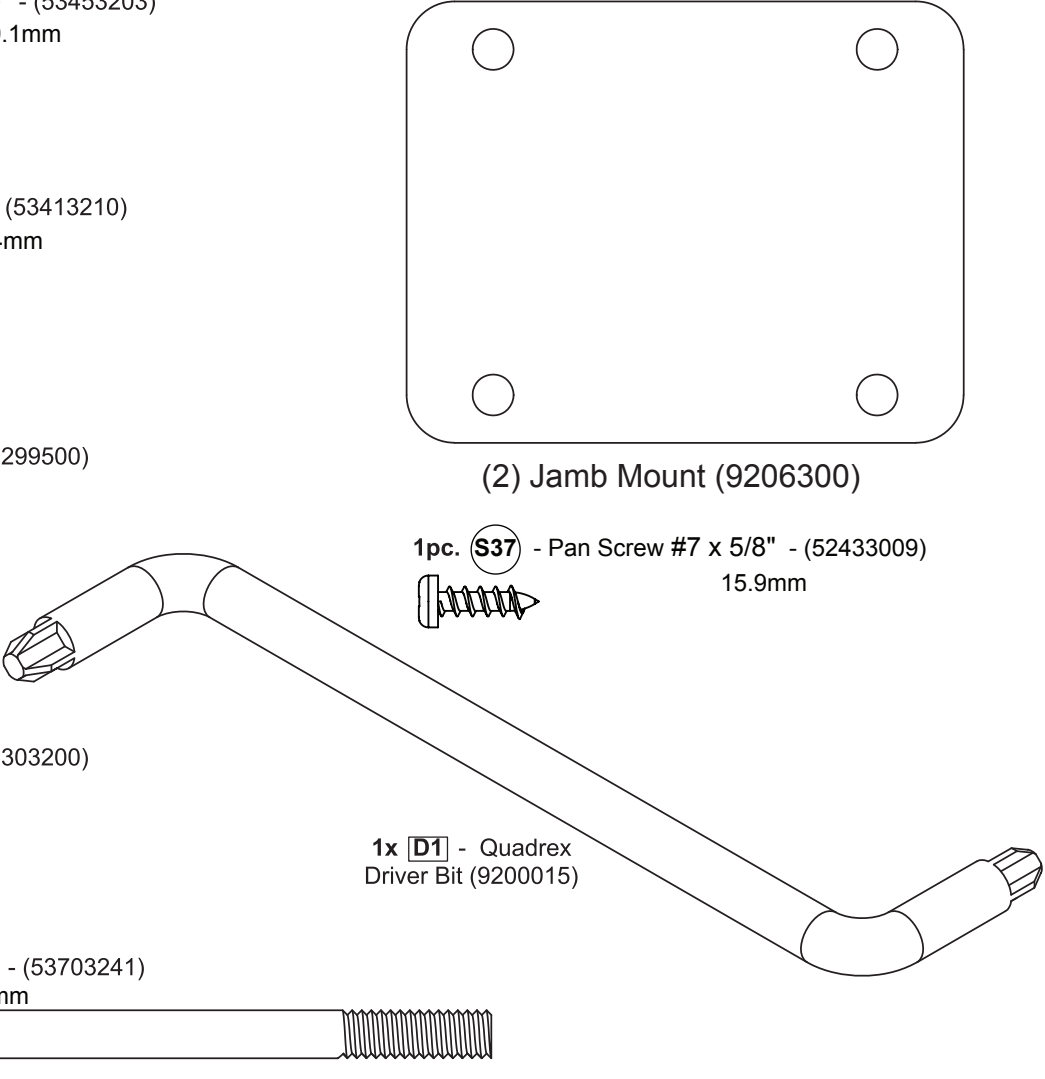

Hardware Identification (Actual Size)

5pc. **LW2** - 5/16" Lock Washer - (51303300)
7.9mm



5pc. **FW0** - 3/16" Flat Washer - (51103100)
4.8mm

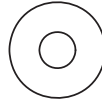

11pc. **TN1** - 1/4" T - Nut
(54503200) 6.4mm

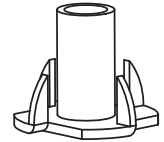

16pc. **LW1** - 1/4" Lock Washer - (51303200)
6.4mm



16pc. **FW1** - 1/4" Flat Washer - (51103200)
6.4mm

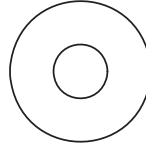

8pc. **TN2** - 5/16" T- Nut - (54503300)
7.9mm

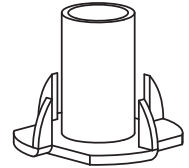

29pc. **LN2** - 5/16" Lock Nut - (54303300)
7.9mm

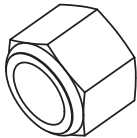

66pc. **FW2** - 5/16" Flat Washer - (51103300)
7.9mm

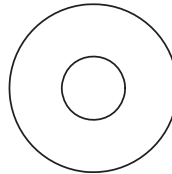

5pc. **BN1** - 1/4" Barrel Nut - (54803200)
6.4mm

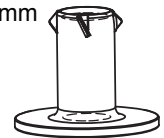

5pc. **PB2** - Pan Bolt 1/4 x 1-1/4" - (53433212)
6.4 x 31.8mm

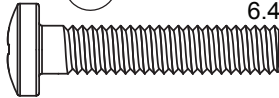

26pc. **FW3** - #8 Flat Washer - (51003500)



1pc. **D4** - 2 x 2 Robertson Driver Bit - (9200014)
50.8mm

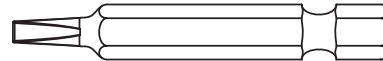

104pc. **S0** - Truss Screw #8 x 7/8" - (52933505)
22.2mm

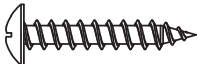

16pc. **S13** - Pan Screw #6 x 5/8" - (52413908)
16mm

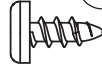

36pc. **S5** - Pan Screw #8 x 1/2" - (52433502)
12.7mm

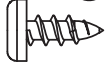

8 pc. **S18** - Wood Screw #6 x 1" - (52013910)
25.4mm



5pc. **S10** - Pan Screw #8 x 1" - (52433510)
25.4mm

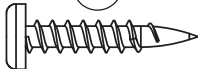

53pc. **S2** - Wood Screw #8 x 1-1/2" - (52043512)
38.1mm



21pc. **S6** - Pan Screw #12 x 1" - (52433610)
25.4mm

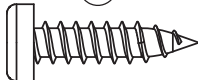

34 pc. **S11** - Wood Screw #8 x 2" - (52043520)
50.8mm



28pc. **S42** - Pan Screw #12 x 1-1/2" - (52433621)
38.1mm

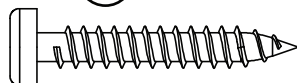

14pc. **S3** - Wood Screw #8 x 2-1/2" - (52043522)
63.5mm



15pc. **S7** - Pan Screw #12 x 2" - (52433620)
50.8mm

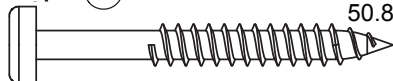

13pc. **S4** - Wood Screw #8 x 3" - (52043530)
76.2mm



Hardware Identification (Actual Size)

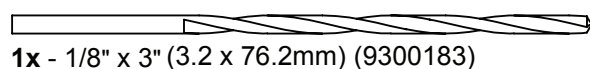
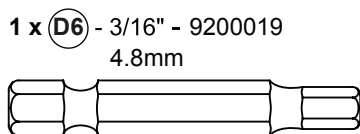
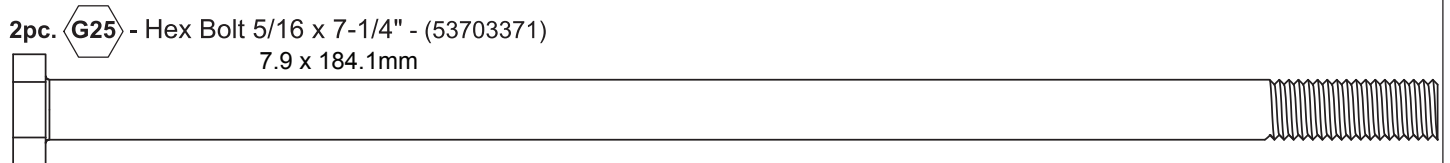
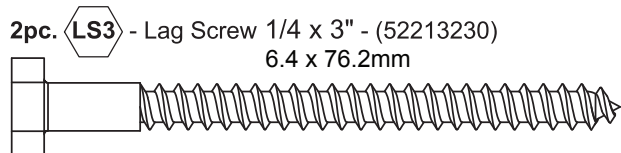
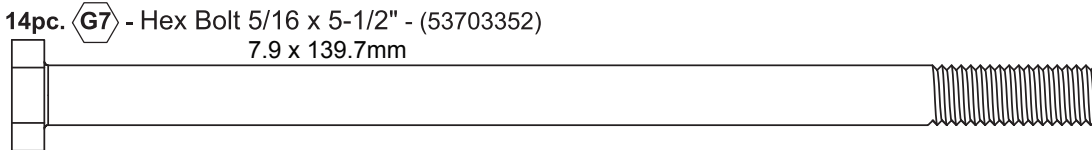
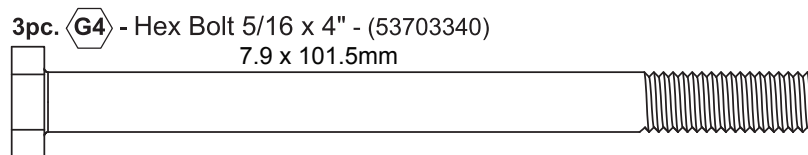
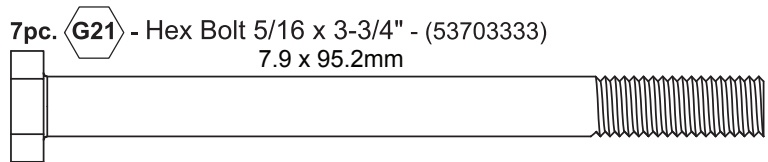
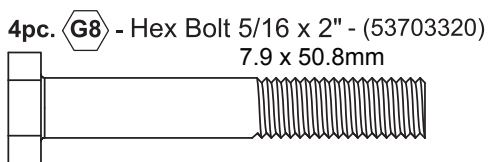
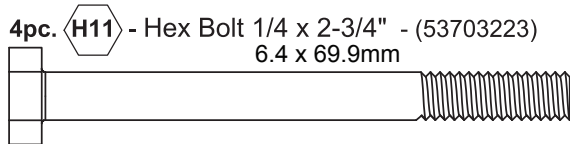
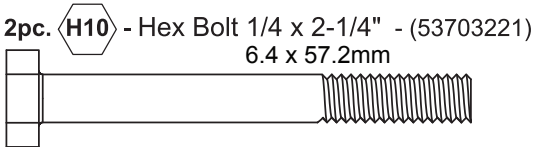
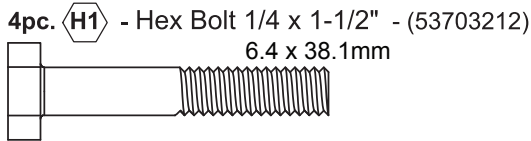
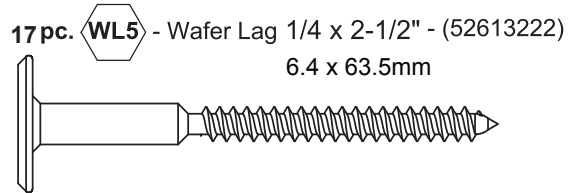
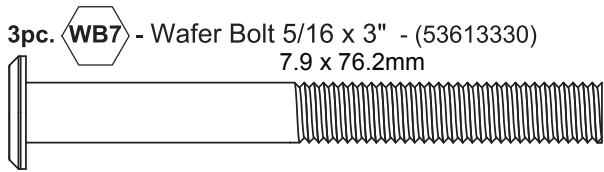

Part Identification (Reduced Part Size)

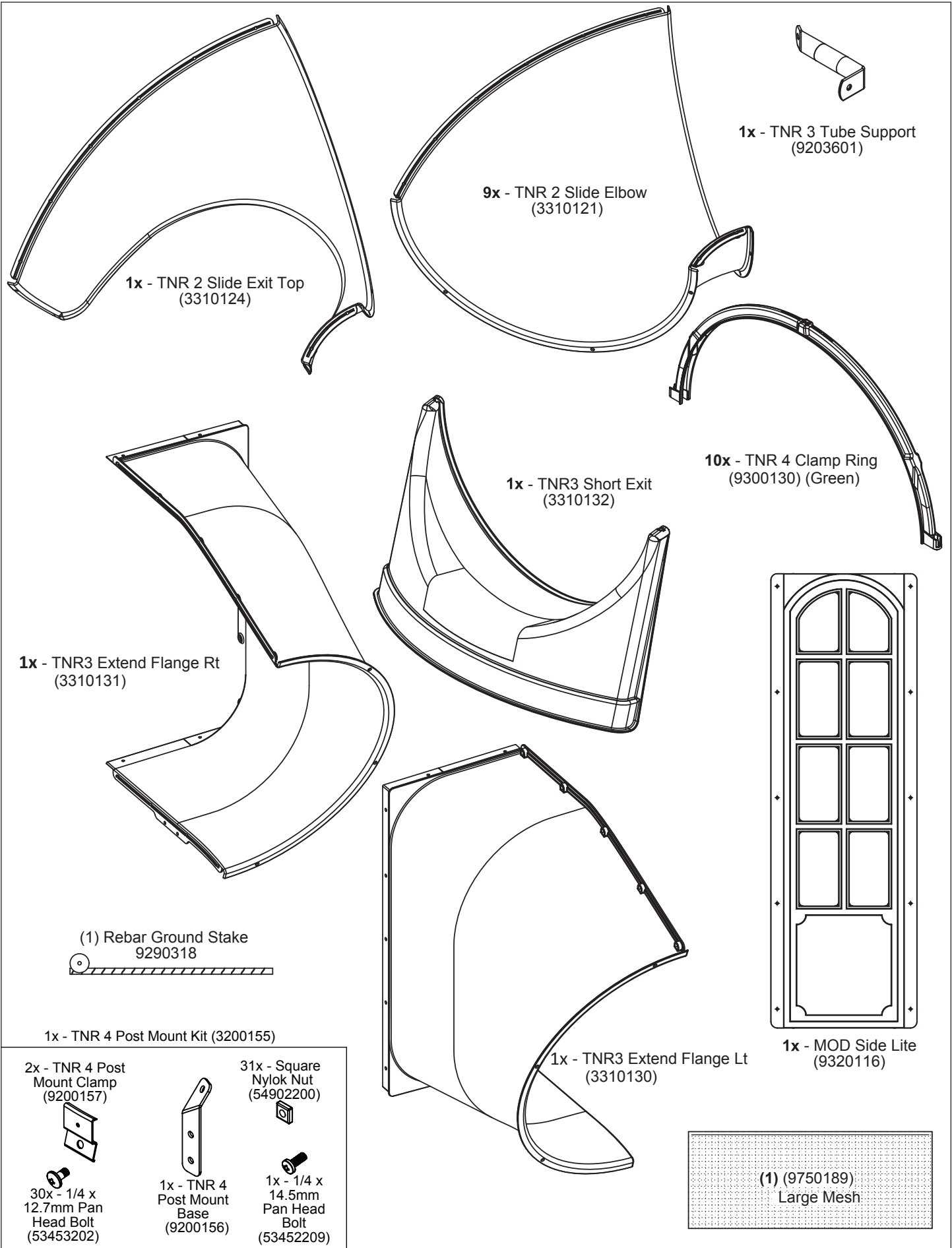

1 Inventory Parts - Read This Before Starting Assembly

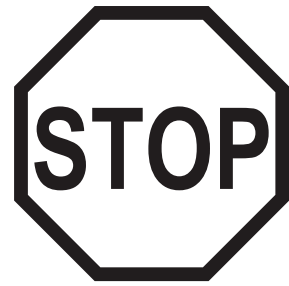
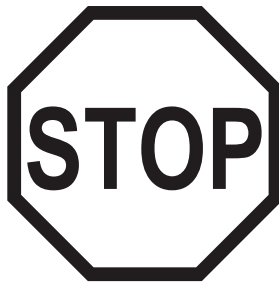
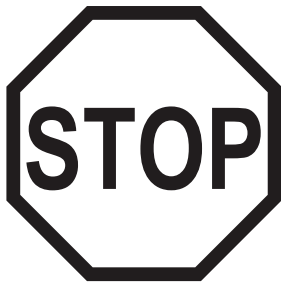

Inventory should be completed before starting installation. KidKraft will not cover costs of any additional installation trip due to missing or damaged pieces.

A. This is the time for you to inventory all your hardware, wood and accessories, referencing the parts identification sheets. This will assist you with your assembly.

- The wood pieces will have the key number stamped on the ends of the boards. Organize the wood pieces by step, as per the key numbering system below.

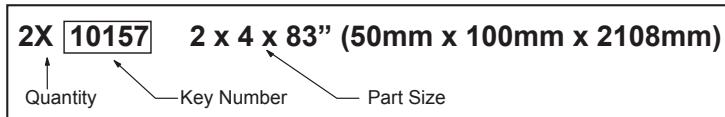

B. Read the assembly manual completely, paying special attention to ANSI warnings; notes; and safety/maintenance information on pages 1 - 8.

**If there are missing or damaged pieces,
please contact the KidKraft Consumer Engagement team
before going back to the retailer.**

Order Replacement Parts 24/7

You can order replacement parts for this product 24 hours a day / 7 days a week:

Outdoor Swingsets and Playhouse Parts Ordering

<https://parts.kidkraft.com/partsorderemail>

If you have assembly or product questions, please refer to the front cover for direct contact information for our Consumer Engagement team OR you can also use this QR code with your smartphone for common questions and contact information.

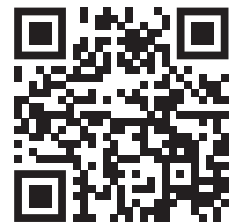

KidKraft Help Center **<https://kidkraft.zendesk.com/hc/en-us/>**

Step 2: Frame Assembly Part 1



It is important to assemble the frame on a flat, smooth surface.

A: Place (2627) SW Wall Panel between 2 (2618) Front Back Panels noticing the panel orientations. The tops and bottoms of the panels should be flush. Make sure the panels are square then using the pilot holes as a guide pre-drill with a 3 mm drill bit and fasten the front (2618) Front Back Panel to (2627) SW Wall Panel and (2627) SW Wall Panel to the back (2618) Front Back Panel with 4 (WL5) Wafer Lags per side. (fig. 2.1, 2.2 and 2.3)

Fig. 2.1
Top View

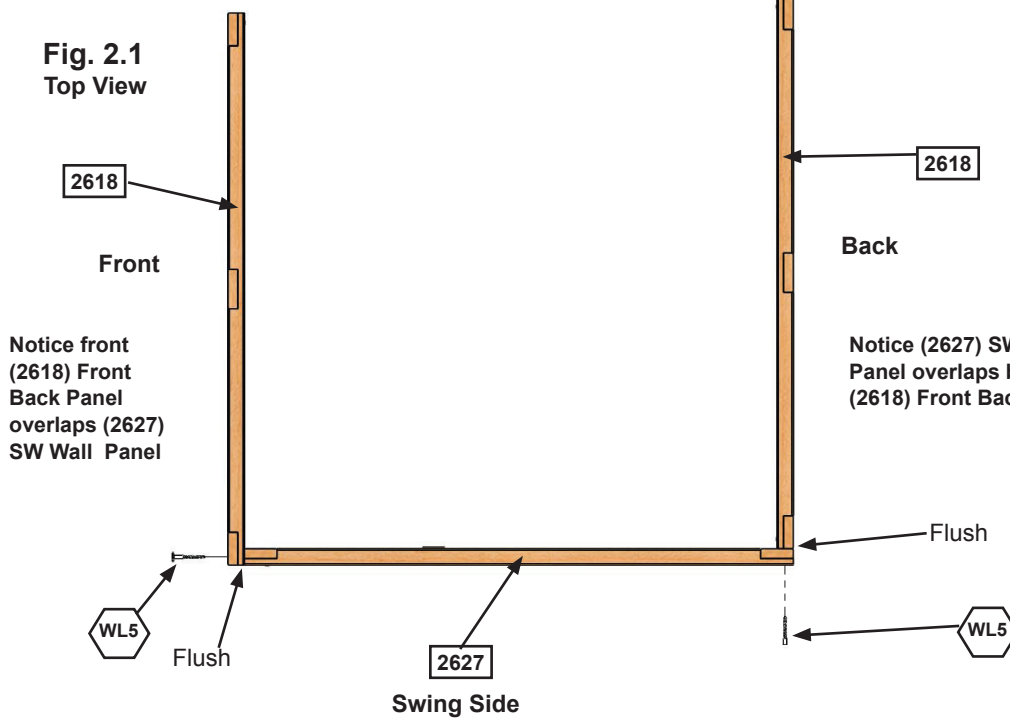

Fig. 2.3

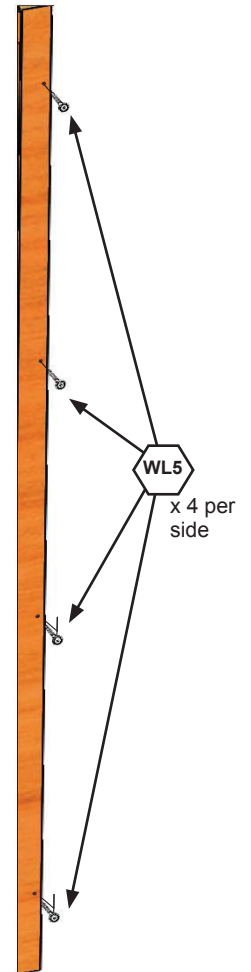
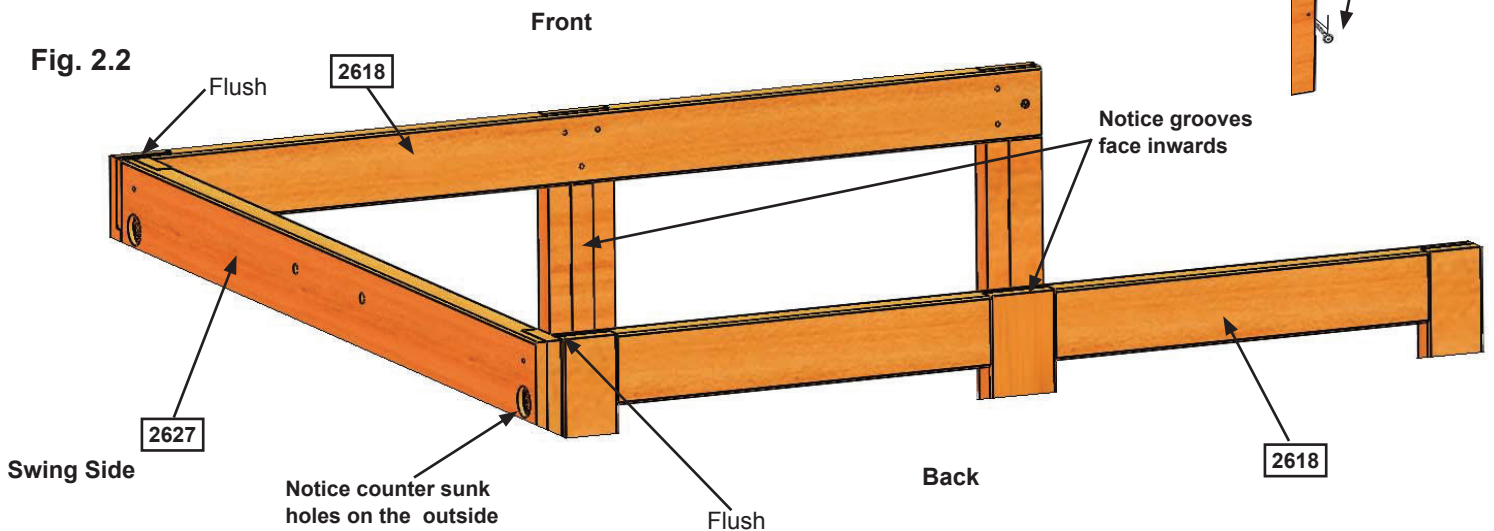

Fig. 2.2



Wood Parts

- 2 x 2618 Front Back Panel 31.8 mm x 1066.8 mm x 2209.8 mm
- 1 x 2627 SW Wall Panel 31.8 mm x 1066.8 mm x 2209.8 mm

Hardware

- 8 x WL5 6.4 x 63.5mm Wafer Lag

Step 2: Frame Assembly Part 2



B: Place (2622) End Panel Assembly between both (2618) Front Back Panels noticing the panel orientations. The tops and bottoms of the panels should be flush. Make sure the panels are square then using the pilot holes as a guide pre-drill with a 3 mm drill bit and fasten the back (2618) Front Back Panel to (2622) End Panel Assembly and (2622) End Panel Assembly to the front (2618) Front Back Panel with 4 (WL5) Wafer Lags per side. (fig. 2.4)

Fig. 2.4

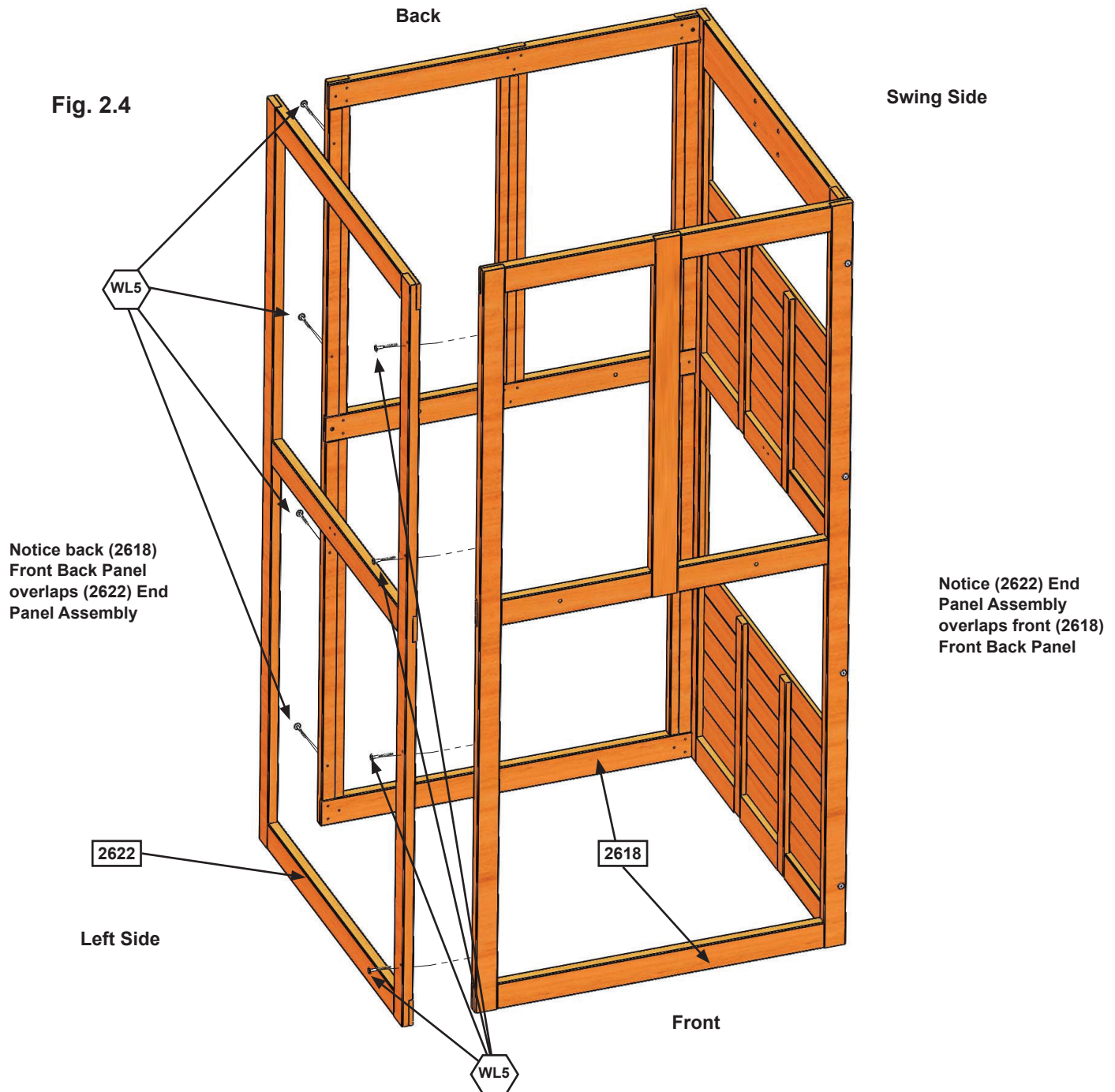

Wood Parts

1 x **2622** End Panel Assembly 31.8 mm x 1066.8 mm x 2209.8 mm

Hardware

8 x **WL5** 6.4 x 63.5mm Wafer Lag

Step 3: Floor Assembly Part 1



A: From inside of the assembly centre (2608) Floor Joist over pilot holes in (2622) End Panel Assembly and (2627) SW Wall Panel, 15.9 mm down from the top of board then attach (2608) Floor Joist to each panel with 2 (S4) Wood Screws per end. (fig.3.1, 3.2 and 3.3)

Fig. 3.1
Top View

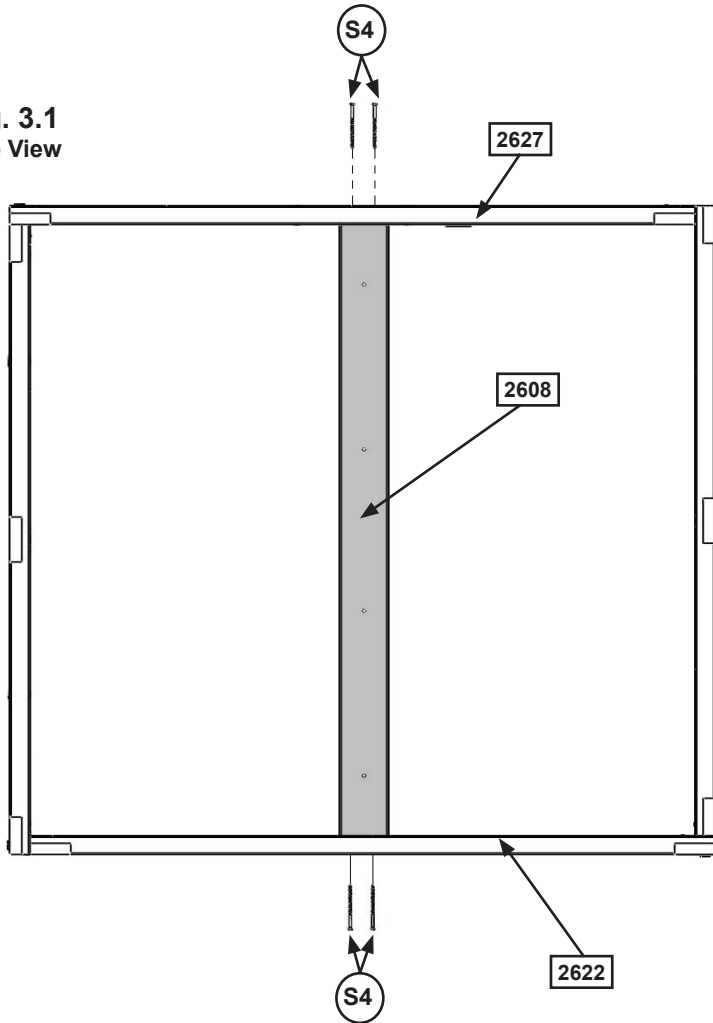

Fig. 3.3

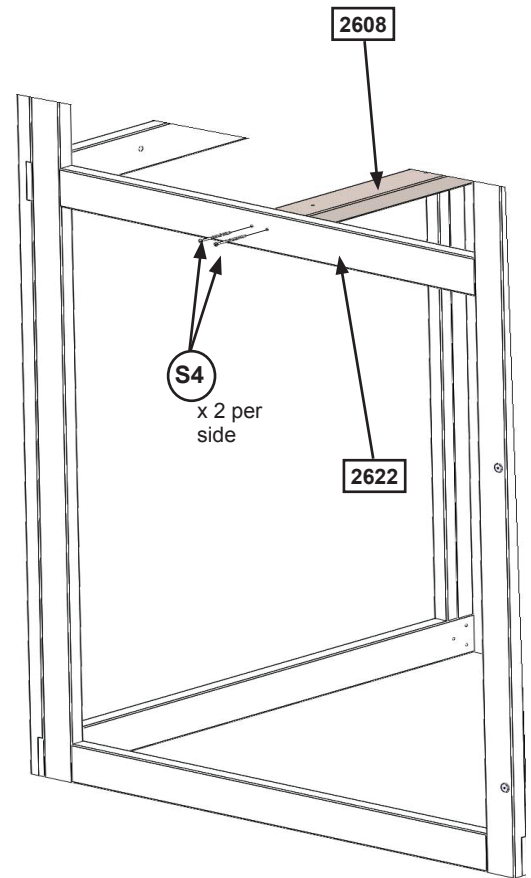
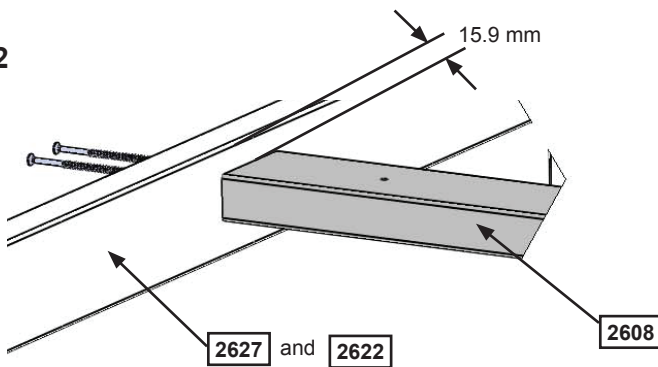

Fig. 3.2



Wood Parts

1 x 2608 Floor Joist 31.8 mm x 76.2 mm x 1035.1 mm

Hardware

4 x S4 #8 x 76.2mm Wood Screw

Step 3: Floor Assembly Part 2



B: On both (2618) Front Back Panels attach 1 (2610) Side Joist to the inside of each panel with 2 (H11) Hex Bolts (with lock washer, flat washer and t-nut) and 4 (S3) Wood Screws as shown in fig. 3.4 and 3.5.

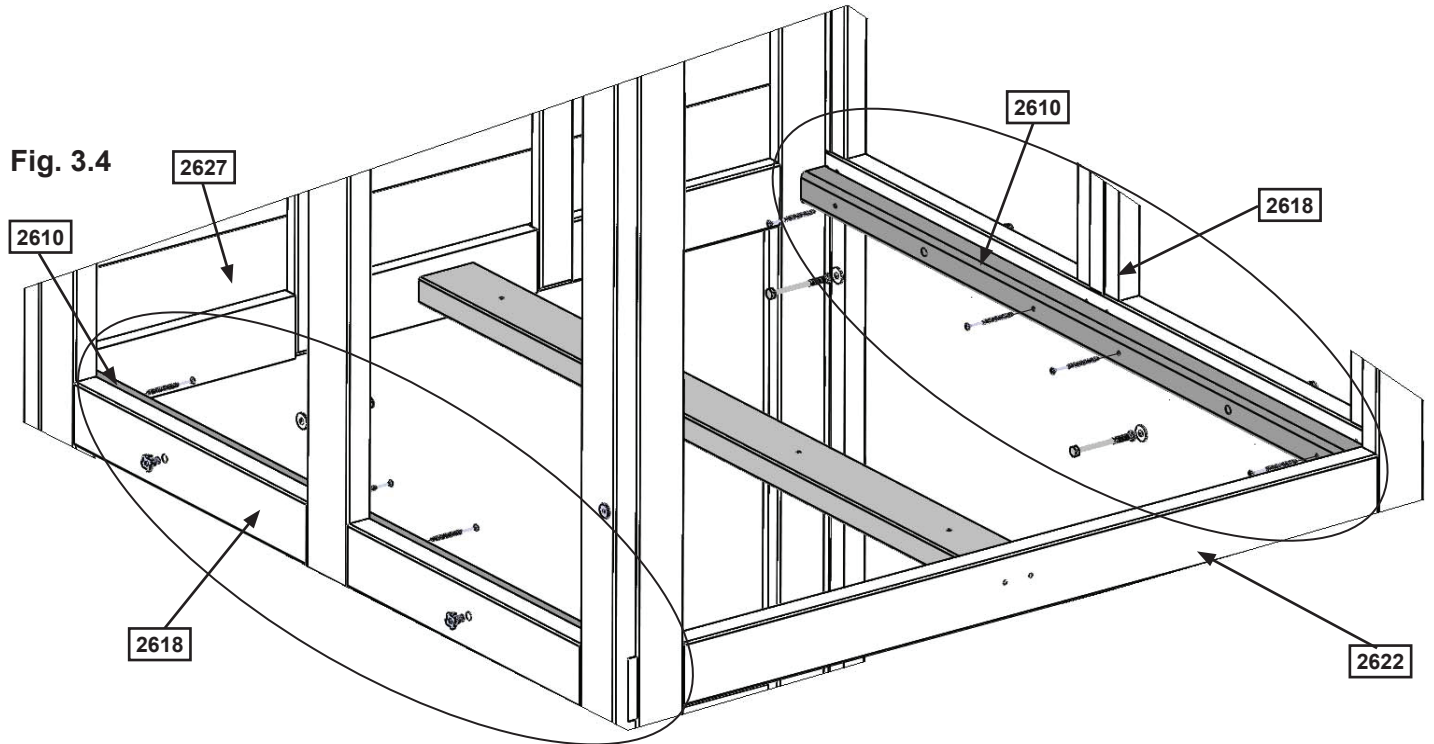

Note: Install T-nuts first!

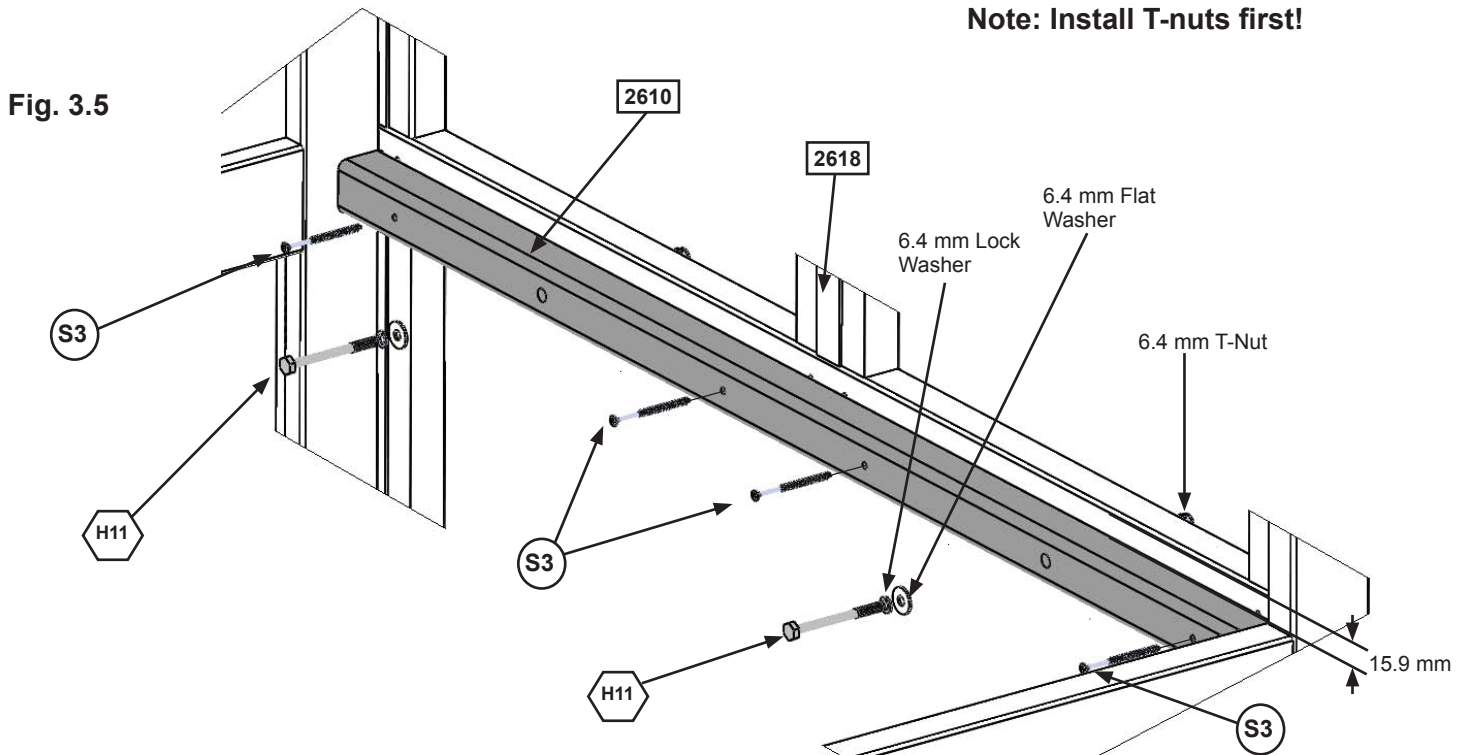

Wood Parts

2 x 2610 Side Joist 38.1 mm x 38.1 mm x 1022.4 mm

Hardware

8 x S3 #8 x 63.5mm Wood Screw

4 x H11 6.4 x 69.9mm Hex Bolt
(6.4 mm lock washer, 6.4 mm flat washer, 6.4 mm t-nut)

Step 3: Floor Assembly Part 3

C: Starting at (2627) SW Wall Panel place (2648) Floor Board followed by 8 (2609) Floor Boards. Make sure all boards are evenly spaced then attach to (2608) Floor Joist and each (2610) Side Joist with 5 (S2) Wood Screws per board. (fig. 3.6 and 3.7)

Fig. 3.6

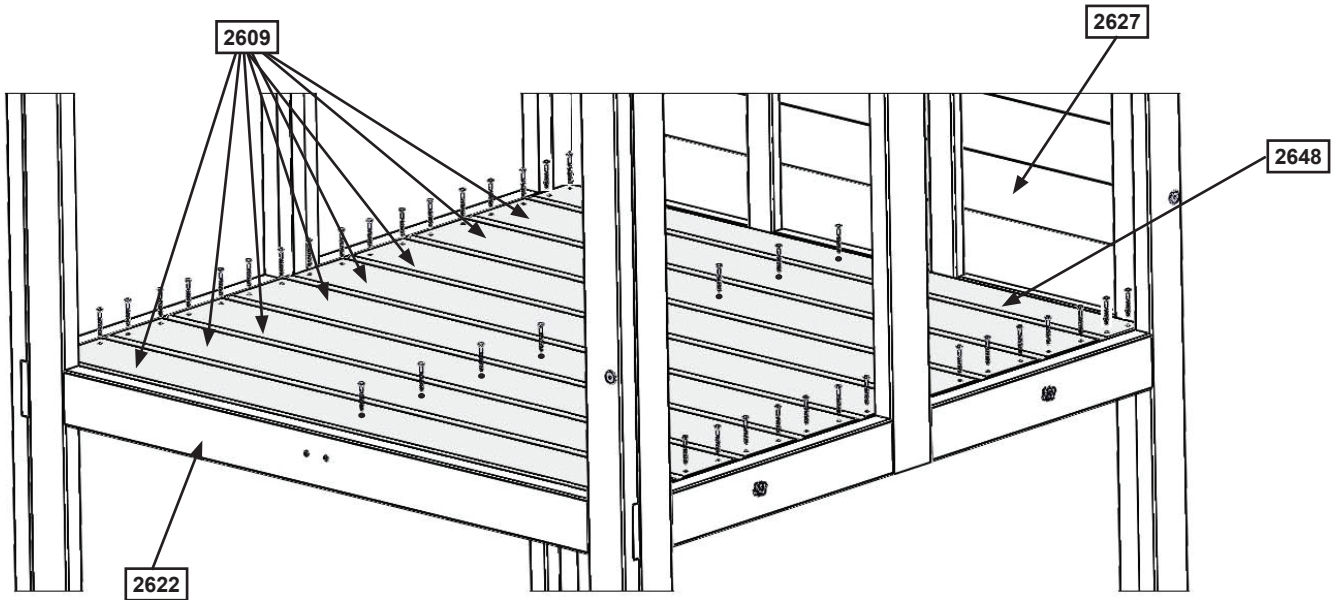
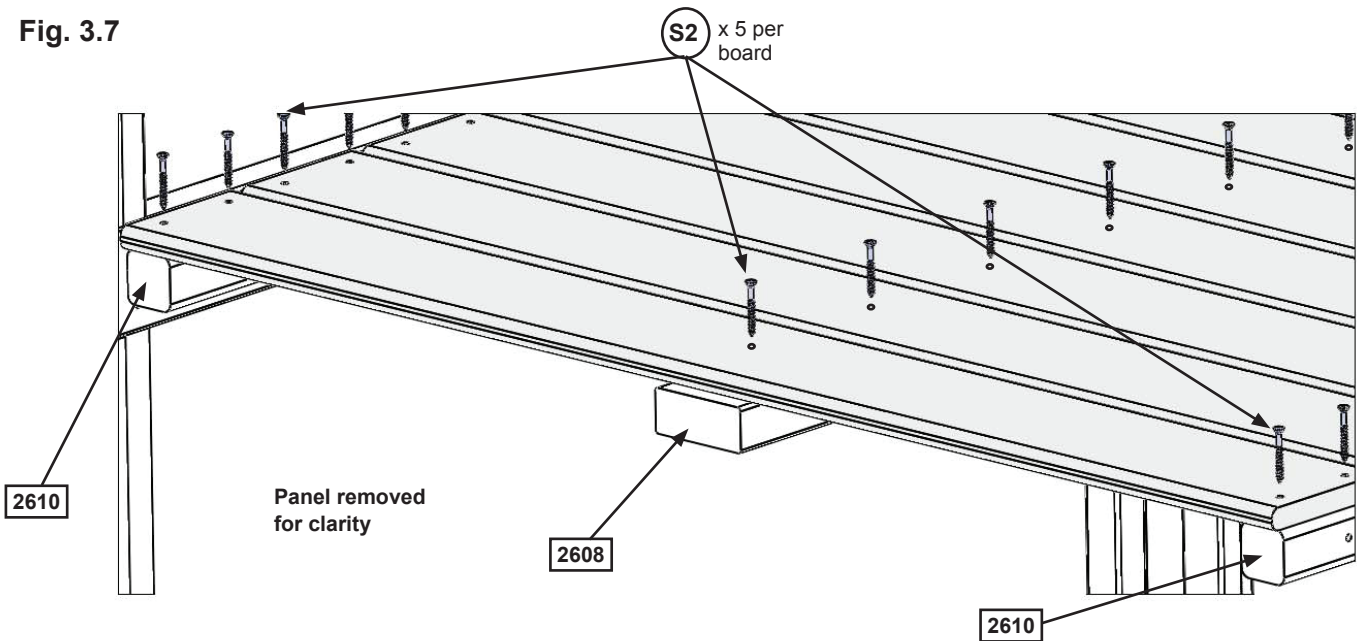

Fig. 3.7



Wood Parts

- 1 x 2648 Floor Board 15.9 mm x 85.7 mm x 1031.9 mm
- 8 x 2609 Floor Board 15.9 mm x 114.3 mm x 1031.9 mm

Hardware

- 45 x S2 #8 x 38.1mm Wood Screw

Step 4: Attach SW Ground and Diagonal



A: Loosely attach 1 (2606) SW Ground to each (2607) Diagonal with 1 (H10) Hex Bolt (with lock washer, flat washer and t-nut) per board then place each (2607) Diagonal tight and flush to the front of (2627) SW Wall Panel. (2606) SW Grounds to be flush to the bottom of (2627) SW Wall Panel. (fig. 4.1 and 4.2)

B: Pre-drill pilot hole with a 3 mm drill bit then attach each (2607) Diagonal to (2627) SW Wall Panel with 1 (LS3) Lag Screw (with flat washer) per board, checking that they remain flush to outside edge. (fig. 4.1 and 4.2)

C: Make sure bottom of each (2606) SW Ground is flush to bottom of (2627) SW Wall Panel then attach with 2 (S11) Wood Screws and 1 (S4) Wood Screw per board. Tighten all bolts. (fig. 4.1 and 4.2)

Fig. 4.1

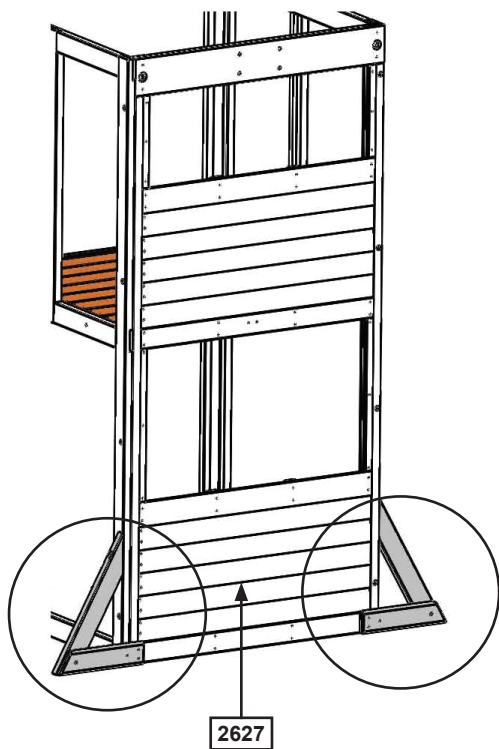

Note: Install T-nuts first!

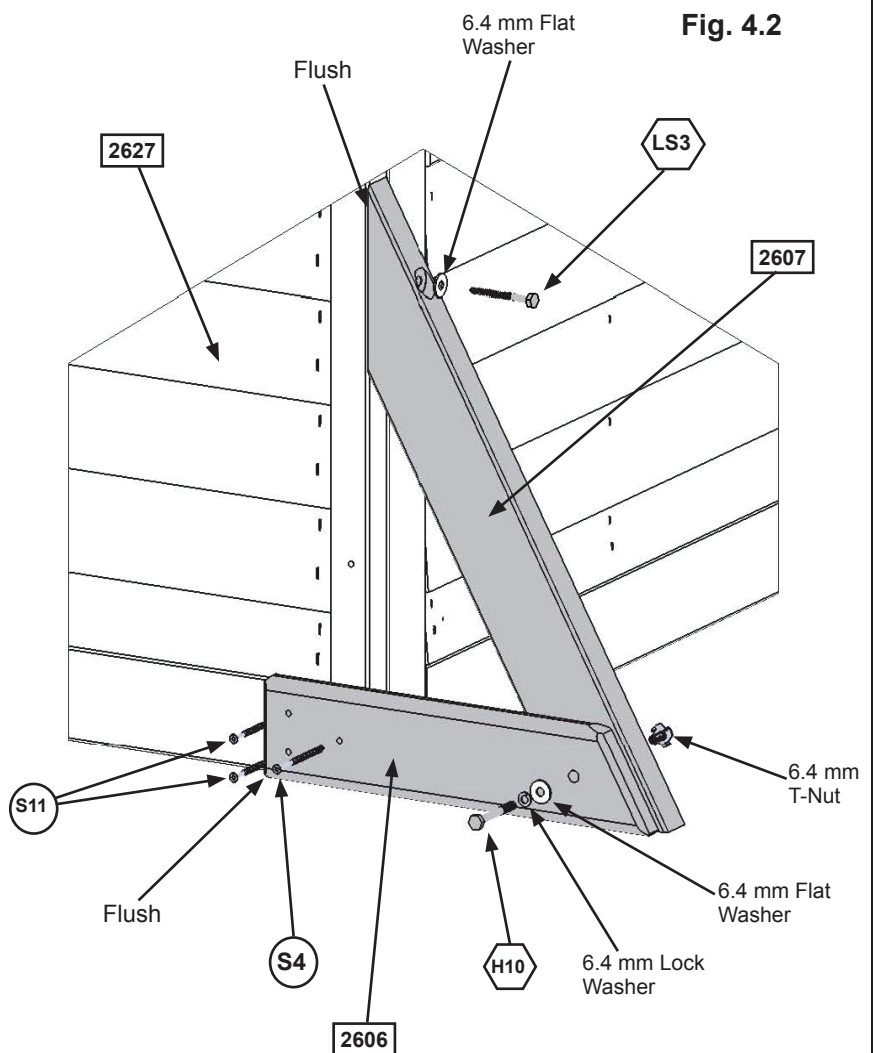

Wood Parts	
2 x	2606 SW Ground 23.8 mm x 82.6 mm x 362 mm
2 x	2607 Diagonal 31.8 mm x 76.2 mm x 558.8 mm

Hardware	
2 x	H10 6.4 x 57.2mm Hex Bolt (6.4 mm lock washer, 6.4 mm flat washer, 6.4 mm t-nut)
2 x	LS3 6.4 x 76.2mm Lag Screw (6.4 mm flat washer)
2 x	S4 #8 x 76.2mm Wood Screw
4 x	S11 #8 x 50.8mm Wood Screw

Step 5: Swing Beam Assembly

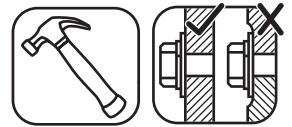

A: Attach 4 Swing Hangers to Fort End of (2614) Engineered Beam and 2 Glider Hangers to the Glider End using 2 (G7) Hex Bolts (with 2 flat washers and 1 lock nut) per Swing Hanger and Glider Hanger, as shown in fig. 5.1.

B: Flush to the Fort End of (2614) Engineered Beam attach 2 L-Beam Brackets with 2 (G21) Hex Bolts (with 2 flat washers and 1 lock nut). (fig. 5.2)

C: Install 1 (WB7) Wafer Bolt (with flat washer and t-nut) in the middle bolt hole in (2614) Engineered Beam as shown in fig. 5.3. **IT IS IMPORTANT THAT THIS BOLT IS ATTACHED. IT WILL MINIMIZE CHECKING OF WOOD.**

D: Attach KidKraft Plaque to centre of (2614) Engineered Beam (over top of t-nut) using 4 (S18) Wood Screws. (fig. 5.4)

Fig. 5.1

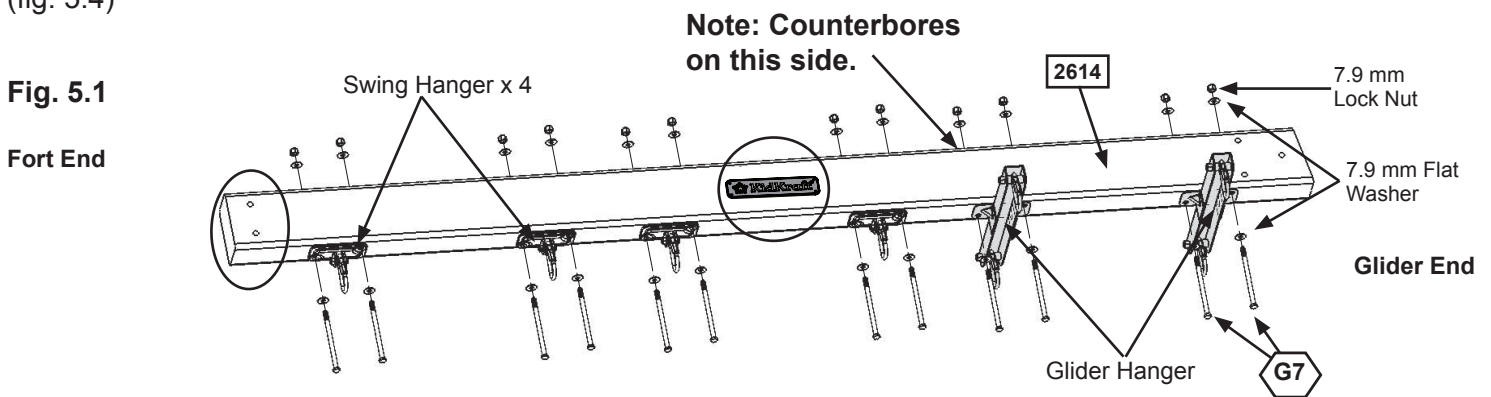
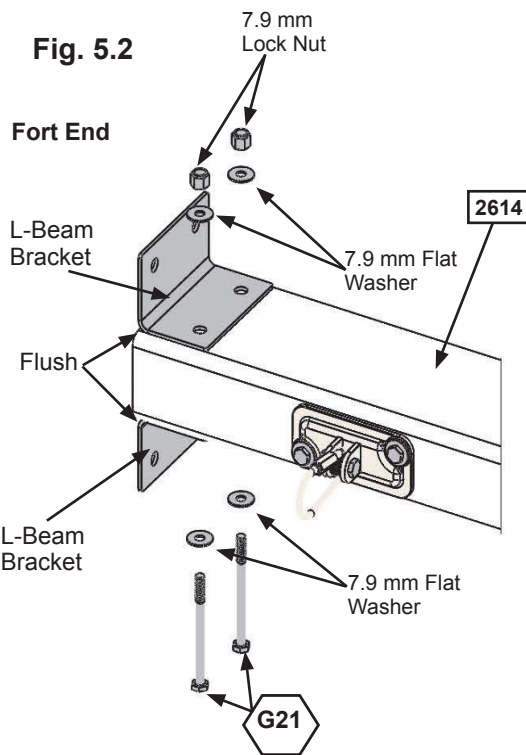

Fig. 5.2



Note: Install T-nuts first!

Fig. 5.3

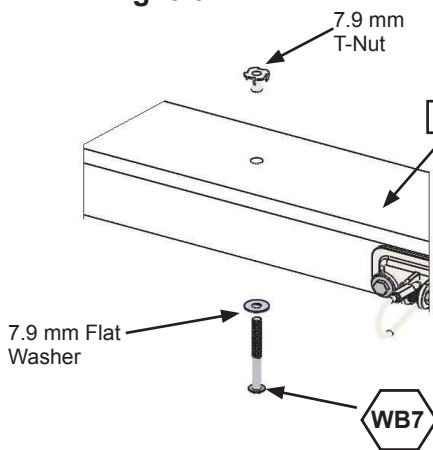
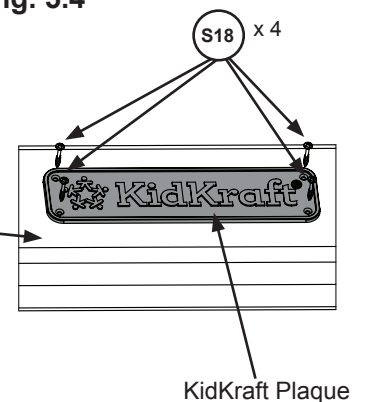

Fig. 5.4



Wood Parts

1 x **2614** Engineered Beam
76.2 mm x 133.4 mm x 2235.2 mm

Hardware

12 x **G7** 7.9 x 139.7mm Hex Bolt (7.9 mm flat washer x 2, 7.9 mm lock nut)
2 x **G21** 7.9 x 95.2mm Hex Bolt (7.9 mm flat washer x 2, 7.9 mm lock nut)
1 x **WB7** 7.9 x 76.2mm Wafer Bolt (7.9 mm flat washer & 7.9 mm t-nut)
4 x **S18** #6 x 25.4mm Wood Screw

Other Parts

4 x Swing Hangers
2 x Glider Hanger
2 x L-Beam Bracket
1 x KidKraft Plaque

Step 6: Swing End Assembly

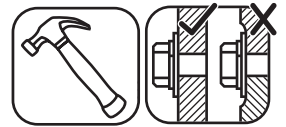

A: Loosely attach 2 (2613) Heavy SW Posts to (2615) SW Upright using 2 (G7) Hex Bolts (with lock washer, flat washer and t-nut). Notice 2 bolt holes at top of (2615) SW Upright and orientation of angle. (fig. 6.1)

B: Attach (2616) SW Support to both (2613) Heavy SW Posts and (2615) SW Upright using 3 (G4) Hex Bolts (with lock washer, flat washer and t-nut). Tighten all bolts (fig. 6.1)

C: Install 2 (WB7) Wafer Bolts (with flat washer and t-nut) in the top bolt holes in (2615) SW Upright as shown in fig. 6.1. **IT IS IMPORTANT THAT THESE BOLTS ARE ATTACHED. THEY WILL MINIMIZE CHECKING OF WOOD.**

Fig. 6.1

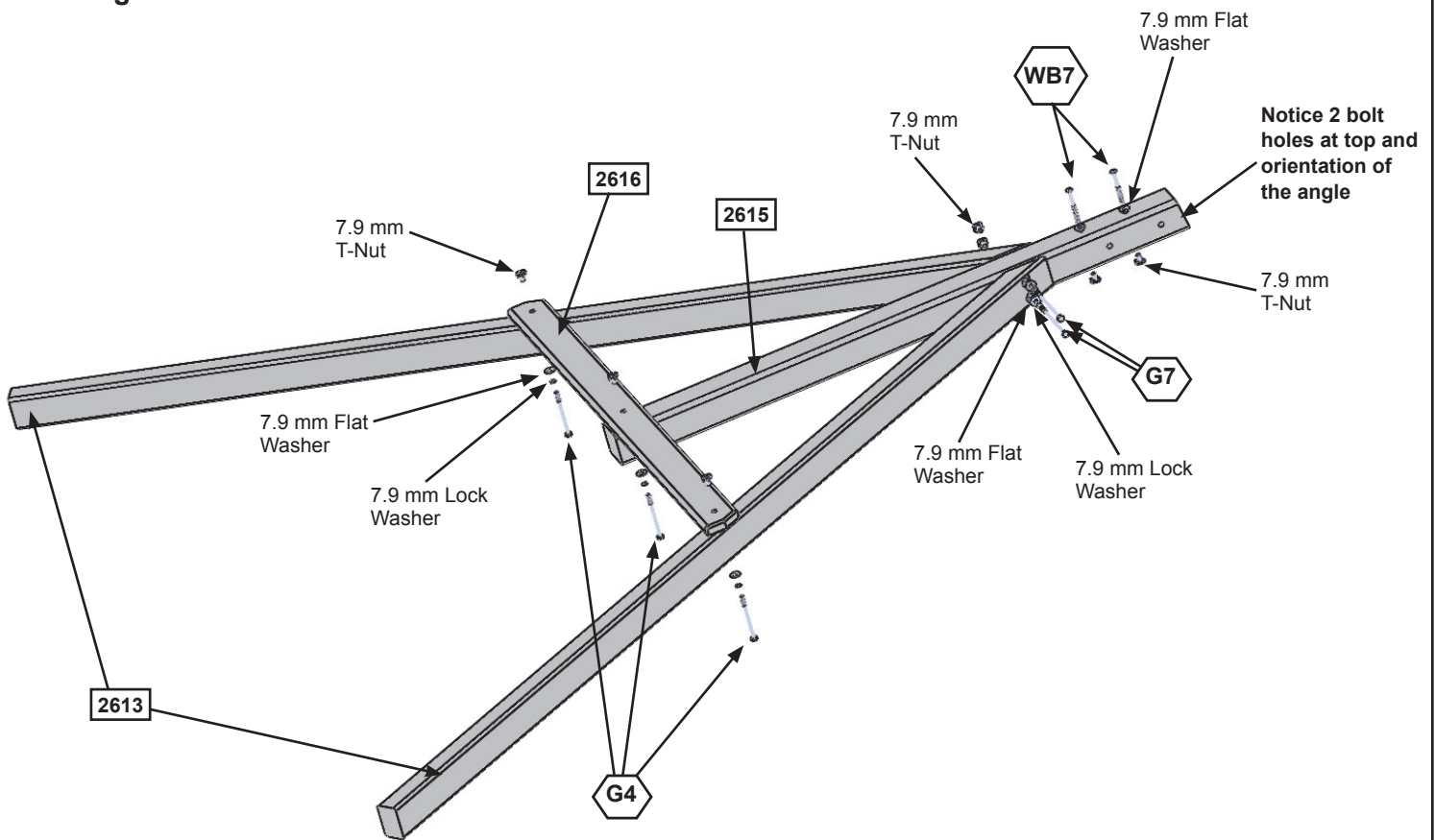

Note: Install T-nuts first!

Wood Parts

2 x Heavy SW Post 50.8 mm x 76.2 mm x 2201.9 mm
 1 x SW Upright 76.2 mm x 76.2 mm x 1294.3 mm
 1 x SW Support 23.8 mm x 82.6 mm x 1181.1 mm

Hardware

2 x 7.9 x 139.7mm Hex Bolt (7.9 mm lock washer, 7.9 mm flat washer, 7.9 mm t-nut)
 3 x 7.9 x 101.5mm Hex Bolt (7.9 mm lock washer, 7.9 mm flat washer, 7.9 mm t-nut)
 2 x 7.9 x 76.2mm Wafer Bolt (7.9 mm flat washer & 7.9 mm t-nut)

Step 7: Attach Swing End to Swing Beam

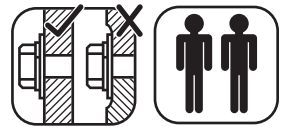

A: Place Swing End Assembly against Swing Beam Assembly then place 1 Beam Bracket on each side of the assembly (they are specific for left and right side) and attach with 5 (G21) Hex Bolts (with 2 flat washers and 1 lock nut). (fig. 7.1 and 7.2)

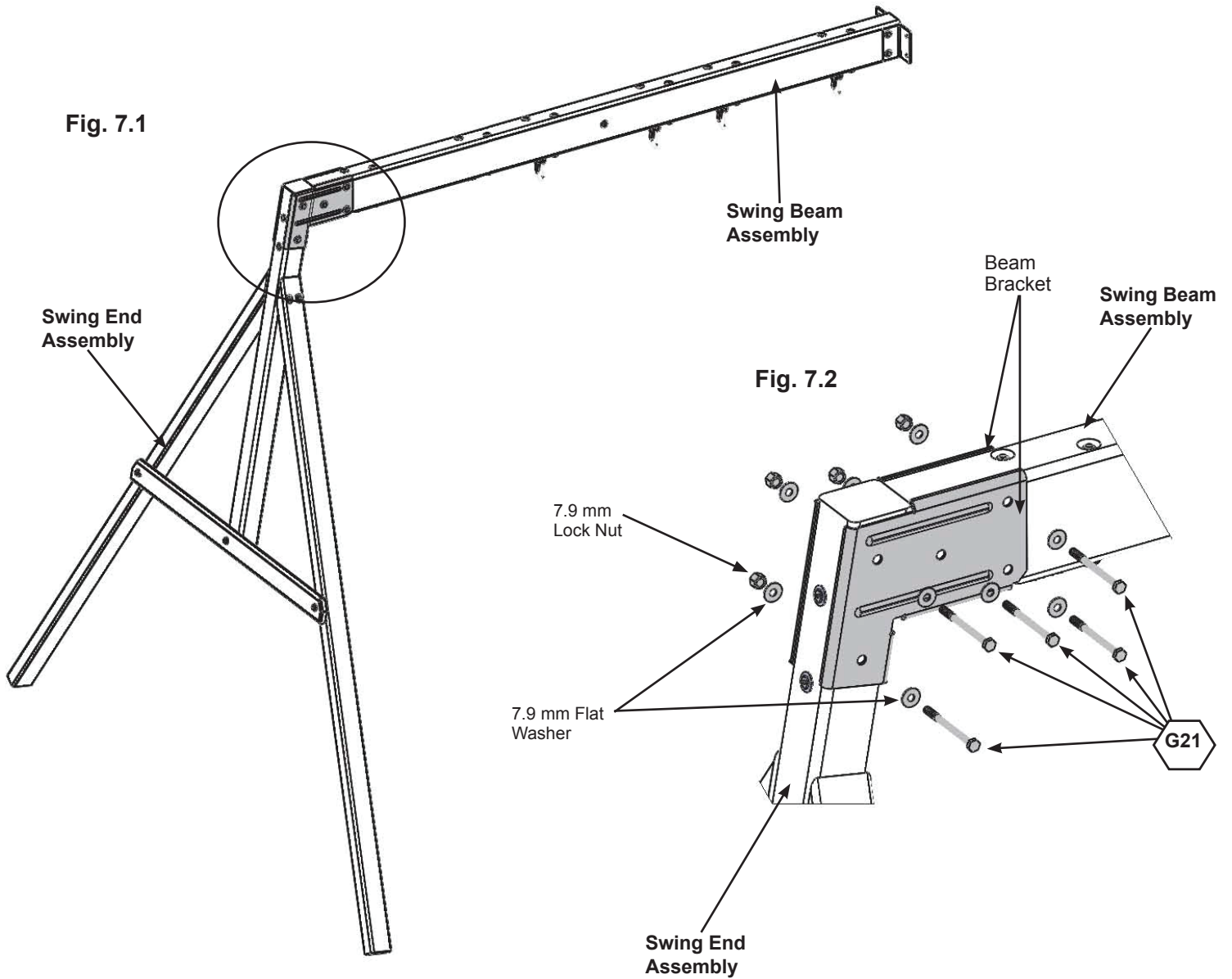

Hardware

5 x  7.9 x 95.2mm Hex Bolt
(7.9 mm flat washer x 2, 7.9 mm lock nut)

Other Parts

2 x Beam Bracket (Left/Right)

Step 8: Attach Swing Assembly To Fort



A: Place Swing Assembly against top of (2627) SW Wall Panel, make sure assembly is level then attach from inside the fort assembly into each L-Beam Bracket with 4 (G8) Hex Bolts (with 2 flat washers and 1 lock nut). (fig. 8.1)

Fig. 8.1

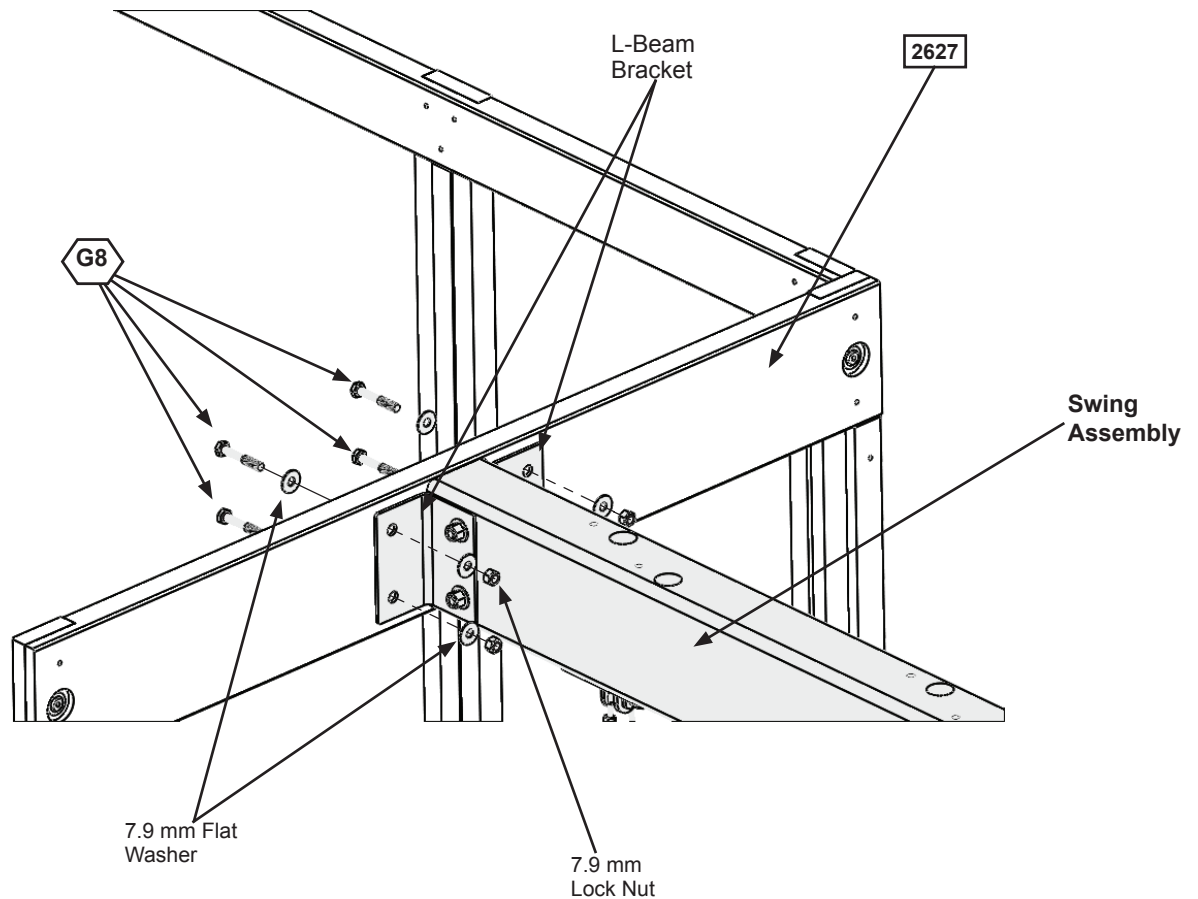

Hardware

4 x  7.9 x 50.8mm Hex Bolt
(7.9 mm flat washer x 2, 7.9 mm lock nut)

Step 9: Install Ground Stakes



MOVE FORT TO FINAL LOCATION PRIOR TO STAKING FINAL LOCATION MUST BE LEVEL GROUND

A: In the 5 places shown in fig. 9.1 drive the Rebar Ground Stakes 330 mm into the ground against outside front corner of (2622) End Panel Assembly, on both (2607) Diagonals and both (2613) Heavy SW Posts. Be careful not to hit the washer while hammering stakes into the ground as this could cause the washer to break off.

B: Attach ground stakes using 1 (S7) Pan Screw per ground stake (fig. 9.2 and 9.3).

C: After driving stakes into the ground, check for sharp edges caused by the impact of the hammer. Smooth any sharp edges from impact area and touch up with outdoor paint.

⚠ Warning! To prevent tipping and avoid potential injury, stakes must be driven 330 mm into ground. Digging or driving stakes can be dangerous if you do not check first for under-ground wiring, cables or gas lines.

Fig. 9.1

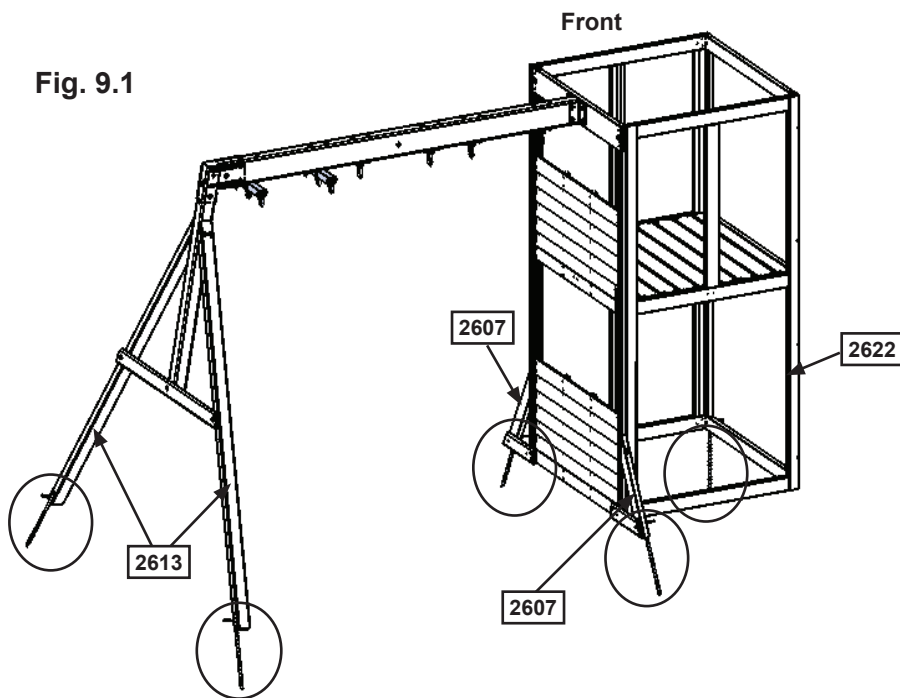

SEE FRONT COVER FOR
SAFETY CLEARANCE

Fig. 9.2

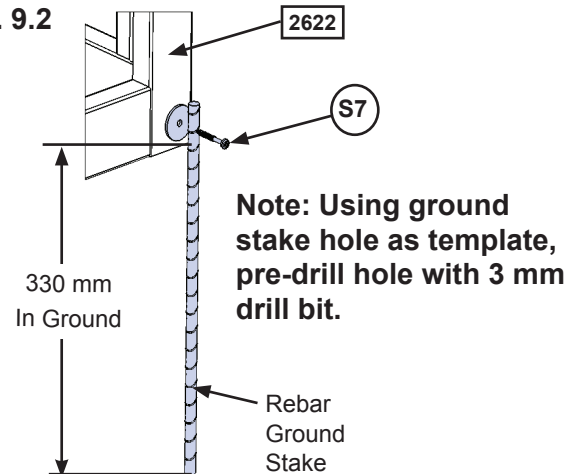
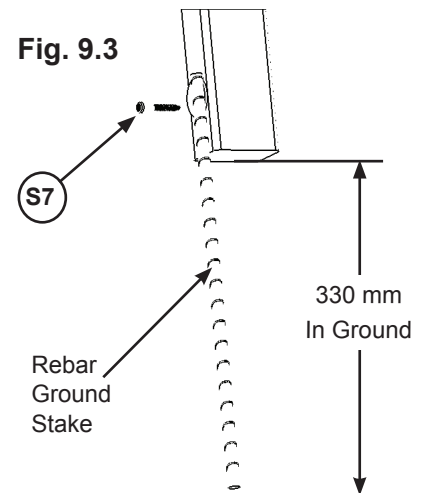

Fig. 9.3



Hardware

5 x (S7) #12 x 50.8mm Pan Screw

Other Parts

5 x Rebar Ground Stake

Step 10: Install Upper and Lower Jambs



A: In the upper opening of (2622) End Panel Assembly place 1 (2602) Upper Jamb so it measures 245 mm to the inside of the right post then attach with 2 Jamb Mounts using 4 (S0) Truss Screws per mount. (fig. 10.1, 10.3, 10.4 and 10.5)

B: In the lower opening of each (2618) Front Back Panel place 1 (2601) Lower Jamb so it measures 432 mm to the inside of each post then attach each (2601) Lower Jamb with 2 Jamb Mounts using 4 (S0) Truss Screws per mount. (fig. 10.2, 10.3, 10.4 and 10.5).

Fig. 10.1
Outside View

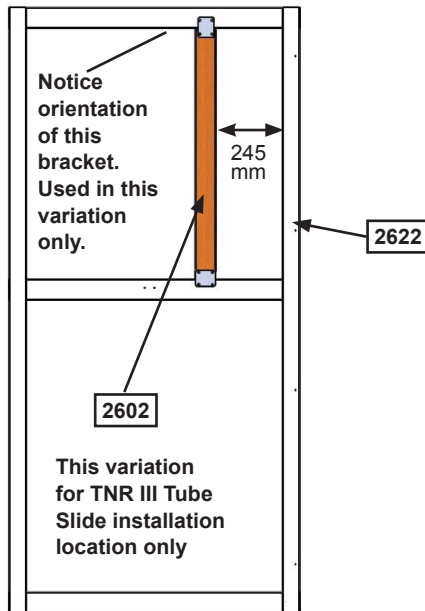

Fig. 10.2
Outside View

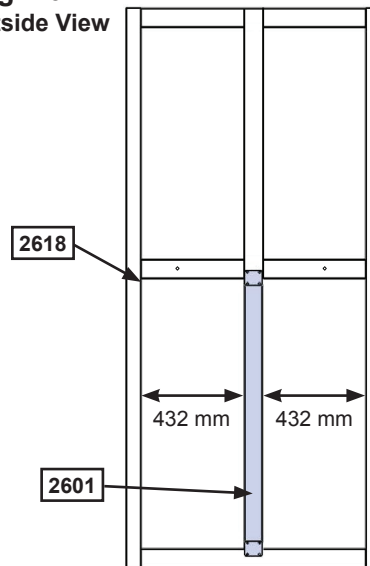
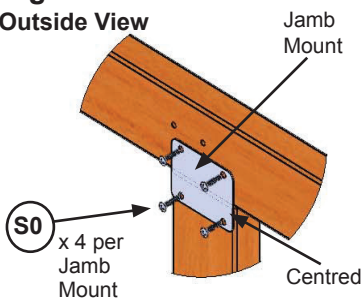

Fig. 10.3
Outside View



Note orientation:
Grooves to the inside.

Fig. 10.4

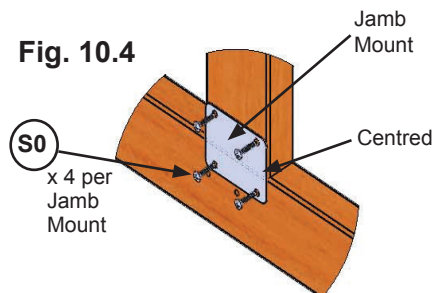
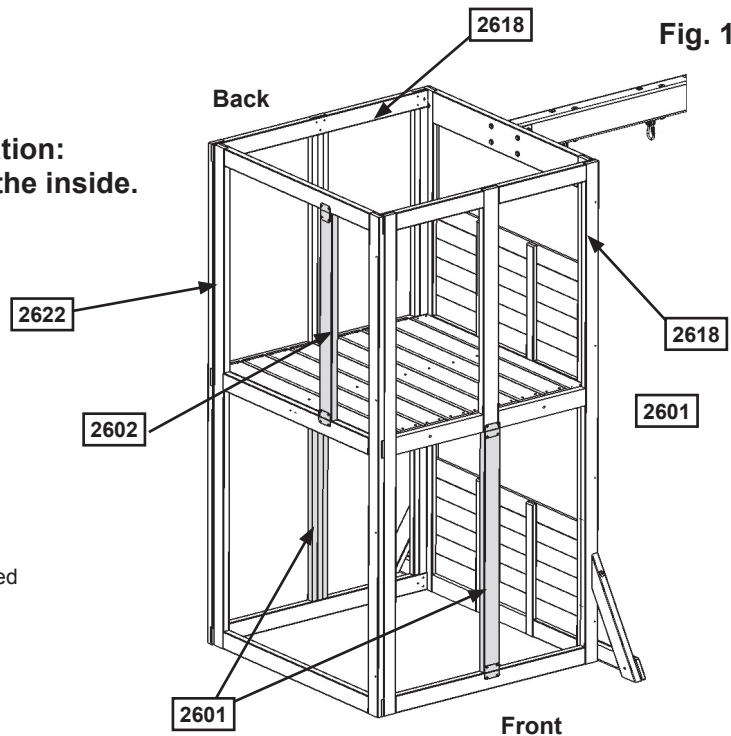

Fig. 10.5



Wood Parts

- 1 x 2602 Upper Jamb 31.8 mm x 76.2 mm x 912.8 mm
- 2 x 2601 Lower Jamb 31.8 mm x 76.2 mm x 1065.2 mm

Hardware

- 24 x S0 #8 x 22.2mm Truss Screw

Other Parts

- 6 x Jamb Mount

Step 11: Install Window and Wall Inserts

Part 1 - Front Wall

A: In the places shown in fig. 11.1 and 11.2, on the Front of the assembly install 2 (2655) Upper Window Inserts in the upper openings of (2618) Front Back Panel and 1 (2649) Lower Window Insert in the lower right opening of (2618) Front Back Panel using 9 (S0) Truss Screws per insert. (fig. 11.1, 11.2 and 11.3)

Fig. 11.1

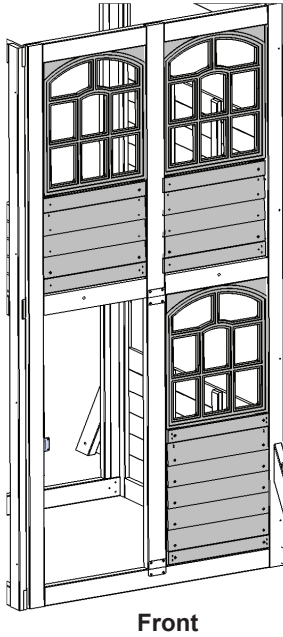

Fig. 11.2
Outside View

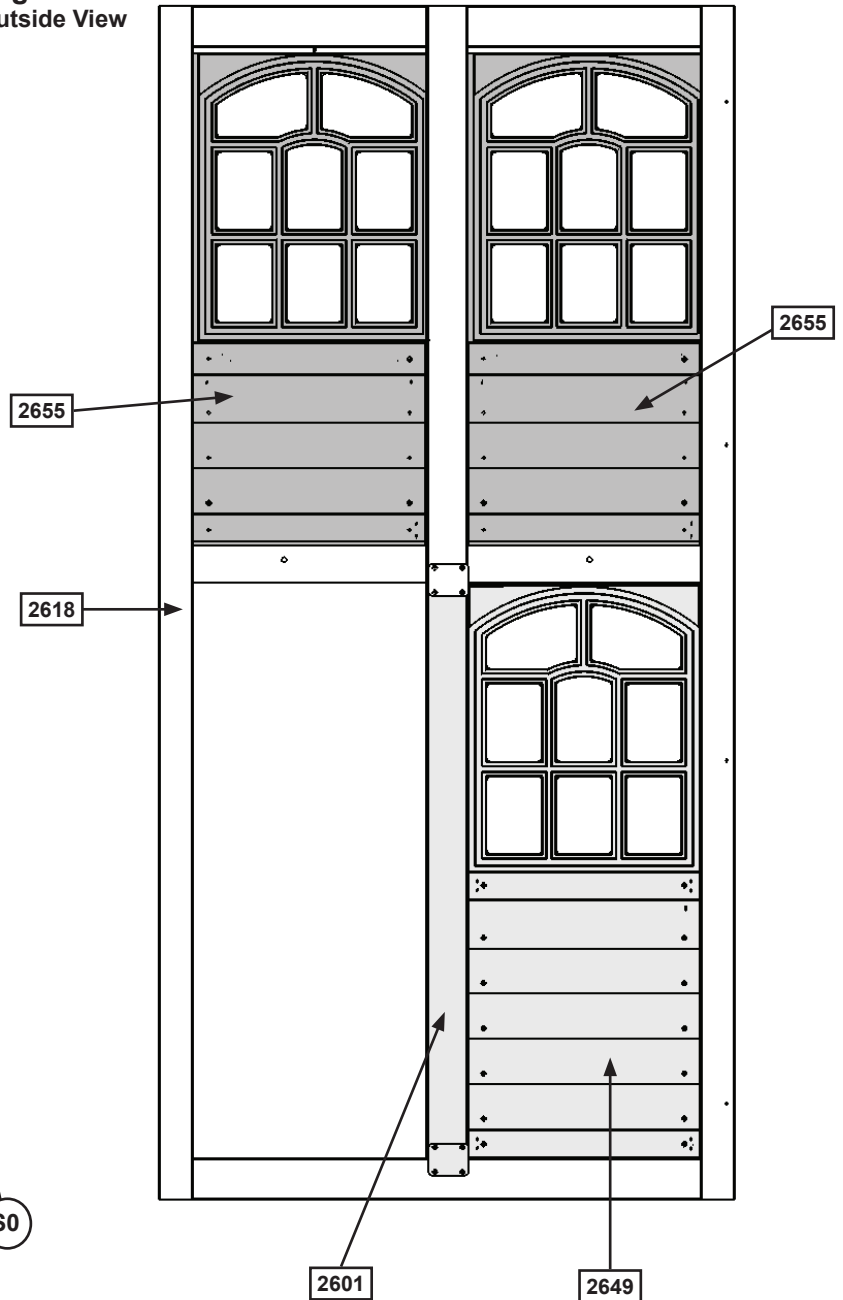
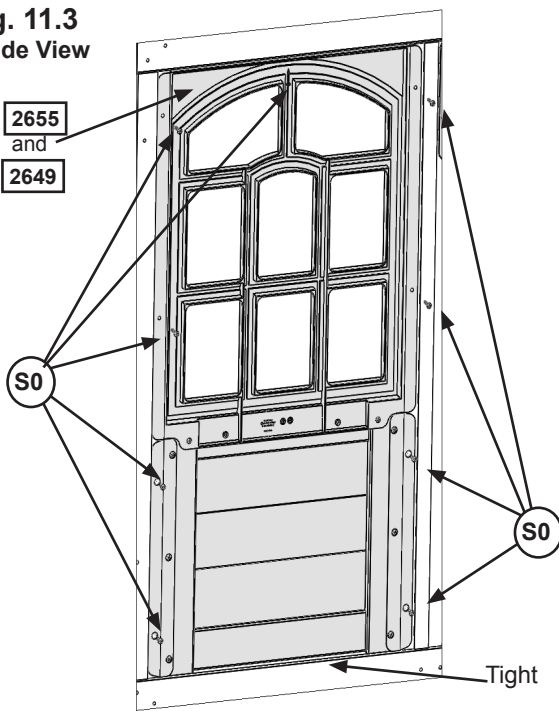

Fig. 11.3
Inside View



Wood Parts

- 2 x 2655 Upper Window Insert
- 1 x 2649 Lower Window Insert

Hardware

- 27 x S0 #8 x 22.2mm Truss Screw

Step 11: Install Window and Wall Inserts

Part 2 - Left Side

B: In the lower opening of (2622) End Panel Assembly install 1 (2665) Half Wall Insert using 4 (S0) Truss Screws. (fig. 11.4, 11.5 and 11.6)

C: In the upper openings of (2622) End Panel Assembly install 1 (8935) Lower SL Insert with 4 (S0) Truss Screws and 1 MOD Side Lite with 14 (S0) Truss Screws. (fig. 11.4, 11.5 and 11.7)

Fig. 11.4

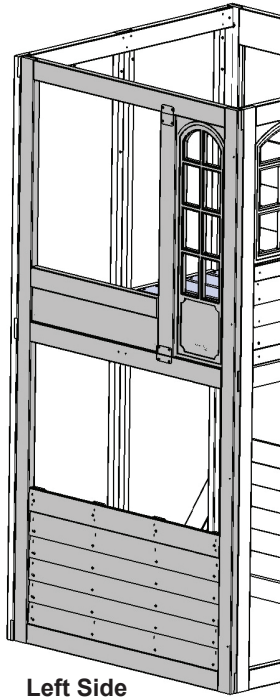

Left Side

Fig. 11.5
Outside View

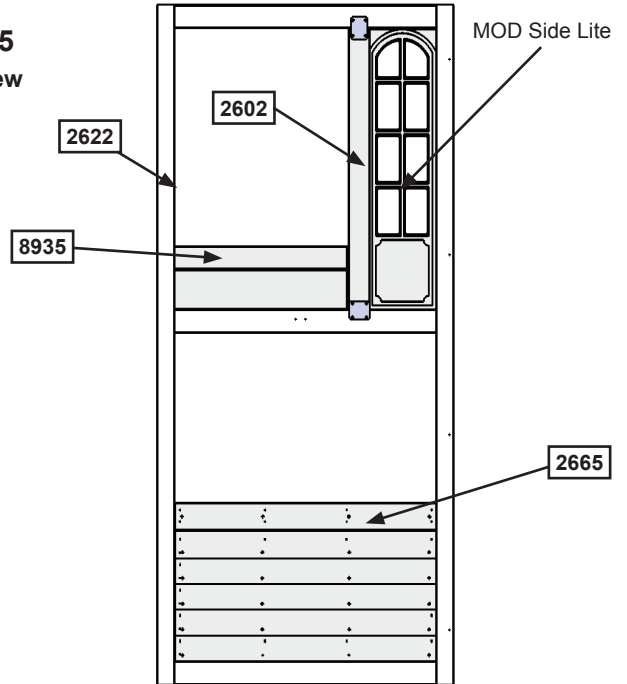

Fig. 11.7
Inside View

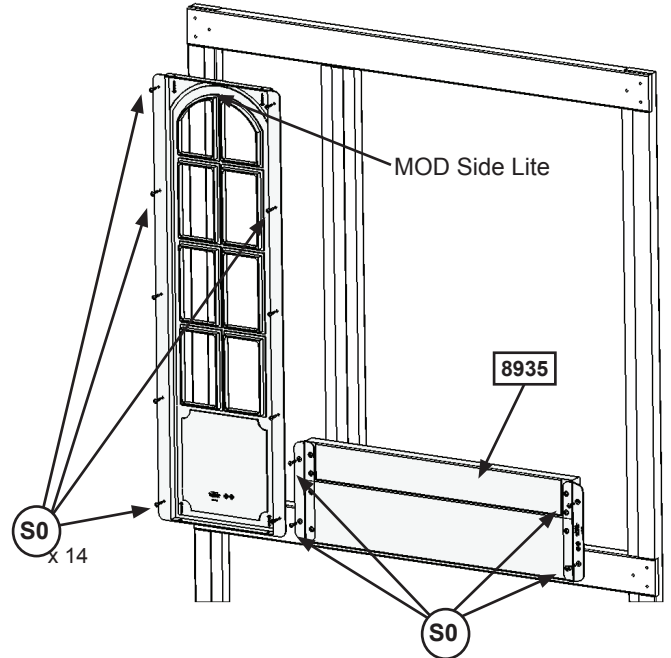
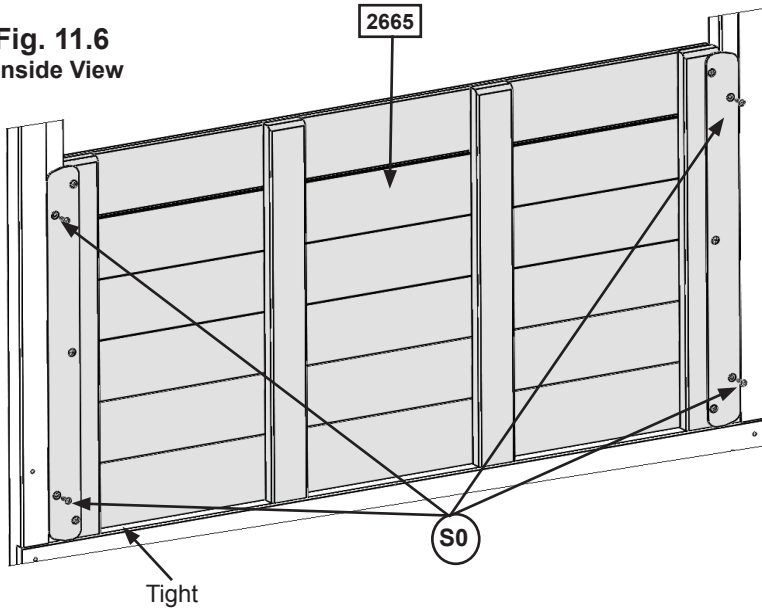

Fig. 11.6
Inside View



Wood Parts

- 1 x 2665 Half Wall Insert
- 1 x 8935 Lower SL Insert

Hardware

- 22 x S0 #8 x 22.2mm Truss Screw

Other Parts

- 1 x MOD Side Lite

Step 11: Install Window and Wall Inserts

Part 3 - Back Wall

D: In the lower openings of the back (2618) Front Back Panel install 1 (649A) Short Half Wall with 4 (S0) Truss Screws and 1 (2649) Lower Window Insert with 9 (S0) Truss Screws. (fig. 11.8, 11.9, 11.10 and 11.11)

E: In the upper openings of the back (2618) Front Back Panel install 1 (649A) Short Half Wall and 2 MOD 3-Pane Transoms with 4 (S0) Truss Screws per insert. (fig. 11.8, 11.9, 11.10 and 11.12)

Fig. 11.8



Fig. 11.9

Outside View

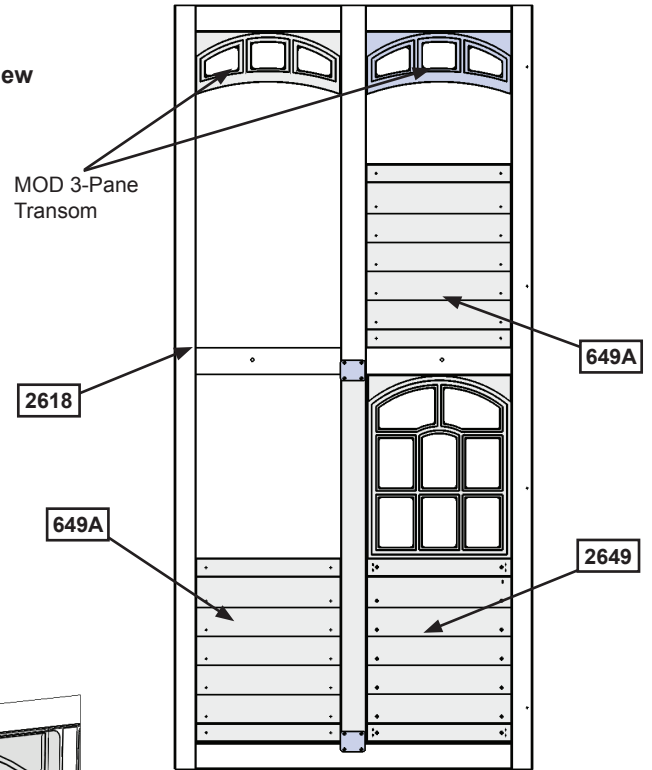

Fig. 11.11

Inside View

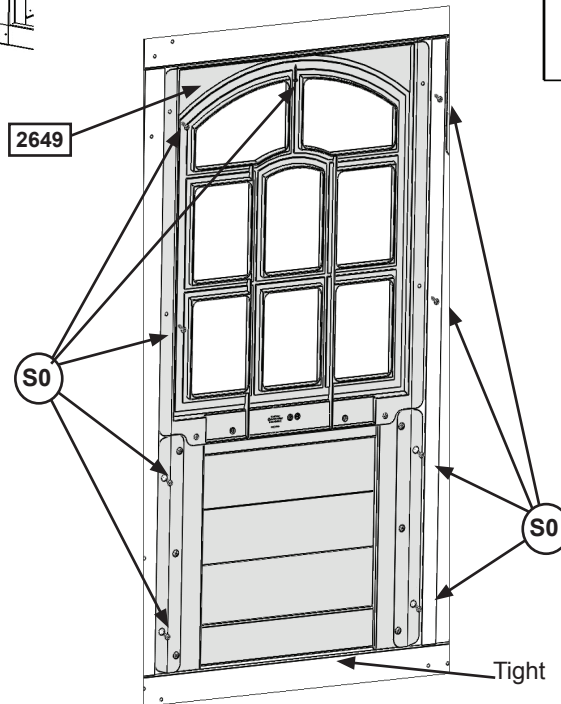

Fig. 11.10

Inside View

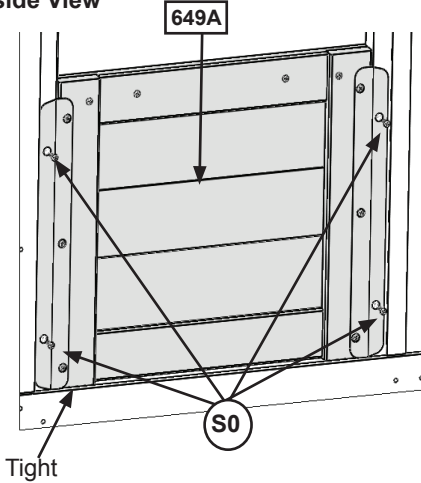
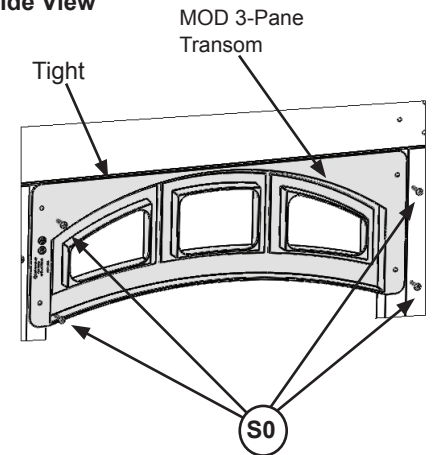

Fig. 11.12

Inside View



Wood Parts

- 1 x 2649 Lower Window Insert
- 2 x 649A Short Half Wall

Hardware

- 25 x S0 #8 x 22.2mm Truss Screw

Other Parts

- 2 x MOD 3-Pane Transom

Step 12: Clock Assembly



A: From the back of the Base Clock insert the Clock Adapter then from the front of the Base Clock place the Hour Hand over the Clock Adapter making sure they line up properly. Press the Minute Hand over the Hour Hand and connect with the Clock Screw. (fig. 12.1)

B: On the Front of the Assembly place Clock Assembly centred under window of (2649) Lower Window Insert then with a helper attach through insert and into each (2717) Clock Block with 4 (S2) Wood Screw, 2 per block. (fig. 12.2, 12.3 and 12.4)

Do not over tighten screws.

Fig. 12.1
Side View

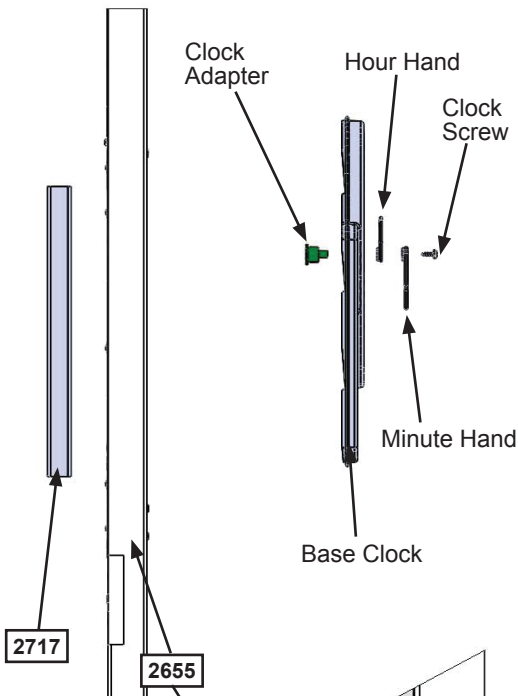
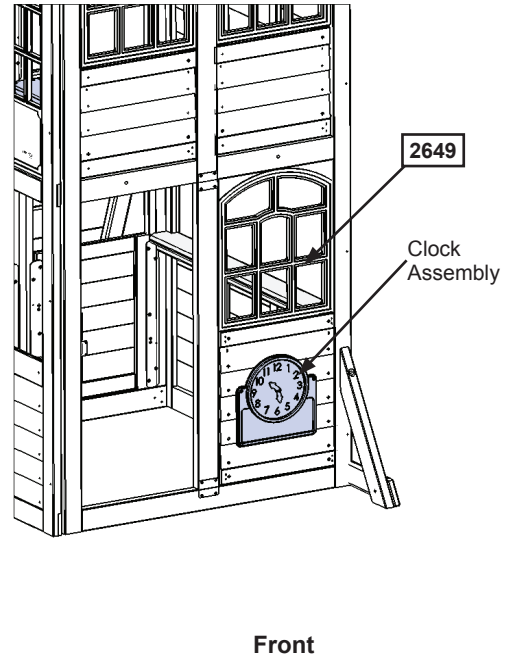

Fig. 12.2



Front

Fig. 12.3
Outside View

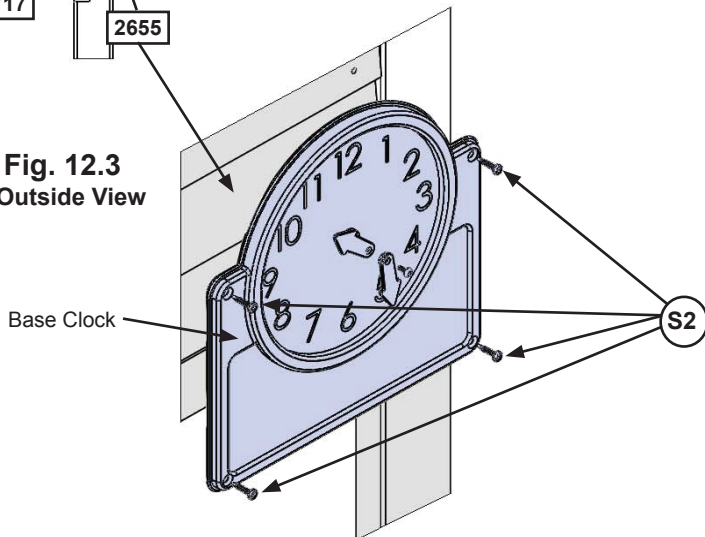
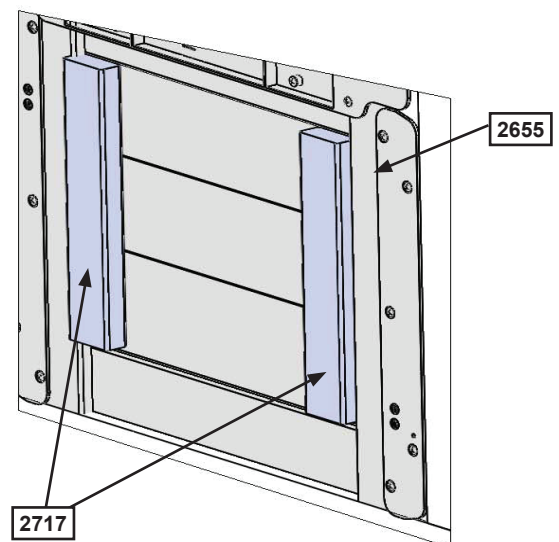

Fig. 12.4
Inside View



Wood Parts

2 x 2717 Clock Block 19.1 mm x 44.5 mm x 247.7 mm

Hardware

4 x S2 #8 x 38.1mm Wood Screw

Other Parts

1 x Base Clock
1 x Clock Subset
1 x Clock Adapter
1 x Hour Hand
1 x Minute Hand
1 x Clock Screw

Step 13: Rock Wall Assembly



Fig. 13.1

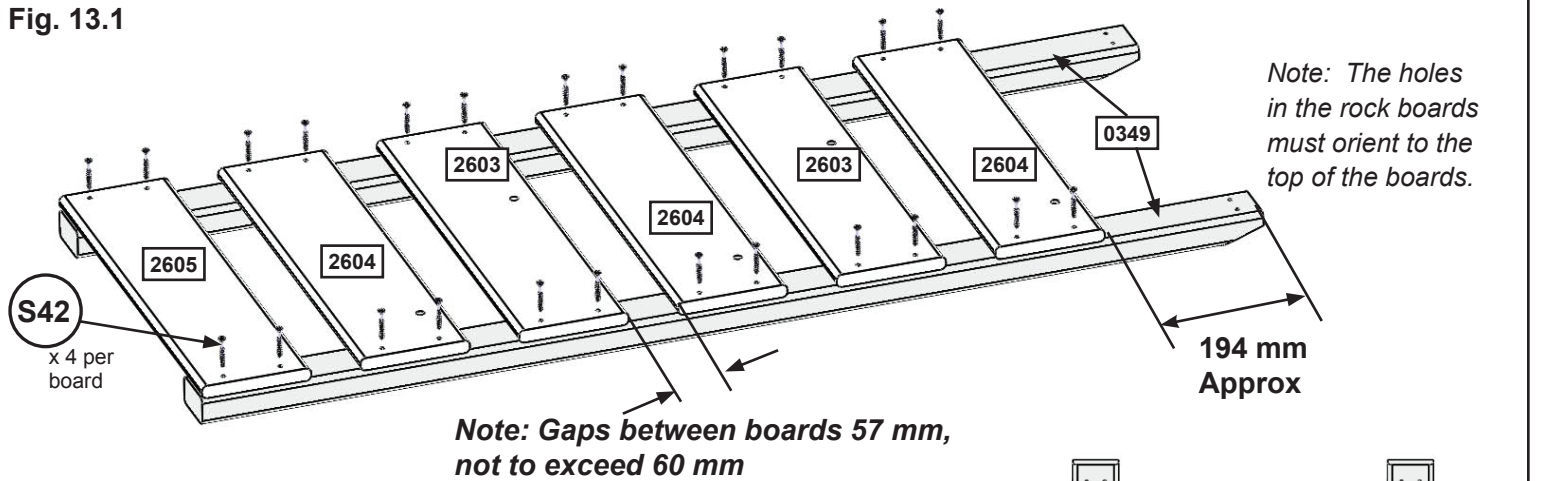

Note: Gaps between boards 57 mm, not to exceed 60 mm

Note: The holes in the rock boards must orient to the top of the boards.

Pre-drill each hole using a 1/8" drill bit for S42

A: Lay 2 (0349) Rock Rails down, side by side with angled edges facing down. (fig. 13.1)

B: Place (2605) Access Board on the bottom of each (0349) Rock Rail as shown in fig. 13.1. Make sure (2605) Access Board is flush to the outside and bottom edges of each (0349). Attach using 4 (S42) Pan Screws.

C: 194 mm down from the top of both (0349) Rock Rails place 1 (2604) Rock Board B, making sure the sides are flush to the outside edges of each (0349) Rock Rail. Attach using 4 (S42) Pan Screws. (fig. 13.1)

D: In between the (2605) Access Board and (2604) Rock Board B stagger 2 (2604) Rock Board Bs and 2 (2603) Rock Board As using 4 (S42) Pan Screws per board. Placing them as shown in fig. 13.1, this will prevent rocks from forming a straight line. Make sure the boards are evenly spaced and do not exceed 60 mm between boards.

Fig. 13.2

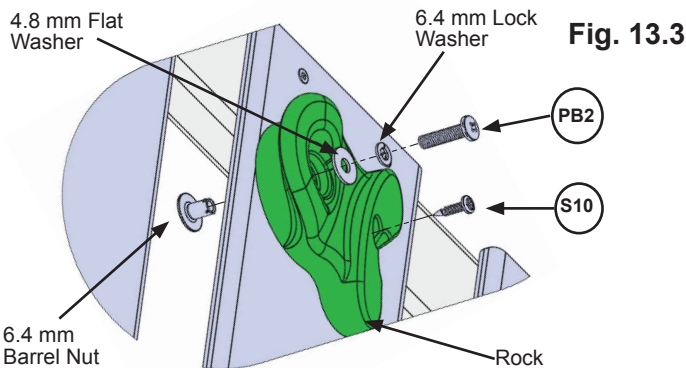
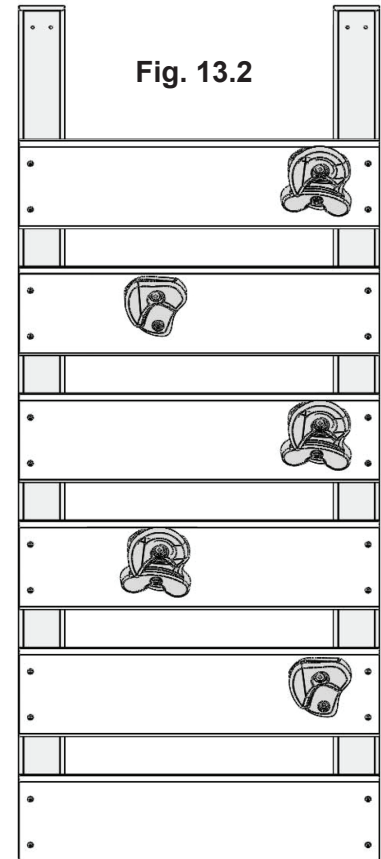

E: Place 1 rock on each (2603) Rock Board A and (2604) Rock Board B (fig. 13.2) and attach using 1 (PB2) Pan Bolt (with lock washer, flat washer and barrel nut) and 1 (S10) Pan Screw per rock. The Screw must be in the hole directly under the Pan Bolt, it will stop the rock from spinning. (fig. 13.3)

Wood Parts

- 1 x 2605 Access Board 15.9 mm x 133.4 mm x 501.7 mm
- 3 x 2604 Rock Board B 15.9 mm x 133.4 mm x 501.7 mm
- 2 x 2603 Rock Board A 15.9 mm x 133.4 mm x 501.7 mm
- 2 x 0349 Rock Rail 34.9 mm x 63.5 mm x 1295.4 mm

Hardware

- 24 x S42 #12 x 38.1mm Pan Screw
- 5 x S10 #8 x 25.4mm Pan Screw
- 5 x PB2 6.4 x 31.8mm Pan Bolt (6.4 mm lock washer, 4.8 mm flat washer & 6.4 mm barrel nut)

Other Parts

- 5 x Rocks (2 green/3 yellow)

Step 14: Attach Rock Wall Assembly to Fort Part 1

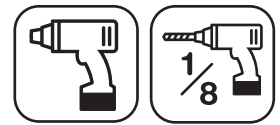

A: On the Back of the assembly place Rock Wall Assembly centred in (2618) Front Back Panel opening and flush as shown in fig. 14.1 and 14.2. Attach (0349) Rock Rails to the panel using 4 (S11) Wood Screws. (fig. 14.2 and 14.3)

B: Attach 1 (2605) Access Board to top of Rock Wall Assembly, flush to top of (0349) Rock Rail using 4 (S42) Pan Screws. (fig. 14.4)

Pre-drill each hole using a 1/8" drill bit for S42

Fig. 14.1

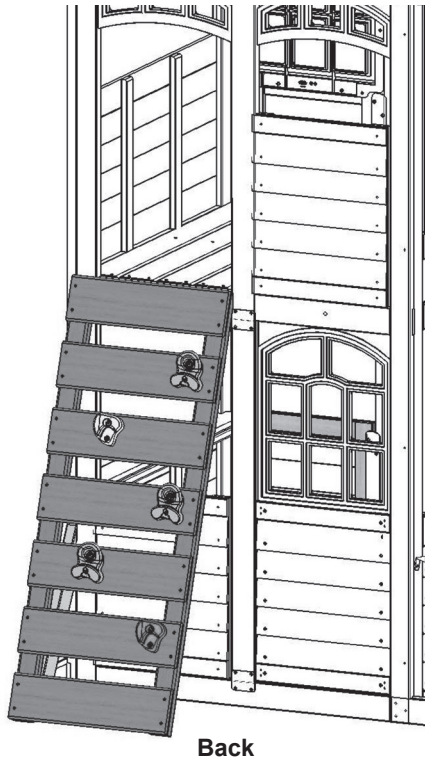

Fig. 14.3

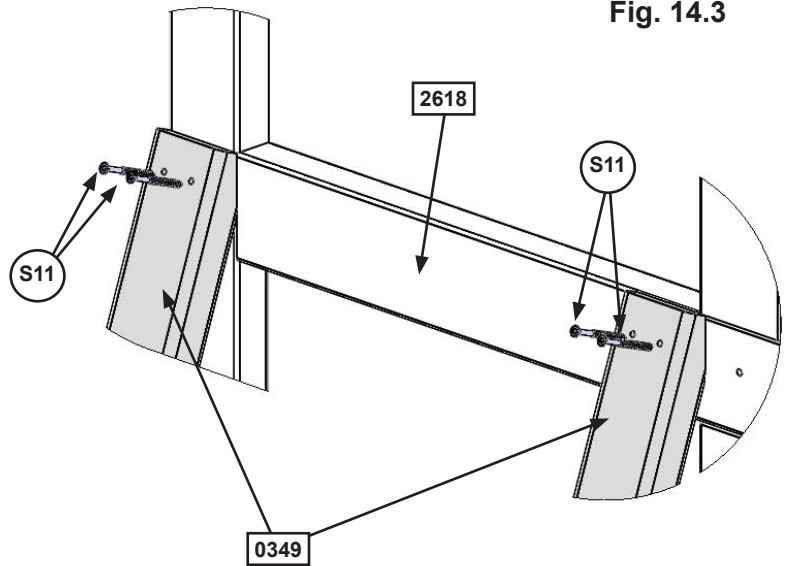

Fig. 14.2

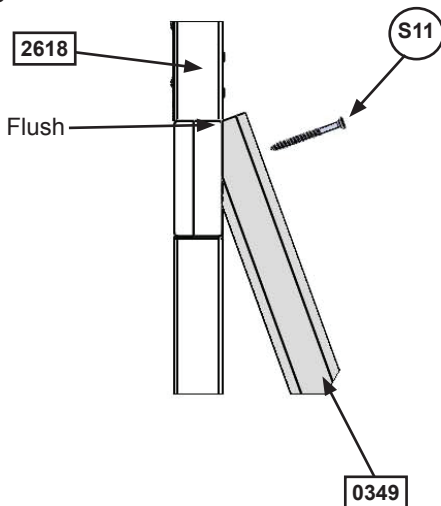
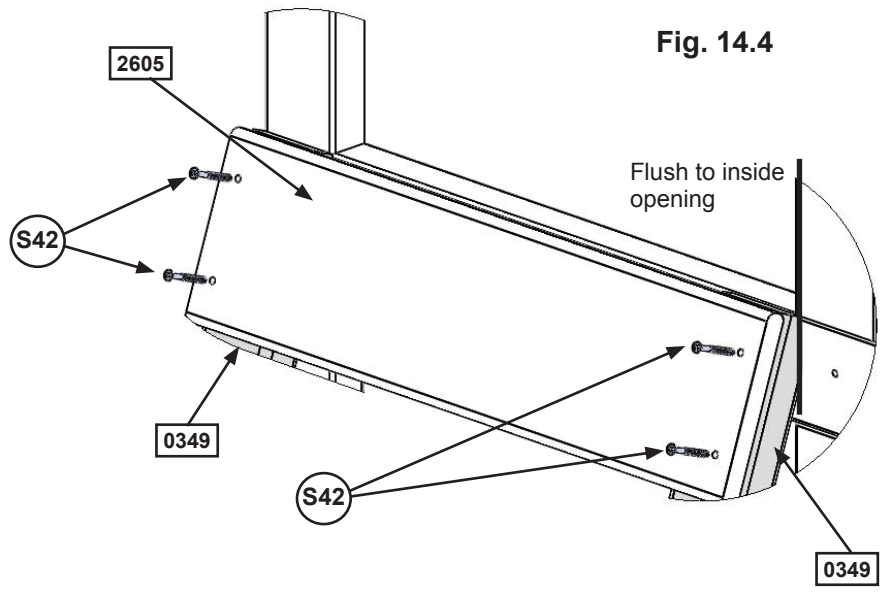

Fig. 14.4



Wood Parts

1 x [2605] Access Board 15.9 mm x 133.4 mm x 501.7 mm

Hardware

4 x [S42] #12 x 38.1mm Pan Screw

4 x [S11] #8 x 50.8mm Wood Screw

Step 14: Attach Rock Wall Assembly to Fort

Part 2



C: Drive 1 Rebar Ground Stake 330 mm into the ground against outside (0349) Rock Rail then attach with 1 (S7) Pan Screw. Be careful not to hit the washer while hammering stake into the ground as this could cause the washer to break off. (fig. 14.5 and 14.6)

D: After driving stake into the ground, check for sharp edges caused by the impact of the hammer. Smooth any sharp edges from impact area and touch up with outdoor paint.

⚠Warning! To prevent tipping and avoid potential injury, stakes must be driven 330 mm into ground. Digging or driving stakes can be dangerous if you do not check first for under-ground wiring, cables or gas lines.

Fig. 14.5

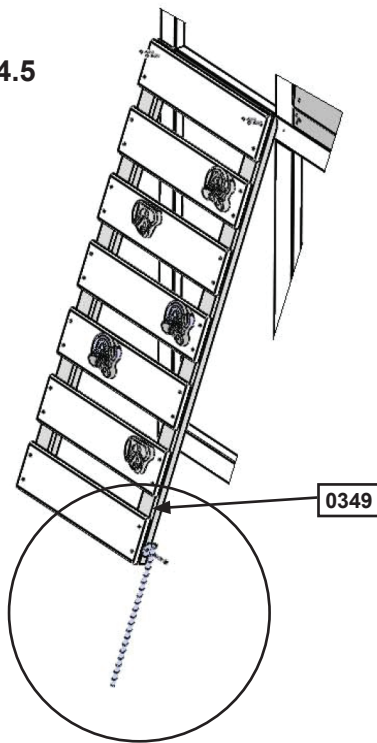
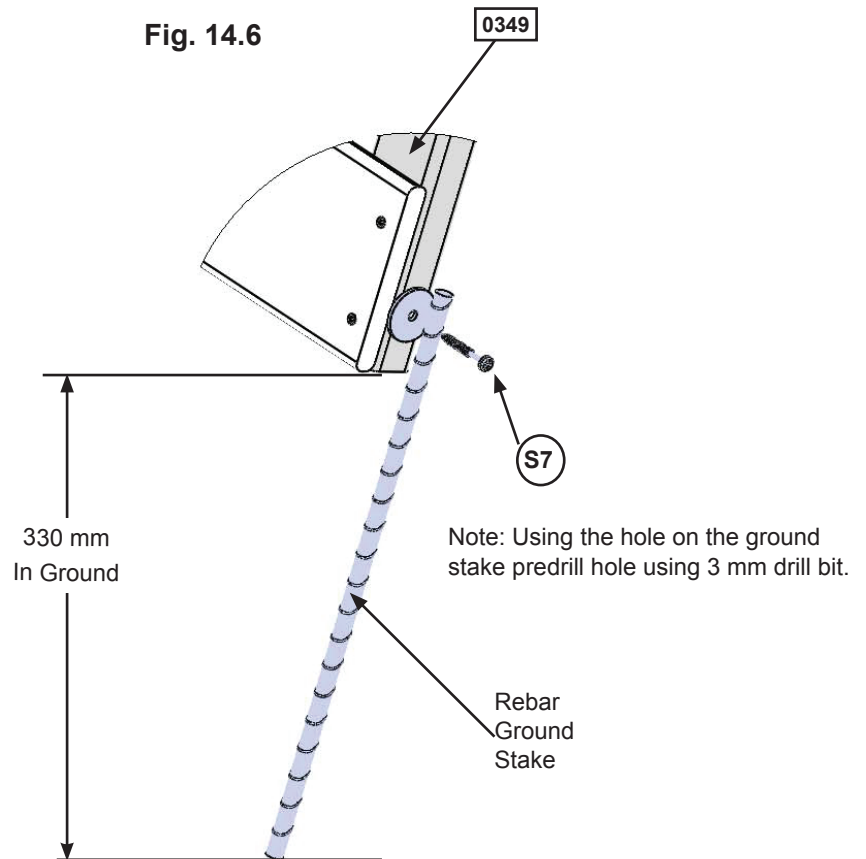

Fig. 14.6



Hardware

1 x  #12 x 50.8mm Pan Screw

Other Parts

1 x Rebar Ground Stake

Step 15: Cafe Table Assembly

A: Place (2612) Table Support flush to the notched out ends of (2611) Table Top and attach with 4 (S7) Pan Screws as shown in fig. 15.1.

B: Place Table Top Assembly from the inside of the assembly tight in the opening (2627) SW Wall Panel then attach (2612) Table Support to the panel with 2 (S3) Wood Screws. (fig. 15.2)

Fig. 15.1

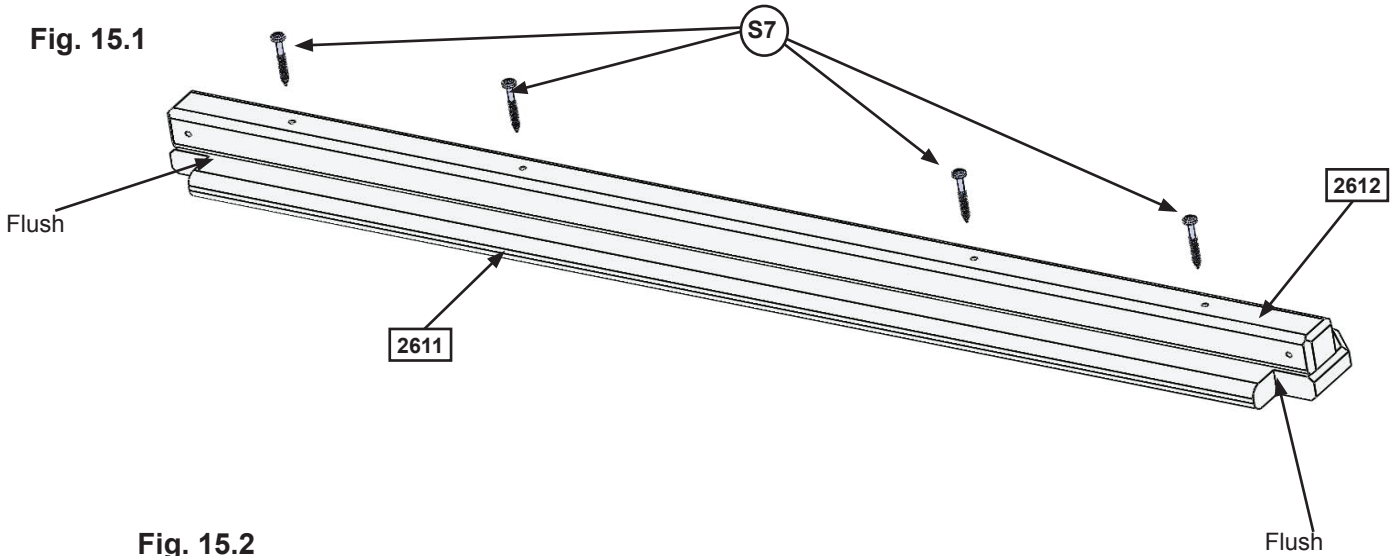
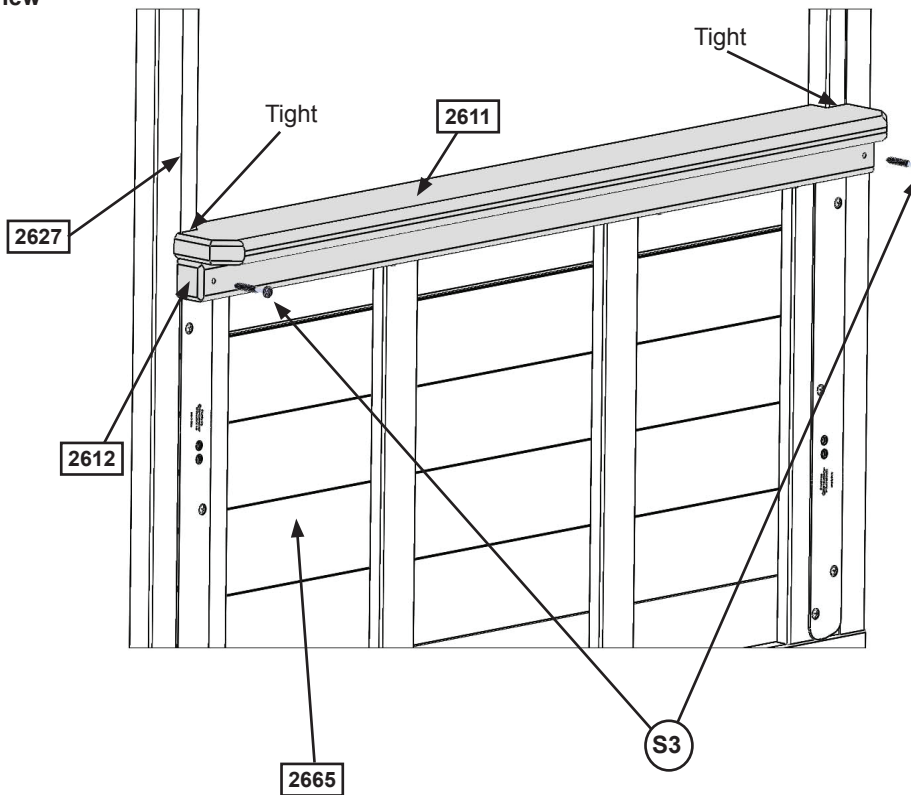

Fig. 15.2
Inside View



Wood Parts

- 1 x 2612 Table Support 38.1 mm x 38.1 mm x 1006.5 mm
- 1 x 2611 Table Top 23.8 mm x 108 mm x 1006.5 mm

Hardware

- 4 x S7 #12 x 50.8mm Pan Screw
- 2 x S3 #8 x 63.5mm Wood Screw

Step 16: Attach Cafe Canopy to Fort



A: Feed Cafe Canopy Frame through the pocket of the Cafe Canopy. (fig. 16.1)

B: With a helper hold the Canopy against the fort, centred on (2618) Front Back Panel (fig. 16.2), make sure the Cafe Canopy is smooth and tight then attach to the panel with 1 (S5) Pan Screw (with #8 flat washer), measure 38 mm down from the first screw then attach a second screw and washer. Follow measurements as shown in fig. 16.3 for remaining screws and washers. Measurements must be exact.

C: Hold the Cafe Canopy Frame against the panel and attach with 1 (S6) Pan Screw per side. (fig. 16.3)

Fig. 16.1

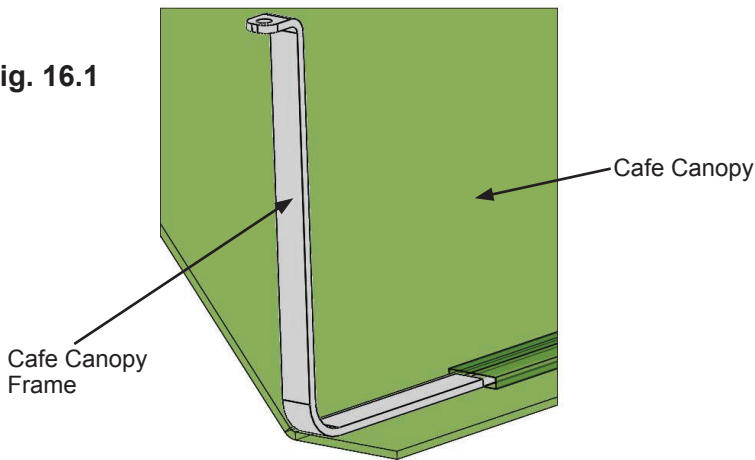

Fig. 16.2

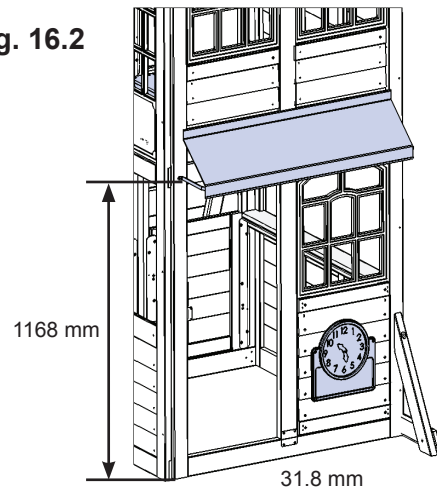
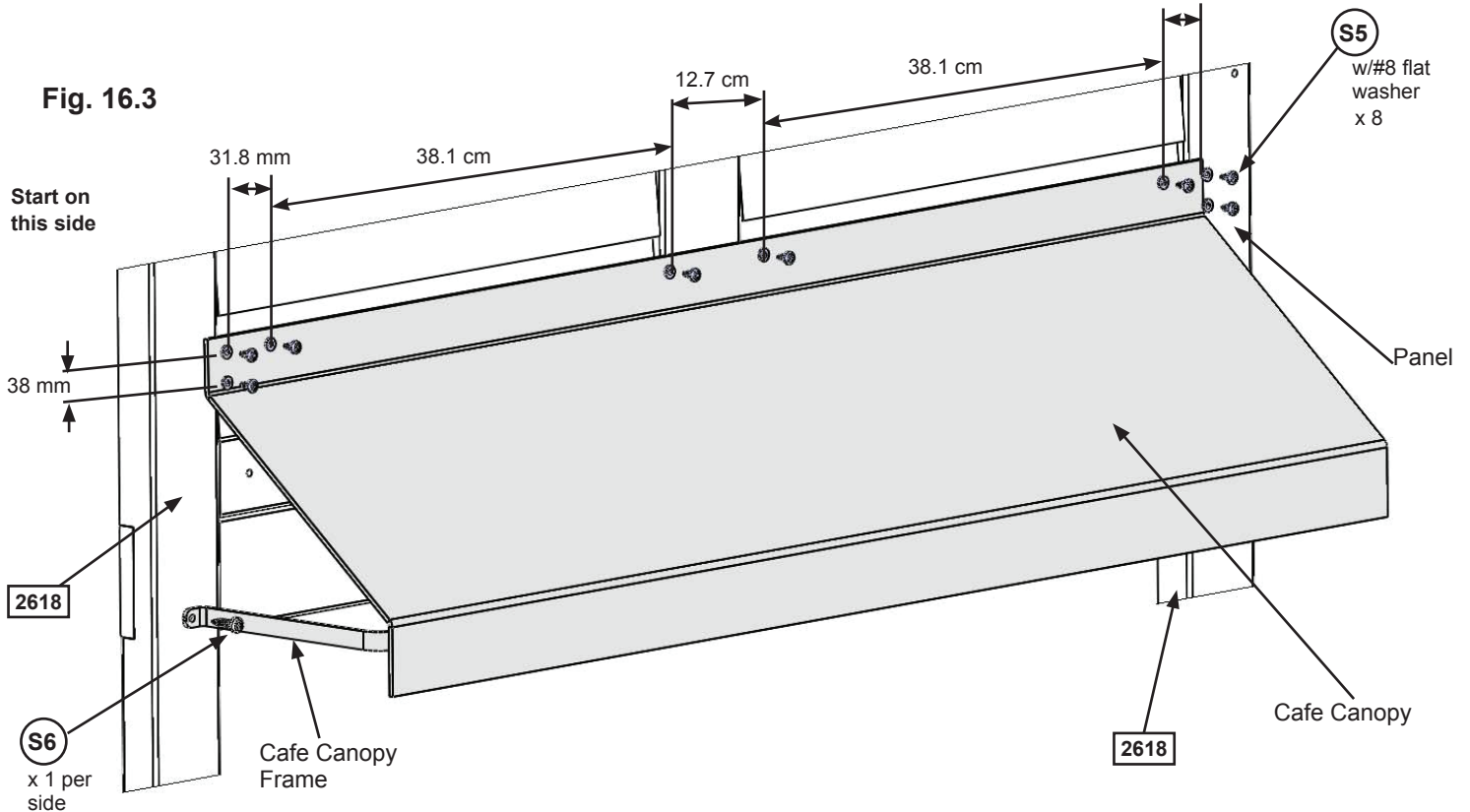

Fig. 16.3



Hardware

- 8 x S5 #8 x 12.7mm Pan Screw (#8 flat washer)
- 2 x S6 #12 x 25.4mm Pan Screw

Other Parts

- 1 x Cafe Canopy Frame
- 1 x Cafe Canopy

Step 17: Attach Door Components Part 1



A: On the inside of (2709) Door Window Panel measure 38 cm up from the bottom and attach Catch Plate flush to the edge using 2 (S18) Wood Screws. (fig. 17.1)

B: On the inside of (2709) Door Window Panel measure 56 cm up from the bottom and attach 1 Door Handle using 2 (S13) Pan Screws. (fig. 17.1)

Fig. 17.1

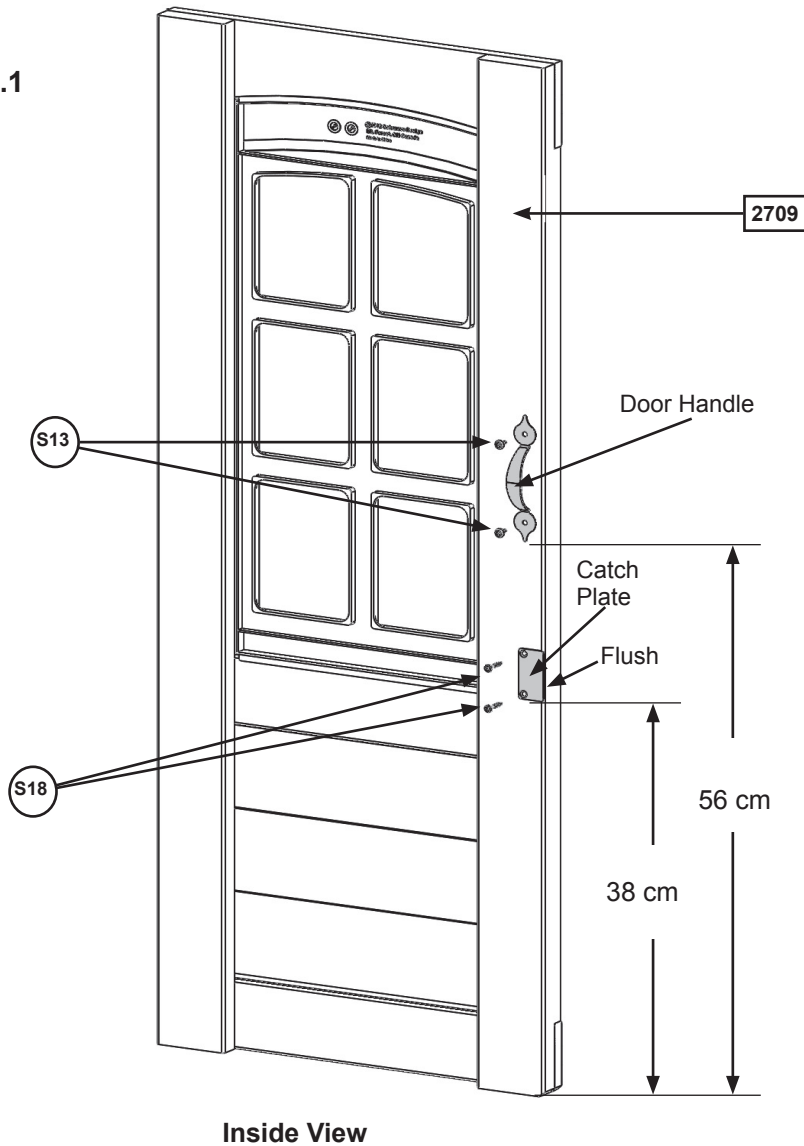

Inside View

Wood Parts

1 x 2709 Door Window Panel 31.8 mm x 400.1 mm x 1035.1 mm

Hardware

2 x S18 #6 x 25.4mm Wood Screw
2 x S13 #6 x 16mm Pan Screw

Other Parts

1 x Door Handle
1 x Catch Plate

Step 17: Attach Door Components Part 2

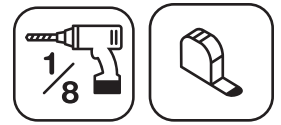

C: On the outside of the (2709) Door Window Panel attach the second Door Handle at approximately the same place as the one on the inside. Use 2 (S13) Pan Screws. (fig. 17.2)

D: On the opposite side of the Door Handle measure 15.9 mm from the top and bottom of (2709) Door Window Panel attach 2 Door Hinges on the outside using 3 (S13) Pan Screws per Hinge. (fig. 17.2 and 17.4)

Note: Hinge stops must be tight to (2709) Door Window Panel. (fig. 17.3)

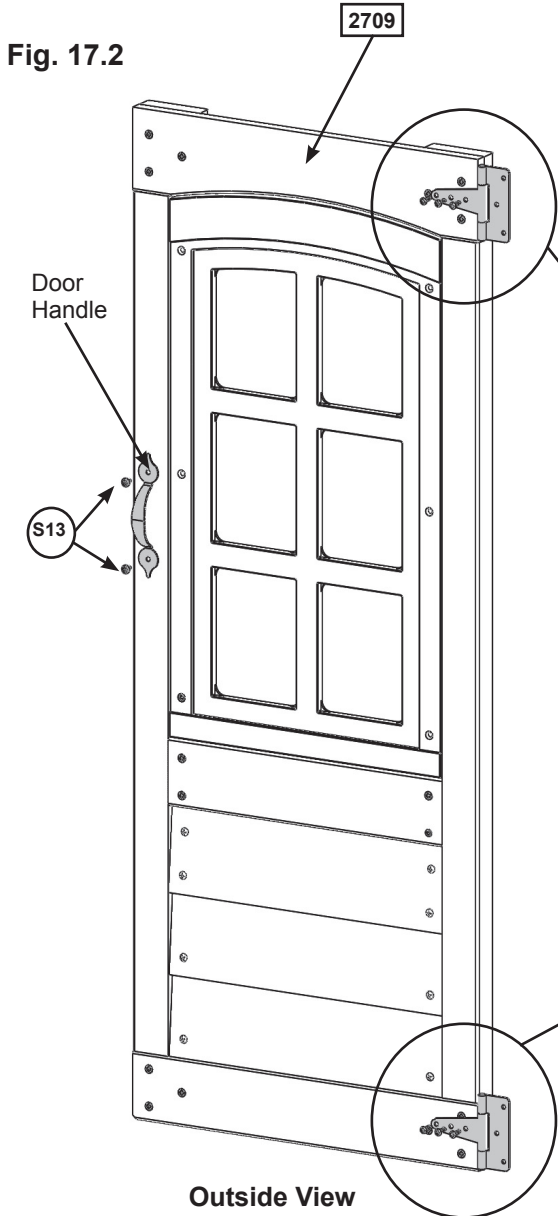

Fig. 17.3
Top View

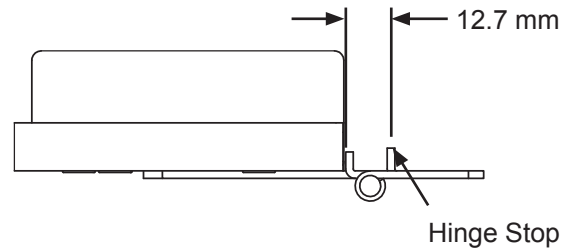
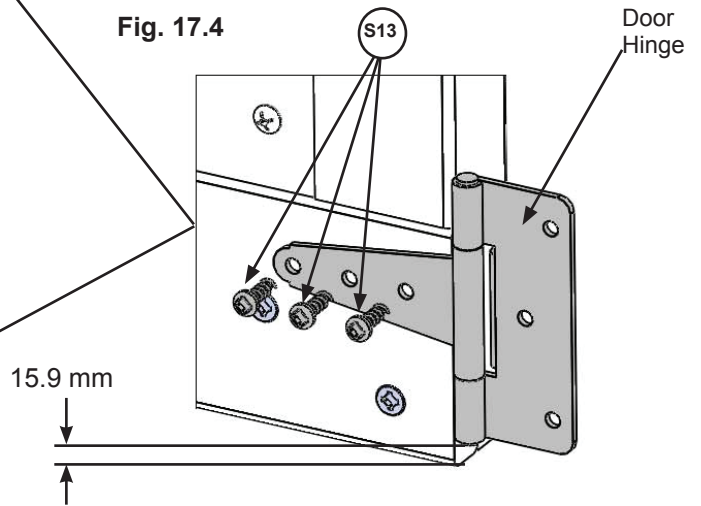

Fig. 17.4



Note: Predrill holes using a 3 mm drill bit.

Hardware
8 x #6 x 16mm Pan Screw

Other Parts
1 x Door Handle
2 x Door Hinge

Step 18: Attach Door Assembly to Fort



A: On the Front of the fort in the opening of (2618) Front Back Panel, measure 15.9 mm up from the bottom of the opening and maximum 15.9 mm from the inside edge of (2601) Lower Jamb and attach the remaining side of the hinges using 3 (S13) Pan Screws per hinge. (fig. 18.1, 18.2 and 18.3)

Fig. 18.1

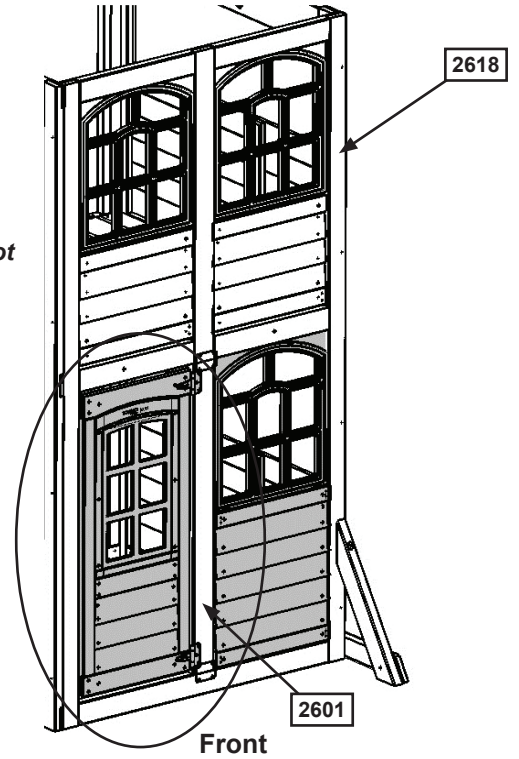

Fig. 18.2
Outside View

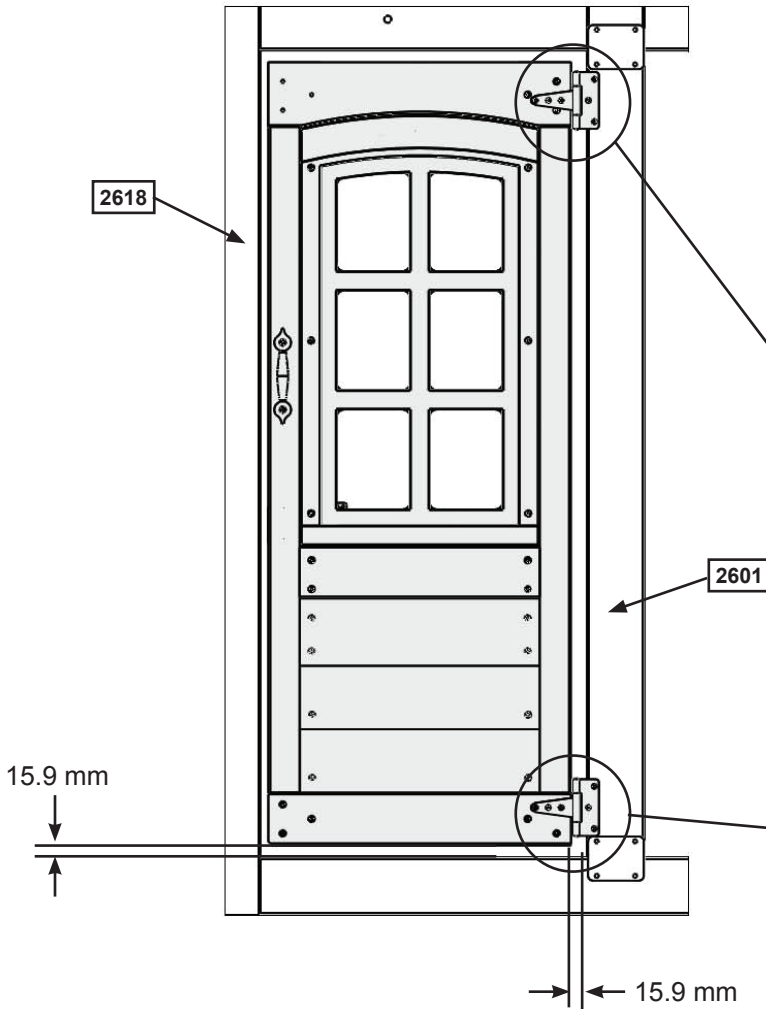
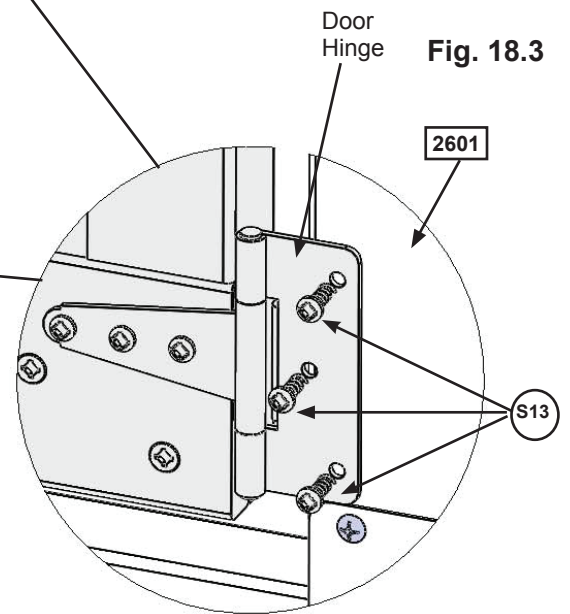

Fig. 18.3



Hardware

6 x (S13) #6 x 16mm Pan Screw

Step 19: Attach Door Stop



A: In the notched out opening of (2715) Door Stop attach the Magnetic Catch using 2 (S18) Wood Screws. (fig. 19.1) **Important: Use a handheld screwdriver and DO NOT over tighten.**

B: On the inside of the assembly, attach (2715) Door Stop to (2618) Front Back Panel with 3 (S11) Wood Screws, making sure (2715) Door Stop overhangs the panel by 32 mm and is in position to receive the Catch Plate. (fig. 19.2 and 19.3).

Fig. 19.2
Inside View

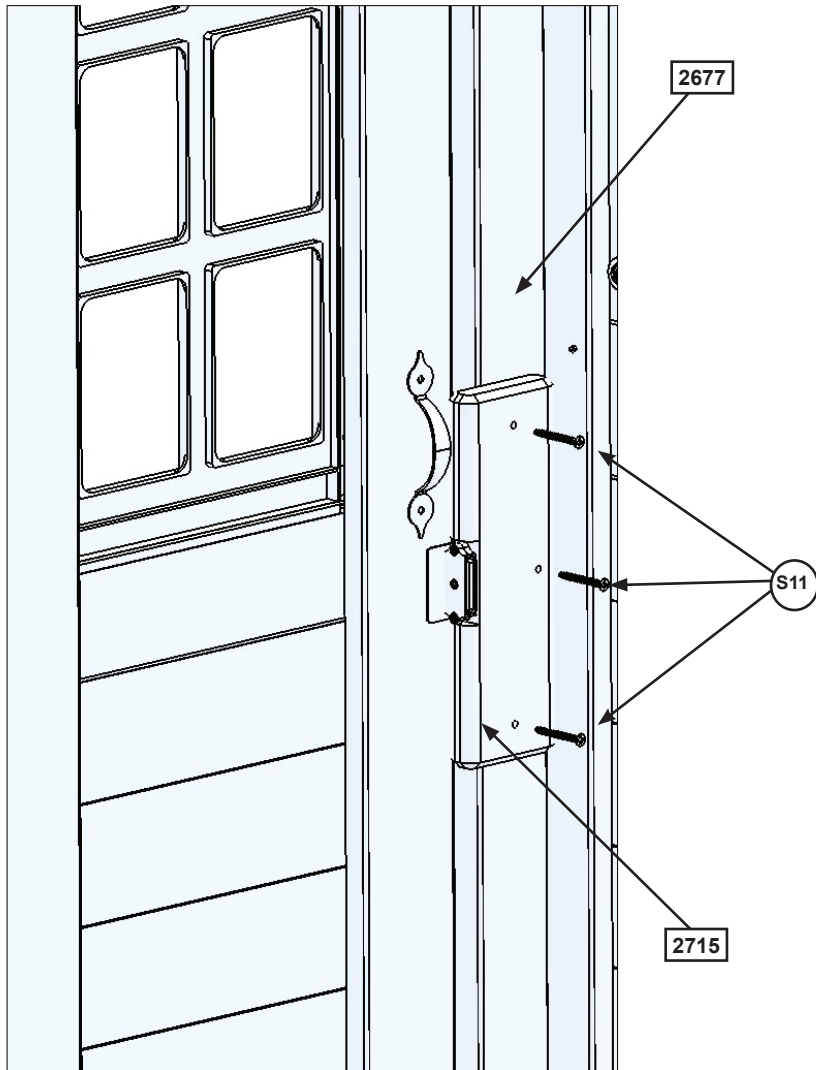

Fig. 19.1

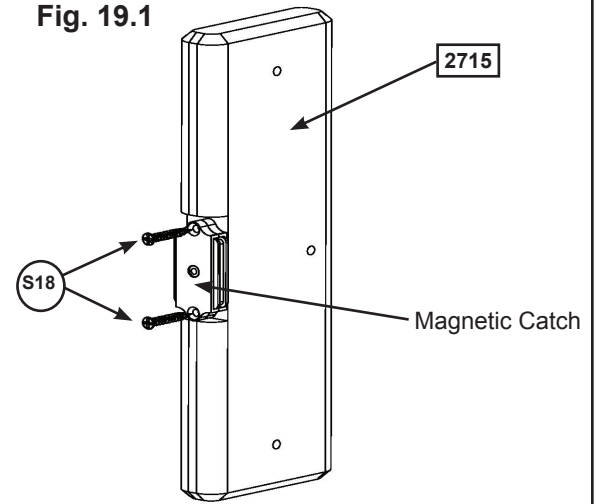
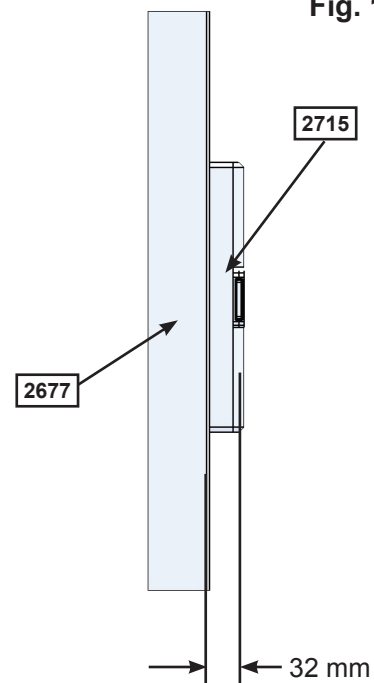

Fig. 19.3



Wood Parts

1 x **2715** Door Stop 25.4 mm x 63.5 mm x 254 mm

Hardware

2 x **S18** #6 x 25.4mm Wood Screw

3 x **S11** #8 x 50.8mm Wood Screw

Other Parts

1 x Magnetic Catch

Step 20: Slide Section Assemblies Part 1



Note: When installing Pan Bolts make sure to look at holes so bolts go through the side with the round recess and the lock nuts go through the side with the hexagonal recess. (fig. 20.3)

A: Fit 2 TNR2 Slide Elbows together and attach with 8 (PB1) Pan Bolts (with lock nut) as shown in fig. 20.1. It is very important to attach bolts as indicated.

B: Repeat Step A 3 more times to create 4 Elbow Sections in total.

C: Attach TNR3 Extend Flange RT and TNR3 Extend Flange LT together using 9 (PB1) Pan Bolts (with lock nut) as shown in fig. 20.2. This creates the Flange Assembly.

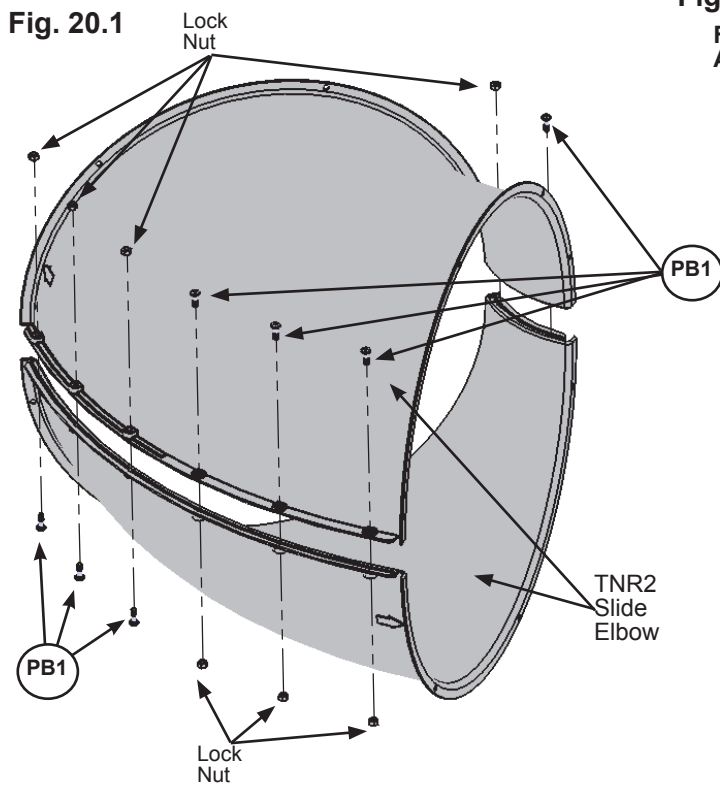

Fig. 20.2
Flange Assembly

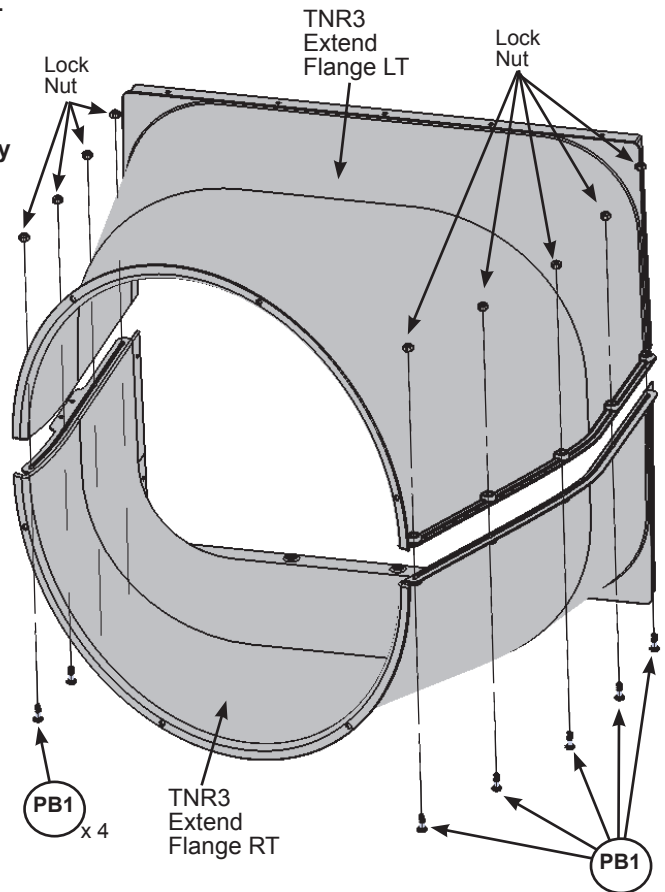
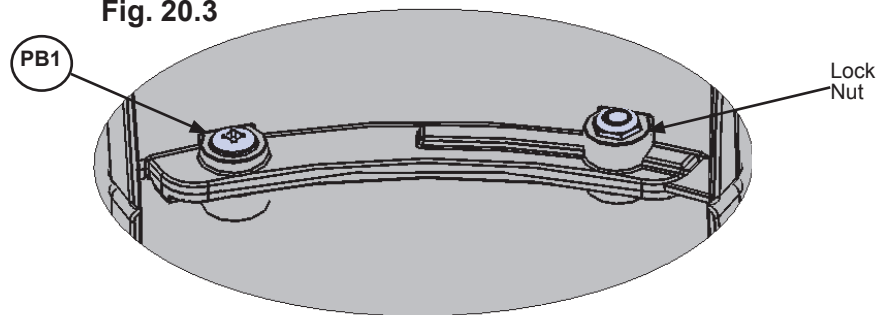

Fig. 20.3



Use a 11.1 mm open end wrench for nuts

Hardware

41 x 6.4 x 19.1mm Pan Bolt
(6.4 mm lock nut)

Other Parts

1 x TNR3 Extend Flange RT
1 x TNR3 Extend Flange LT
8 x TNR2 Slide Elbow

Step 20: Slide Section Assemblies Part 2

Note: When installing Pan Bolts make sure to look at holes so bolts go through the side with the round recess and the lock nuts go through the side with the hexagonal recess. (fig. 20.5)

D: Attach TNR2 Slide Exit Top and the remaining TNR2 Slide Elbow together using 8 (PB1) Pan Bolts (with lock nut) as shown in fig. 20.4. It is very important to attach bolts as indicated. This creates the Exit Elbow Assembly.

Fig. 20.4

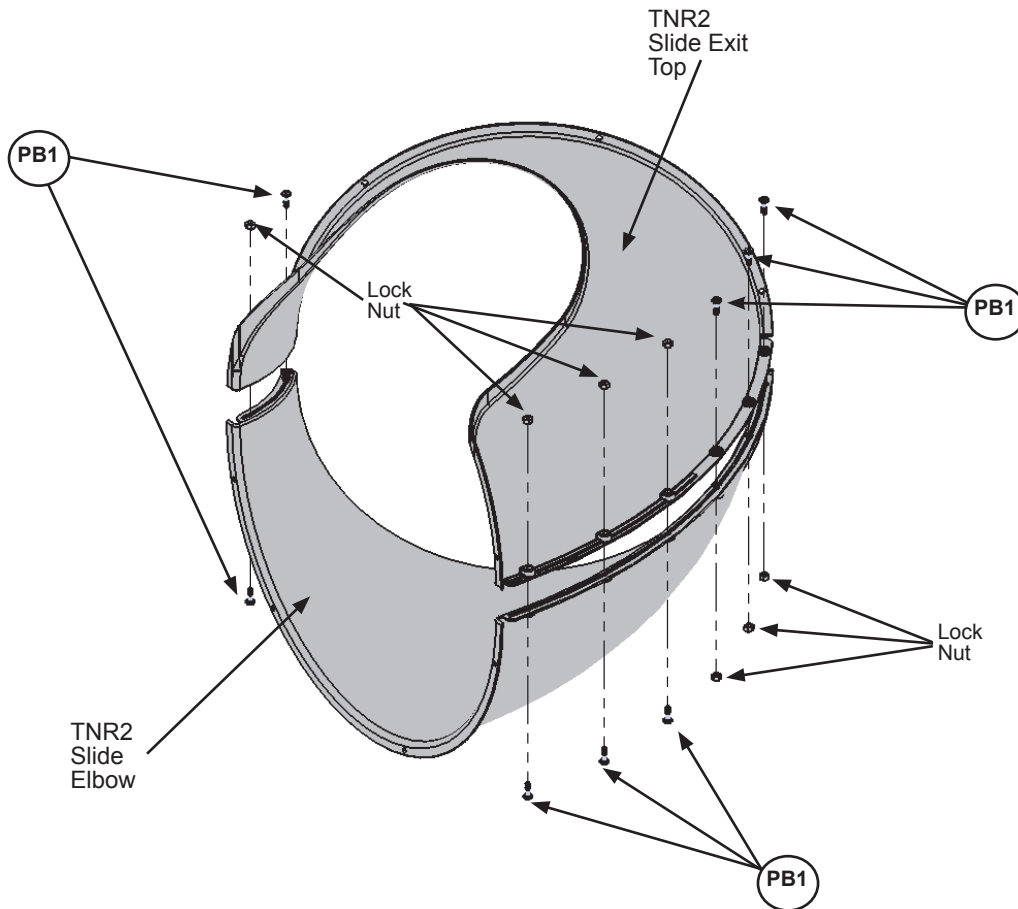
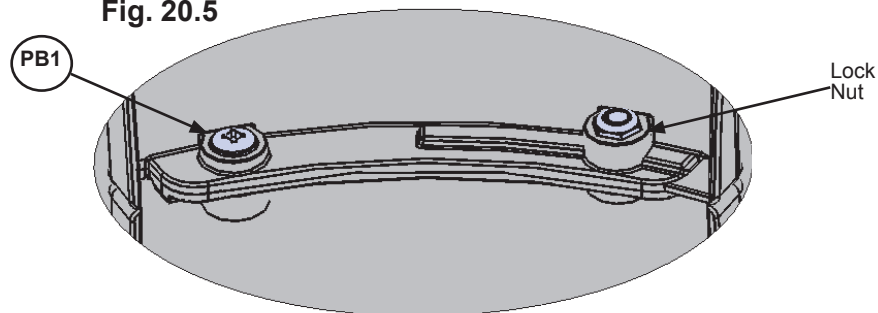

Fig. 20.5



Hardware

8 x (PB1) 6.4 x 19.1mm Pan Bolt
(6.4 mm lock nut)

Other Parts

1 x TNR2 Slide Exit Top
1 x TNR2 Slide Elbow

Step 21: Attach Elbow Assembly to Flange Assembly

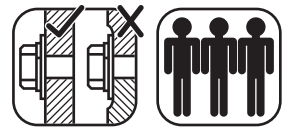

Note: Keep all bolts loose until further step.

A: Fit one of the Elbow Assemblies to the Flange Assembly by lining up the arrows on each assembly. Attach Elbow Assembly to Flange Assembly using 6 (PB1) Pan Bolts and Square Lock Nut. (fig. 21.1, 21.2 and 21.3)

B: Attach one of the Elbow assemblies to another Elbow Assembly making sure to line up the arrows on each assembly. Attach 6 (6.4 x 12.7) mm Pan Bolt with Square Lock Nut. Repeat this instruction for 2 more. (fig. 21.2, 21.3 and 21.4)

Use Quadrex Driver as a guide pin for each hole before inserting bolt.

Fig. 21.3

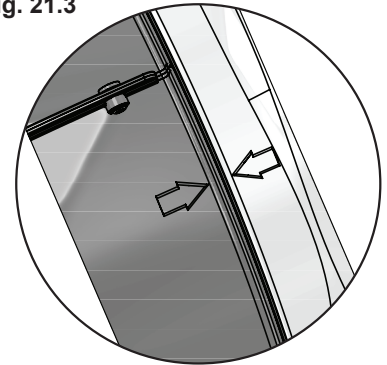

Align each elbow using the molded arrows.

Fig. 21.1

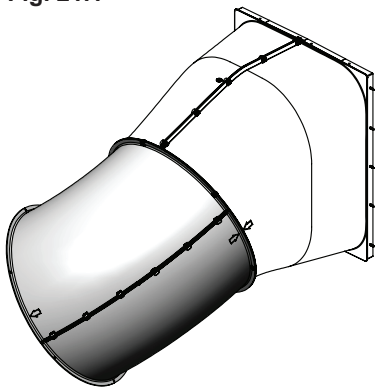

Fig. 21.2
Top Slide Bolt Holes

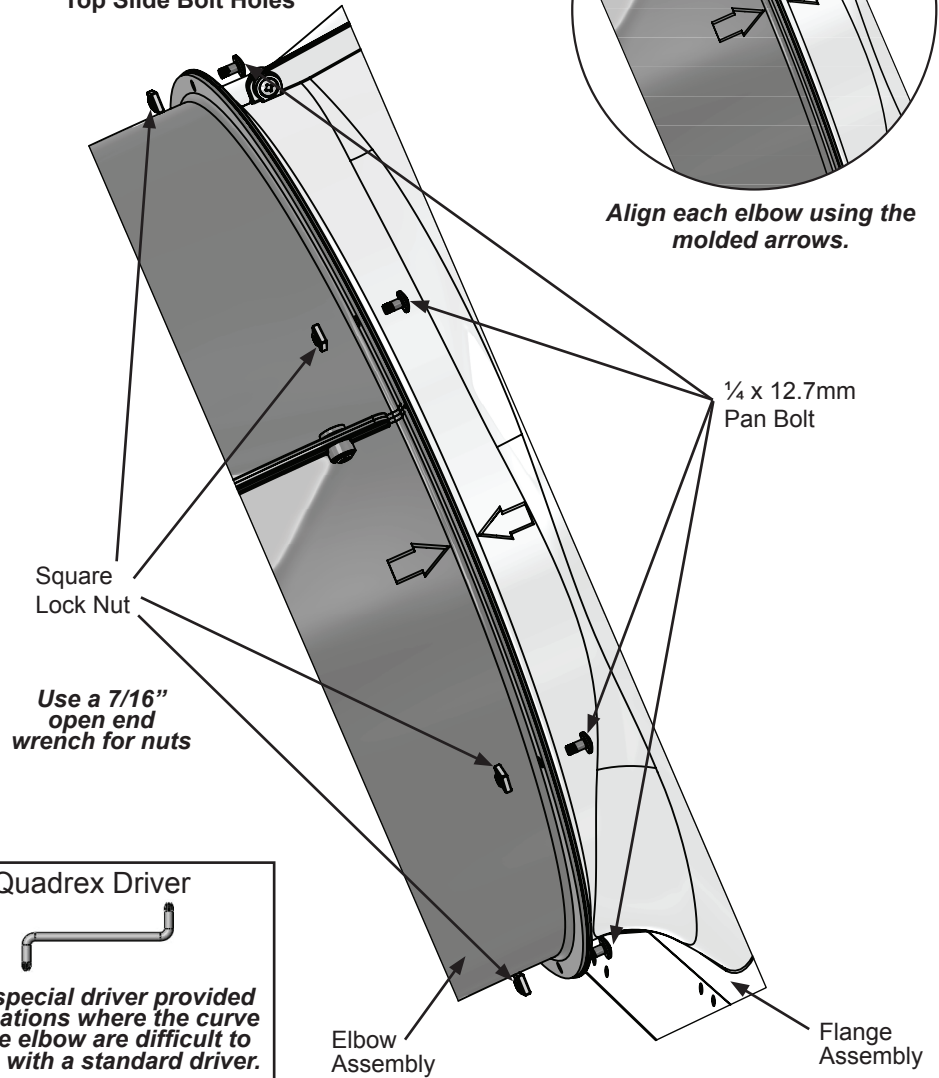
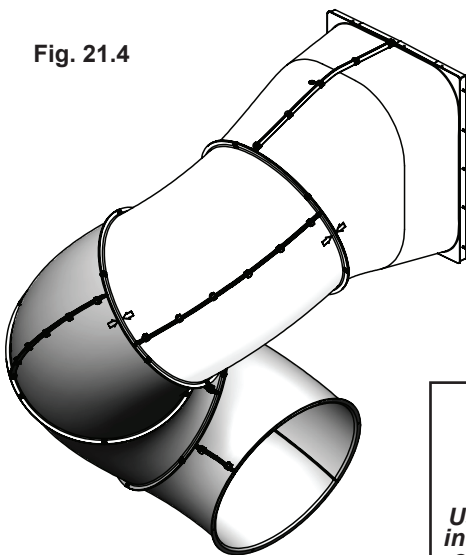

Fig. 21.4



Quadrex Driver



Use special driver provided in locations where the curve of the elbow are difficult to reach with a standard driver.

Other Parts

- 1 x Quadrex Driver
- 24 x 6.4 x 12.7mm Pan Bolt
- 24 x 6.4mm Square Lock Nut

Step 22: Attach TNR 3 Slide Exit to Elbow Assembly



A: Insert flange of Exit Elbow Assembly (slide elbow) into the slots on TNR3 Short Exit. (fig. 22.1)

B: Rotate Slide Exit and use Quadrex Driver as a guide pin so the holes are aligned and attach with 5 (PB1) Pan Bolts (with lock nuts) starting with the bottom middle hole and working up each side. (fig. 22.2 and 22.3)

C: At this point make sure all the slide bolts are tight.

Use a 11.1 mm open end wrench to hold nut and then tighten bolt with Quadrex Driver.

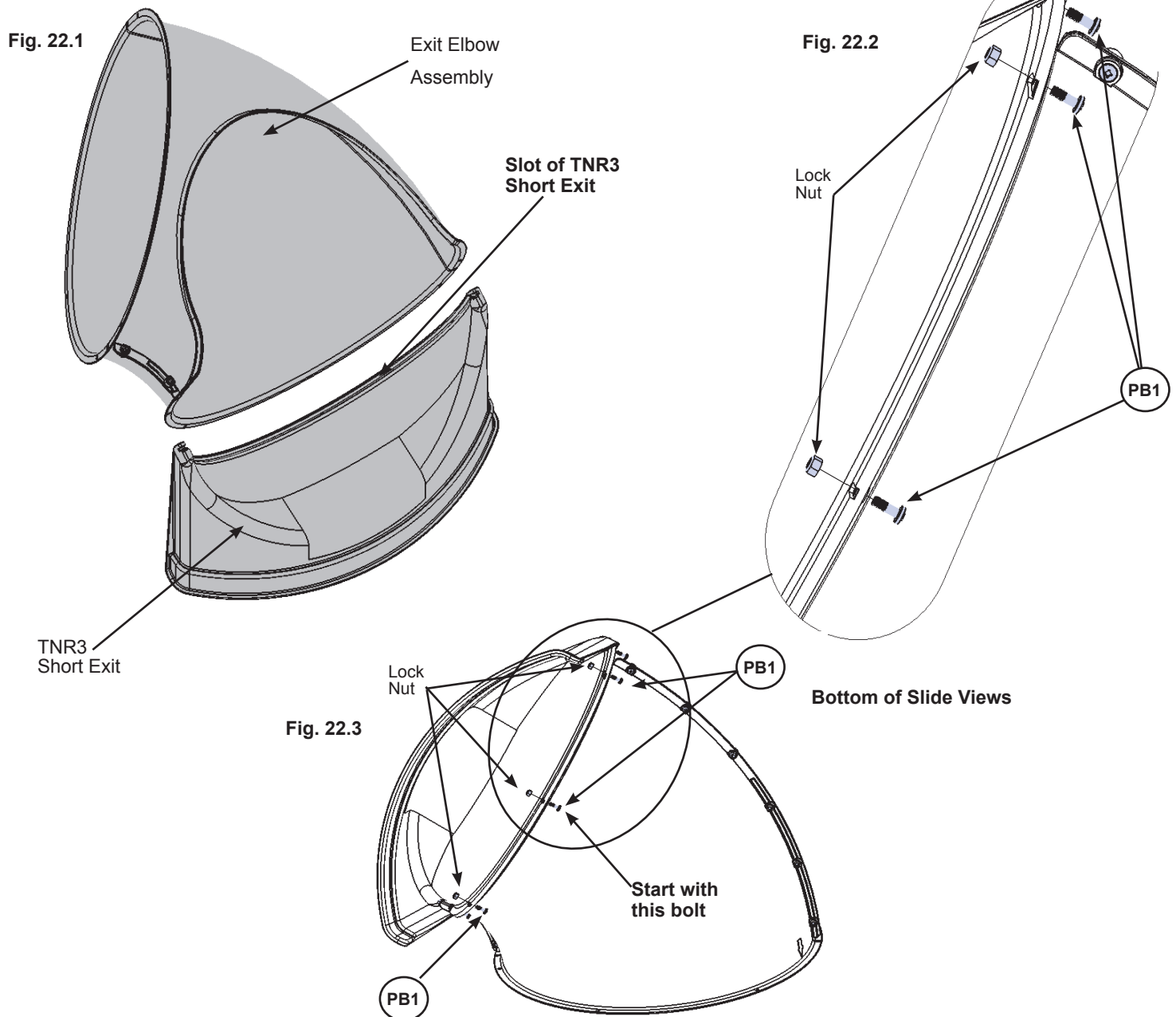

Hardware

5 x  6.4 x 19.1mm Pan Bolt
(6.4 mm lock nut)

Other Parts

1 x TNR3 Short Exit

Step 23: Attach Exit End Assembly



A: Fit the Exit End Assembly to the last Elbow Assembly by lining up the arrows on each assembly. Notice the elbow orientation. (fig. 23.1). Attach with 6 (6.4 x 12.7)mm Pan Bolts and Square Lock Nuts. (fig. 23.2)

Tighten all slide bolts before the clamp rings go on in the next step.

Fig. 23.2

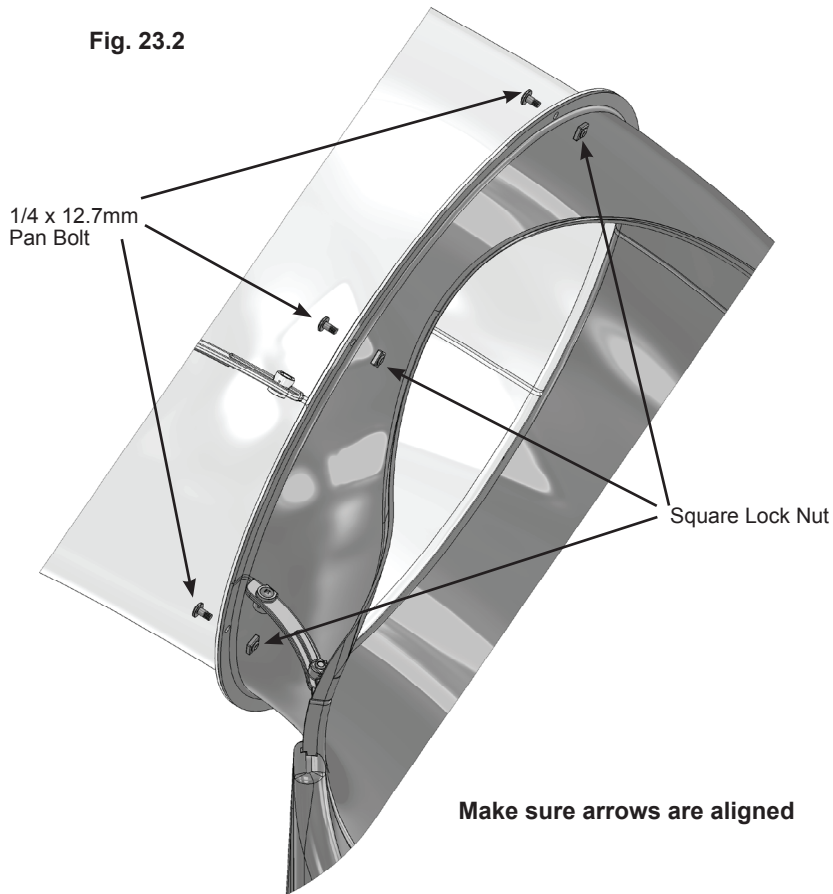

Fig. 23.1

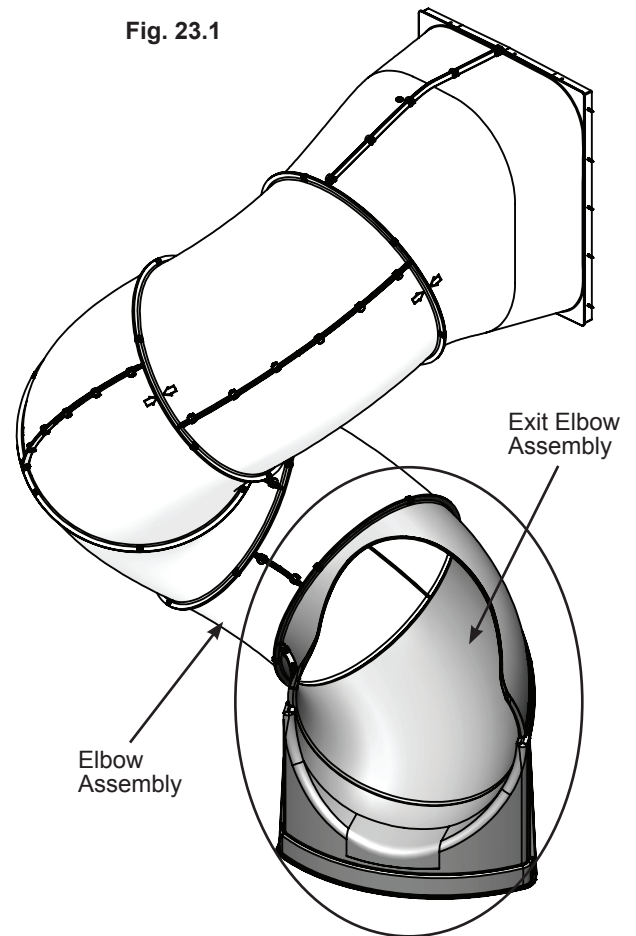
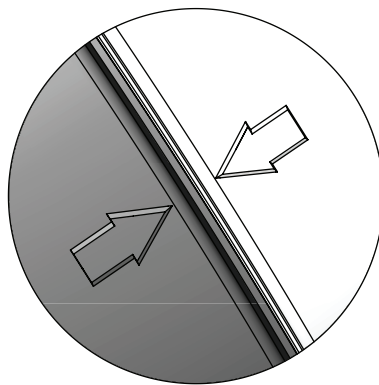

Fig. 23.3



Align each elbow using the molded arrows.

Other Parts

- 6 x 6.4 x 12.7mm Pan Bolt
- 6 x 6.4mm Square Lock Nut



Step 24: Attach TNR 4 Clamp Rings

A: Place 2 TNR4 Clamp Rings around each joint making sure to match the arrows with the end of the Clamp Ring as shown in (fig. 24.1 & 24.2).

B: Connect TNR4 Clamp Rings in 2 spots using 1 (PB6) Pan Bolt (with lock nut) per side. (fig. 24.3)

Note: When installing Pan Bolts make sure to look at holes so bolts go through the side with the round recess and the lock nuts go through the side with the hexagonal recess.

Fig. 24.1

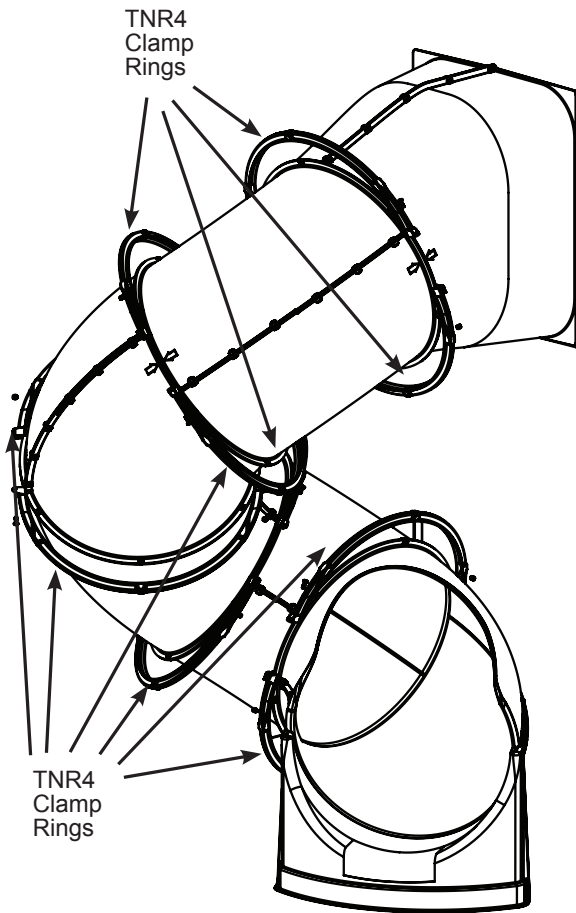

Note: For ease of assembly the bottom set of clamp rings can be turned 90 degrees to install bolts.

Fig. 24.2

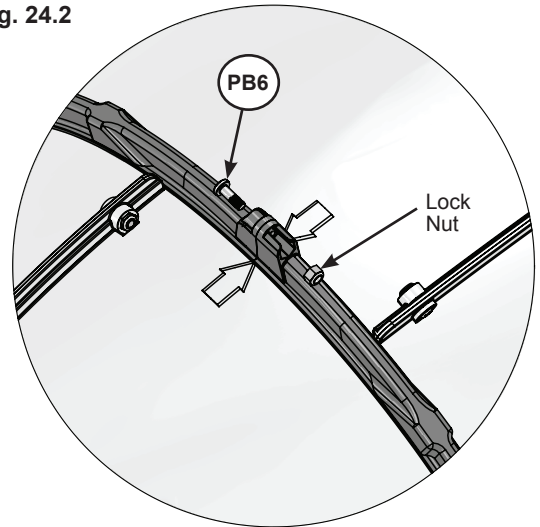

Make sure arrows are aligned

Fig. 24.3

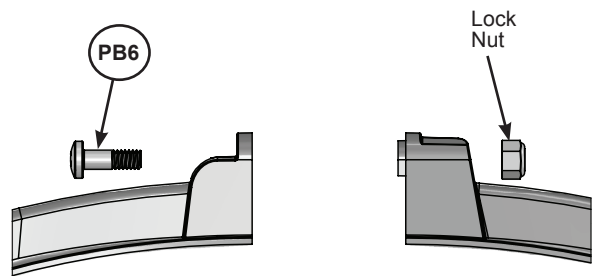

After the clamp rings are attached to the elbows, fasten them end to end with two pan bolts and lock nuts

Hardware

10 x  6.4 x 25.4mm Pan Bolt
(6.4 mm lock nut)

Other Parts

10 x TNR4 Clamp Ring

Step 25: Attach Flange Assembly to Fort Part 1

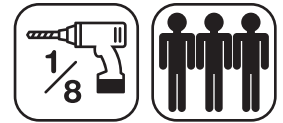

Note: Structure partly removed for clarity.

A: With a helper place the Flange Assembly flush to the top opening in (2622) End Panel Assembly as shown in fig. 25.1, then pre-drill 3.2 mm pilot holes in (8935) Lower SL Insert for the 4 bottom mounting locations (approximate spots where circles are on figure), making sure the pre-drilled holes are a minimum of 25.4 mm deep. (fig. 25.2)

B: Attach Flange Assembly to (8935) Lower SL Insert using 4 (S7) Pan Screws (with #12 Screw Bezel) in the pre-drilled holes. (fig. 25.2) Make sure the flat surfaces of the Flange Assembly are flush to the (2622) End Panel Assembly and (2602) Upper Jamb as shown in fig. 25.3.

C: Attach the Flange Assembly flush to top of (2622) End Panel Assembly using 4 (S6) Pan Screws (with #12 Screw Bezel) and to (2602) Upper Jamb and side of (2622) End Panel Assembly using 5 (S6) Pan Screws per side. (fig. 25.2)

Fig. 25.2
Inside View

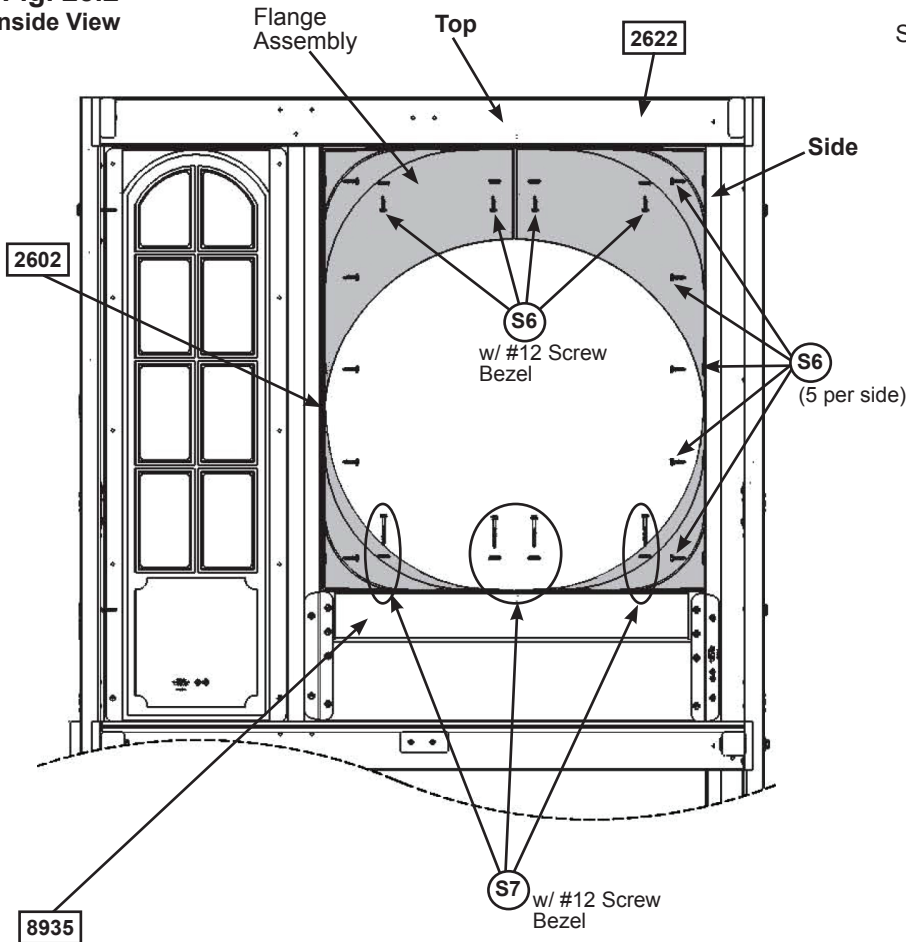

Fig. 25.1
Outside View

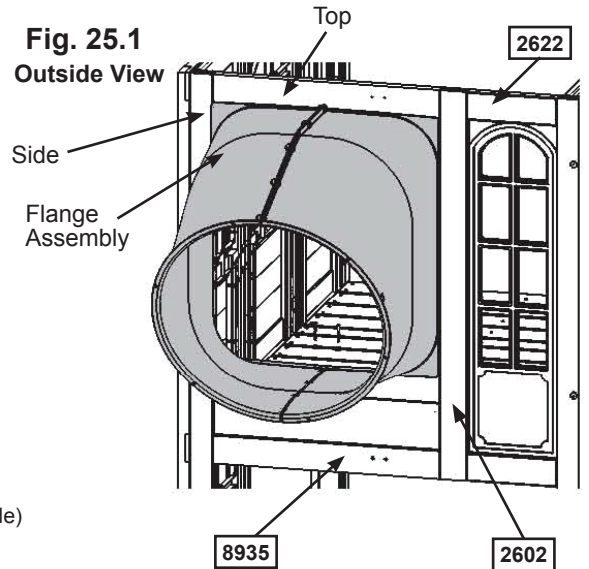
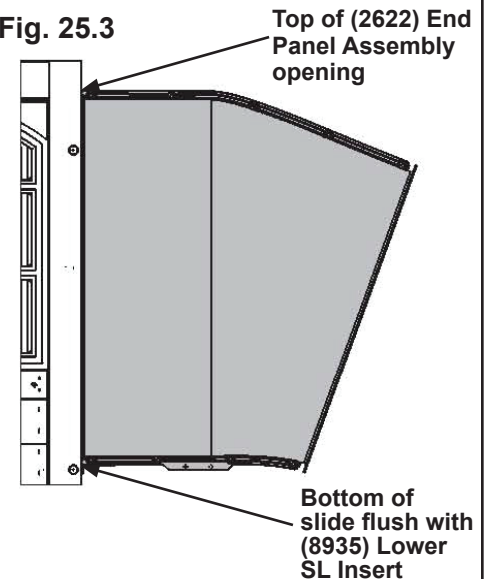



Fig. 25.3



Hardware

- 14 x  #12 x 25.4mm Pan Screw
- 4 x  #12 x 50.8mm Pan Screw
- 8 x #12 Screw Bezel

Step 25: Attach Flange Assembly to Fort Part 2



Note: Structure partly removed for clarity.

D: Place (8934) SL Gusset tight to (2622) End Panel Assembly, flush to the top of the bottom opening and attach to Flange Assembly with 2 (S6) Pan Screws. (fig. 25.4 and 25.5)

E: Pre-drill pilot hole with a 3 mm drill bit then attach (8934) SL Gusset to (2622) End Panel Assembly with 1 (WL5) Wafer Lag (with flat washer). (fig. 25.4 and 25.5)

Fig. 25.4

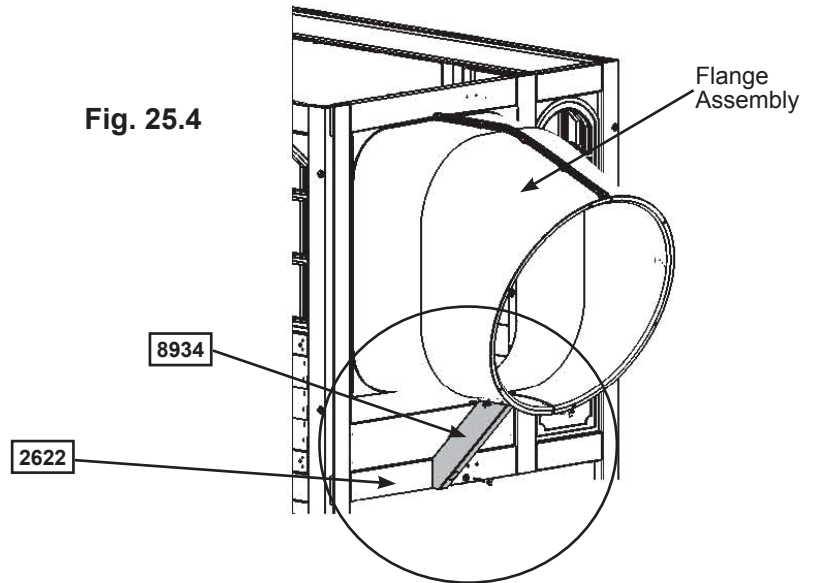
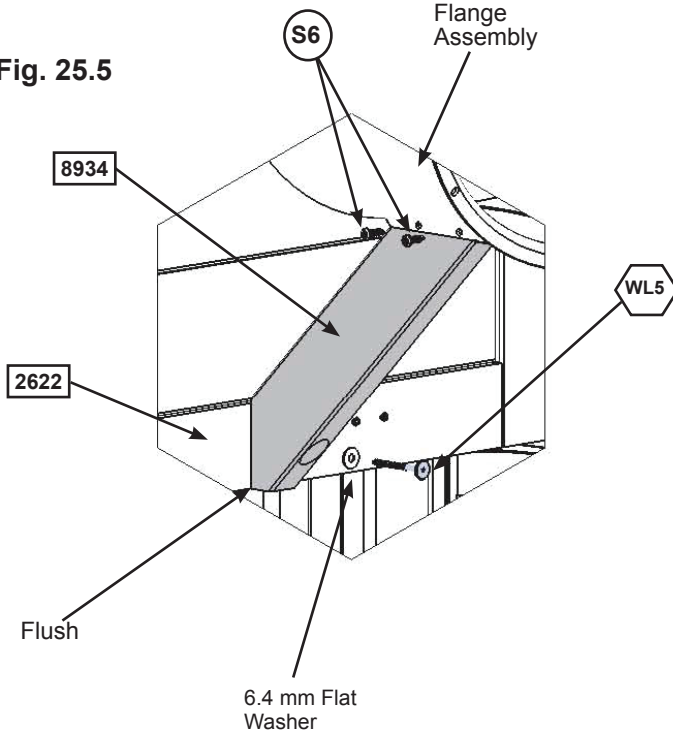

Fig. 25.5



Wood Parts

1 x **8934** SL Gusset 31.8 mm x 76.2 mm x 400 mm

Hardware

2 x **S6** #12 x 25.4mm Pan Screw

1 x **WL5** 6.4 x 63.5mm Wafer Lag (6.4 mm flat washer)

Step 26: TNR Brace Assembly



A: Attach (8965) TNR Upright to (8963) TNR Ground Brace with 1 (H8) Hex Bolt (with lock washer, flat washer and t-nut) in the top hole. Make sure both boards are square then attach with 1 (S11) Wood Screw. (fig. 26.1)

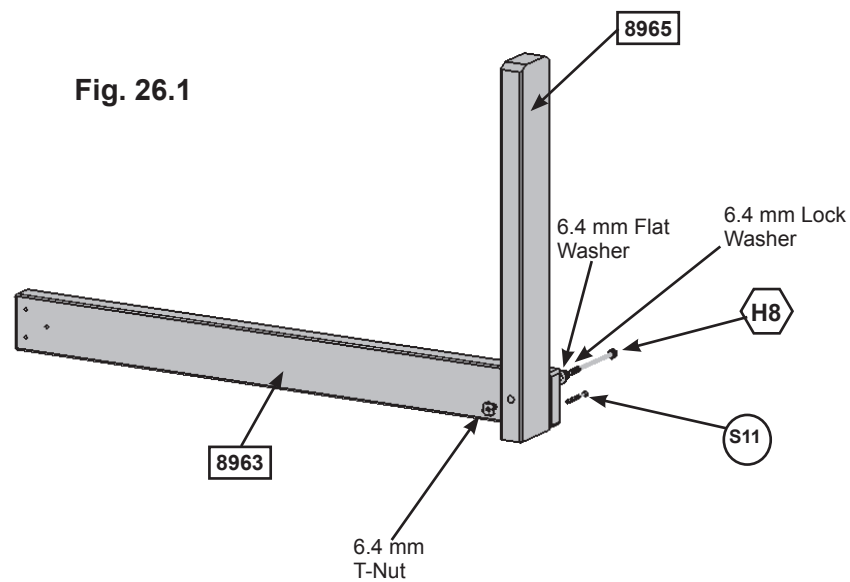

Note: Install T-nuts first!

Wood Parts

- 1 x 8963 TNR Ground Brace 31.8 mm x 76.2 mm x 819.2 mm
- 1 x 8965 TNR Upright 31.8 mm x 76.2 mm x 514.4 mm

Hardware

- 1 x S11 #8 x 50.8mm Wood Screw
- 1 x H8 6.4 x 108mm Hex Bolt
(6.4 mm lock washer, 6.4 mm flat washer, 6.4 mm t-nut)

Step 27: Attach TNR3 Tube Support to Fort



A: Place TNR Brace Assembly against (2618) Front Back Panel so it sits under the slide. It is not attached yet. (fig. 27.1)

B: On the fourth attached Elbow Assembly remove the pan bolt and nut which is facing the fort (installed in Step 20). (fig. 27.1) The bolt will no longer be needed, but keep the lock nut.

C: Loosely attach TNR3 Tube Support (at the slightly bent end) to the slide seam using 1 (PB6) Pan Bolt (with flat washer and the previously removed lock nut). (fig. 27.2)

D: Rotate TNR3 Tube Support and attach to Slide End Panel using 1 (S6) Pan Screw as shown in (fig. 27.2).

E: Fully tighten screw and bolt.

Fig. 27.2

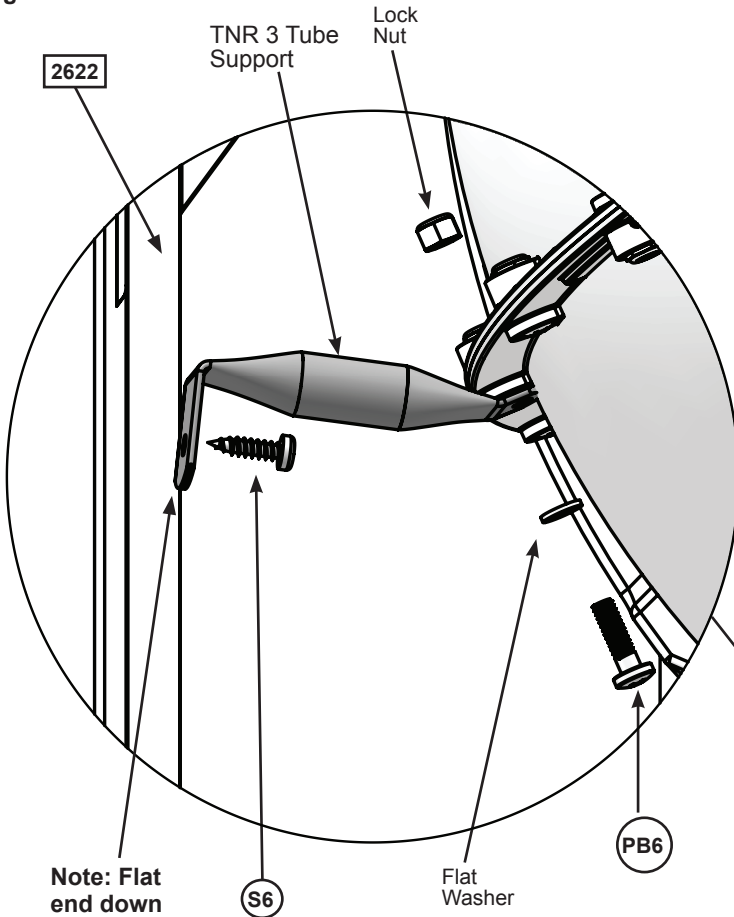

Remove PB1 (6.4 x 19.1mm Pan Bolt) first then install PB6 (6.4 x 25.4mm Pan Bolt with flat washer)

Fig. 27.1

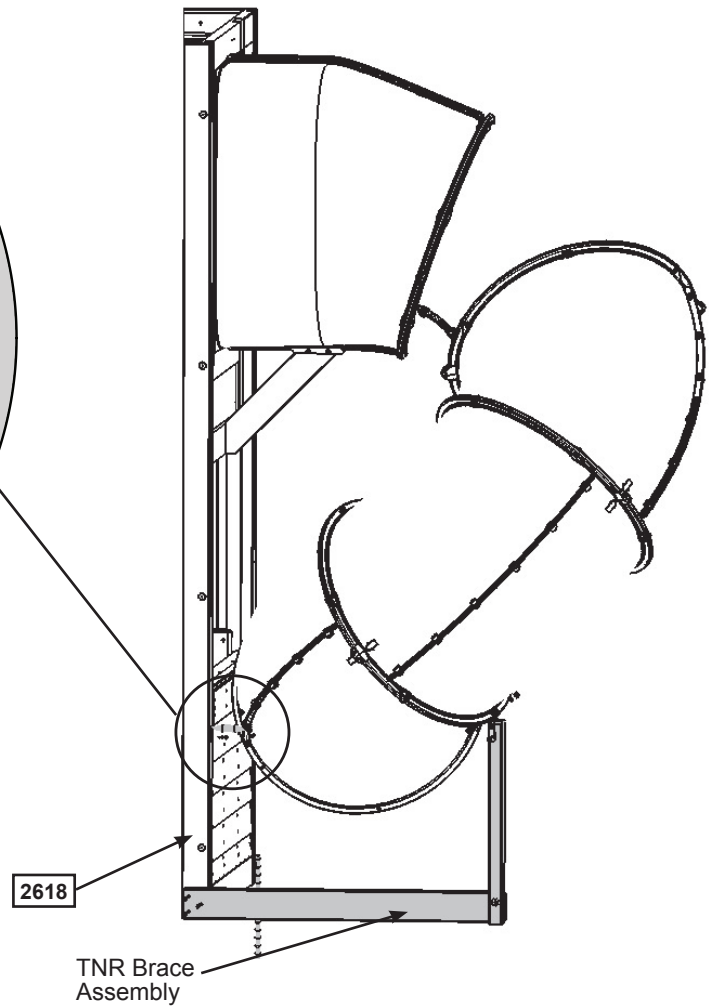

Hardware

- 1 x (S6) #12 x 25.4mm Pan Screw
- 1 x (PB6) 6.4 x 25.4mm Pan Bolt
(6.4 mm flat washer & 6.4 mm lock nut - previously removed)

Other Parts

- 1 x TNR3 Tube Support

Step 28: Attach Elbow Assemblies and TNR4 Slide

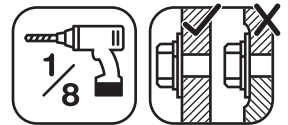

- A:** Place 1 TNR4 Post Mount Clamp on either side of the Clamp Ring so that the bent tops clip in behind the Clamp Ring. (fig. 28.2)
- B:** Insert the TNR4 Post Mount Base in between the 2 Post Mount Clamps and screw all pieces together using 6.4 x 14.5 mm Pan Head Bolt and Square Nylock Nut. (fig. 28.2)
- C:** Attach TNR4 Post Mount Base to (8965) TNR Upright, pre-drill with a 3 mm drill bit then attach with 2 (S6) Pan Screws. (fig. 28.2)
- D:** Attach the Post Mount Clamp to the clamp ring using 1 (S37) Pan Screw. (fig. 28.2)
- E:** Attach (8963) TNR Ground Brace flush to the bottom of (2618) Front Back Panel with 2 (S11) Wood Screws and 1 (S4) Wood Screw. (fig. 28.1 and 28.3)

Fig. 28.1

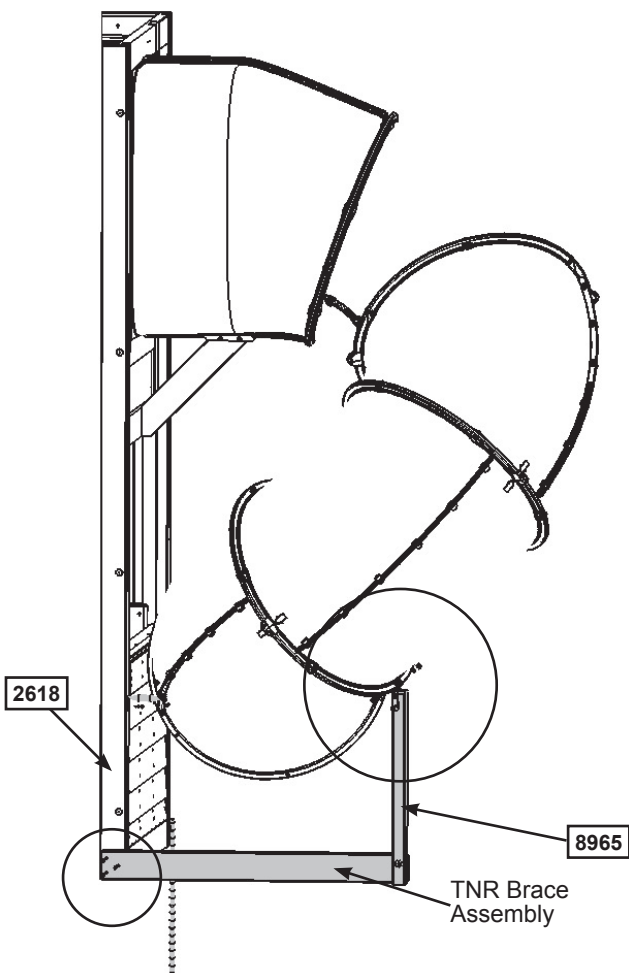

Fig. 28.2

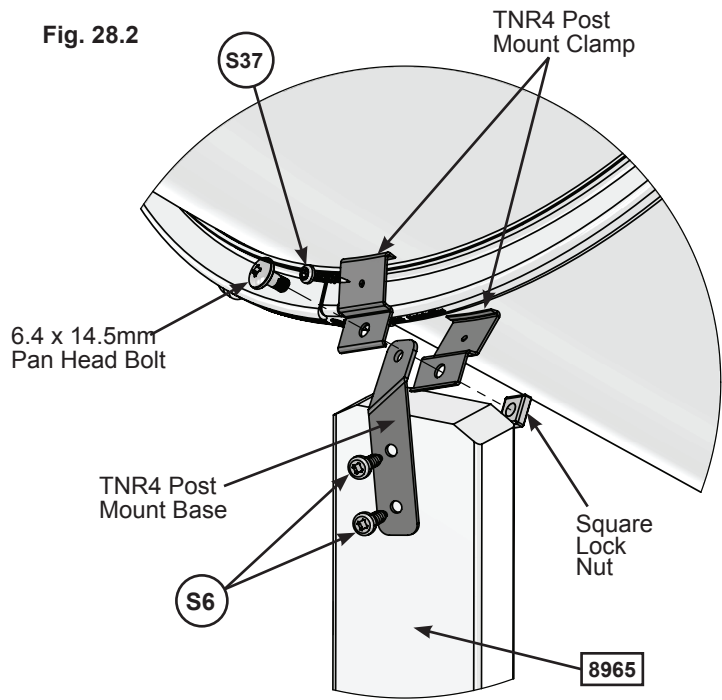
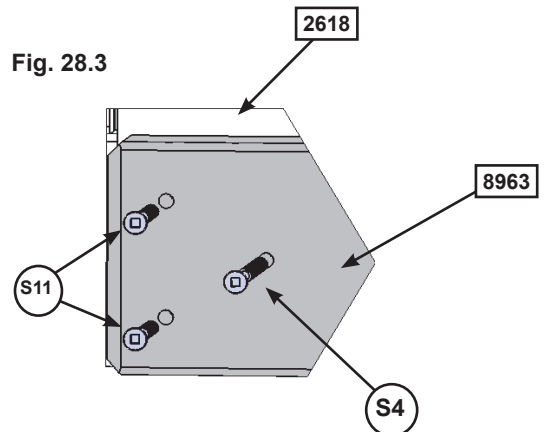

Fig. 28.3



Hardware

- 2 x (S6) #12 x 25.4mm Pan Screw
- 1 x (S4) #8 x 76.2mm Wood Screw
- 1 x (S37) #7 x 15.9mm Pan Screw
- 2 x (S11) #8 x 50.8mm Wood Screw

Other Parts

- 2 x TNR4 Post Mount Clamp
- 1 x TNR 4 Post Mount Base
- 1 x 6.4 x 14.5 mm Pan Head Bolt
- 1 x Square Lock Nut

Step 29: Attach Ground Stake to TNR Upright

A: In the spot shown in fig. 29.1 drive 1 Rebar Ground Stake 330 mm into the ground against the (8965) TNR Upright. Be careful not to hit the washer while hammering stake into the ground as this could cause the washer to break off.

B: Attach the ground stake to (8965) TNR Upright just below the t-nut using 1 (S7) Pan Screw as shown in fig. 29.2.

C: After driving stakes into the ground, check for sharp edges caused by the impact of the hammer. Smooth any sharp edges from impact area and touch up with outdoor paint.

 **Warning!** To prevent tipping and avoid potential injury, stakes must be driven 330 mm into ground. Digging or driving stakes can be dangerous if you do not check first for under-ground wiring, cables or gas lines.

Fig. 29.1

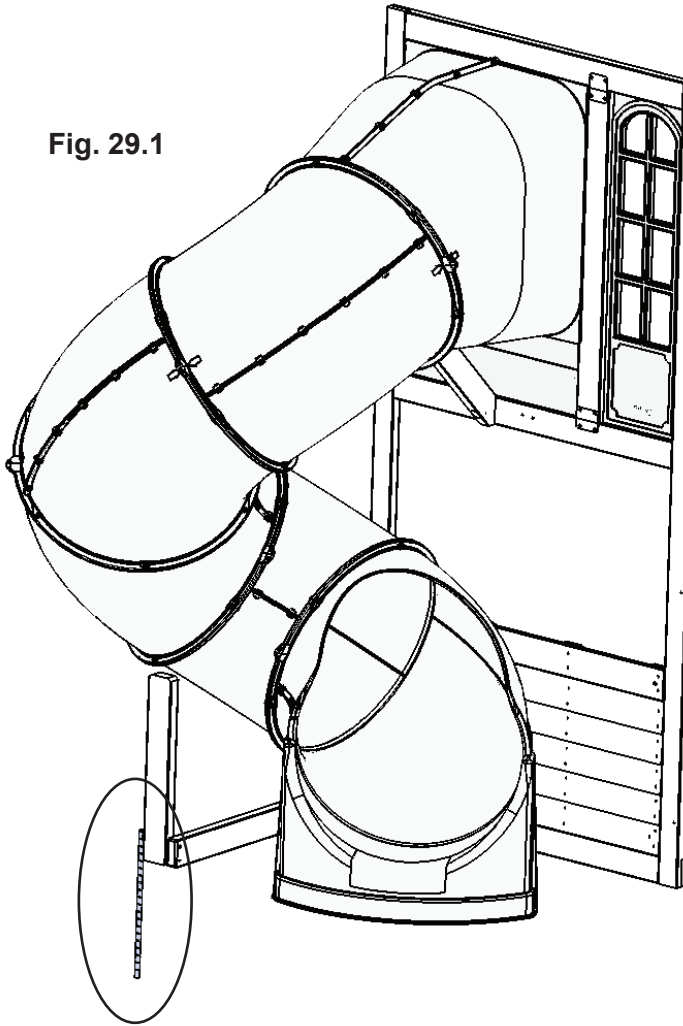
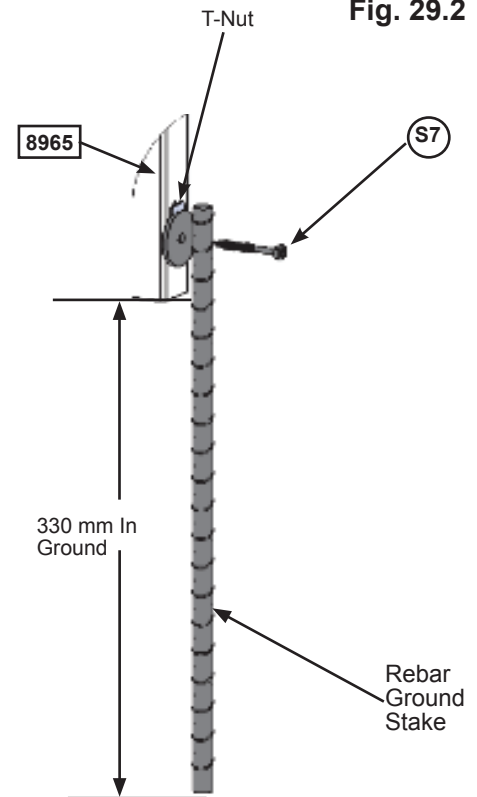

Fig. 29.2



Hardware

1 x  #12 x 50.8mm Pan Screw

Other Parts

1 x Rebar Ground Stakes

Step 30: Roof Support Assembly

A: Attach 1 (2617) Roof Support to a second (2617) Roof Support at peak using 1 (S4) Wood Screw. Repeat this step so there are 2 Roof Support Assemblies. (fig. 30.1 and 30.2)

Fig. 30.1

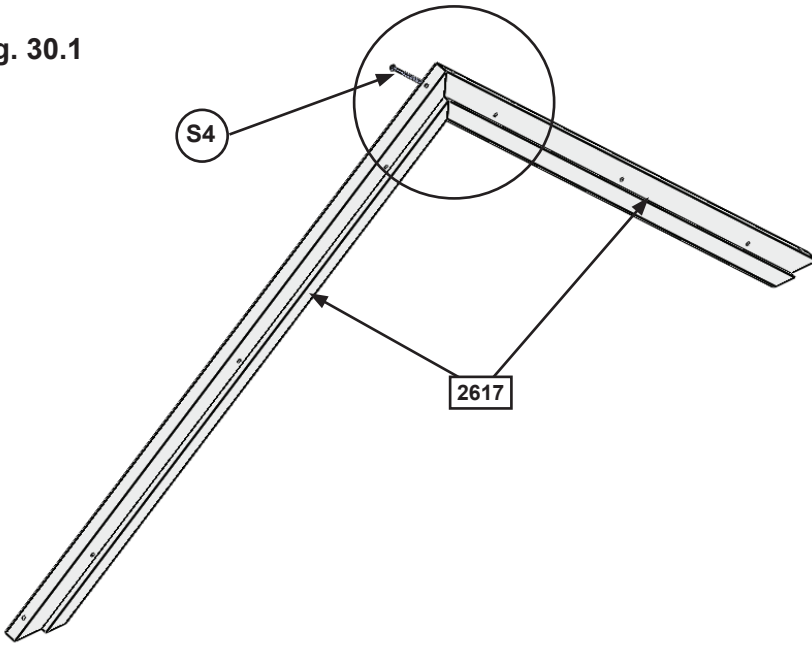

Roof Support Assembly

Fig. 30.2

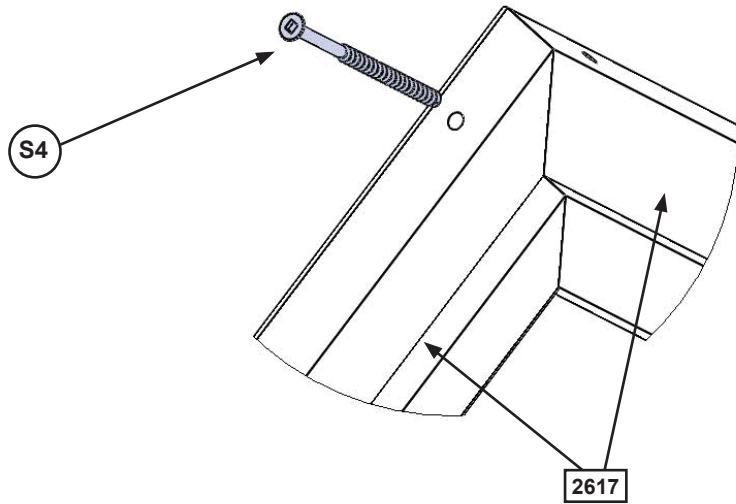

Wood Parts

4 x **2617** Roof Support 31.8 mm x 57.2 mm x 952.5 mm

Hardware

2 x **S4** #8 x 76.2mm Wood Screw

Step 31: Roof Assembly Part 1



A: Place (2644) Front Roof Panel against (2639) Back Roof Panel so the tops form a peak then tight to the inside edge of the outside slats attach 1 Narrow Angle Bracket per slat with 2 (S0) Truss Screws per bracket. (fig. 31.1 and 31.2)

B: Attach the third Narrow Angle Bracket centred on the middle slat with 2 (S0) Truss Screws. (fig. 31.1 and 31.3)

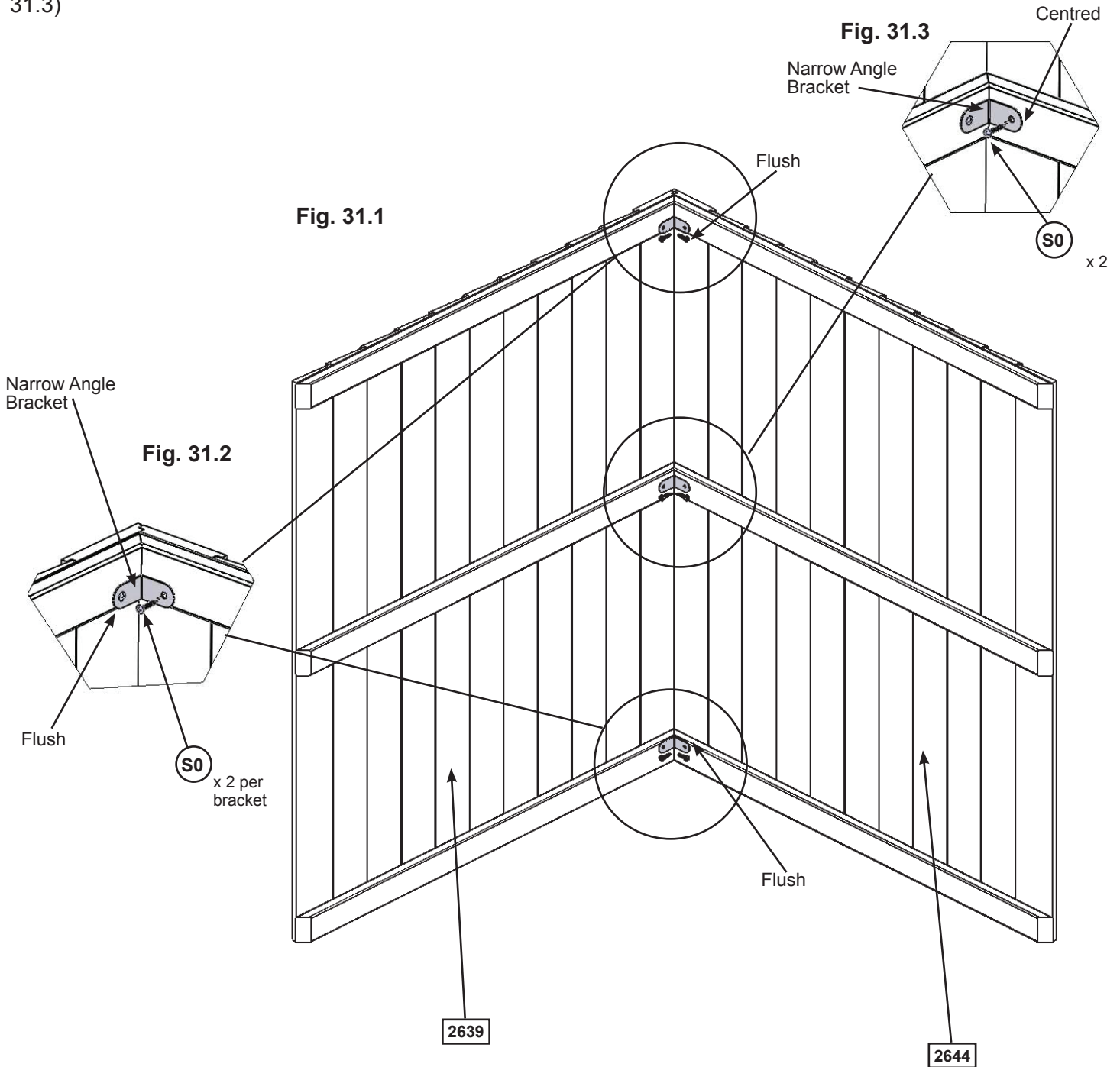

Wood Parts

- 1 x 2644 Front Roof Panel 31.8 mm x 939.8 mm x 1117.6 mm
- 1 x 2639 Back Roof Panel 31.8 mm x 933.5 mm x 1117.6 mm

Hardware

- 6 x S0 #8 x 22.2mm Truss Screw

Other Parts

- 3 x Narrow Angle Bracket

Step 31: Roof Assembly Part 2

C: Place 1 Roof Support Assembly against one side so the peaks meet and the ends of the roof supports are flush with the ends of the roof panels. Attach with 6 (S11) Wood Screws. (fig. 31.4)

D: Attach the second Roof Support Assembly on the opposite side, peaks to meet and ends are flush with 6 (S11) Wood Screws. (fig. 31.4)

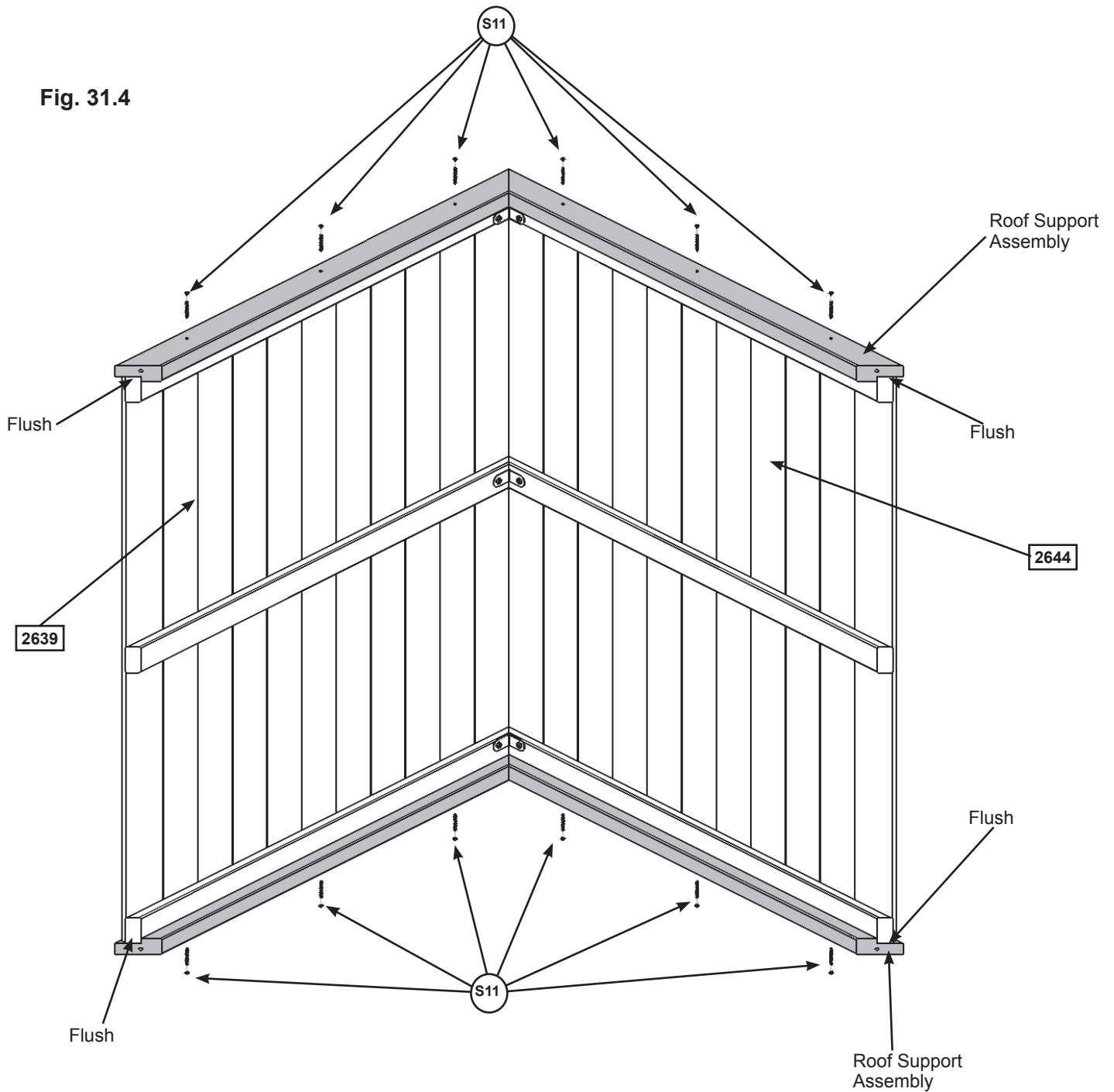

Hardware

12 x  #8 x 50.8mm Wood Screw

Step 32: Attach Sky Gable

A: Attach 1 Sky Gable to the inside of the (2617) Roof Supports on each side of the Roof Assembly with 4 (S5) Pan Screws per Sky Gable. (fig. 32.1 and 32.2)

Fig. 32.1

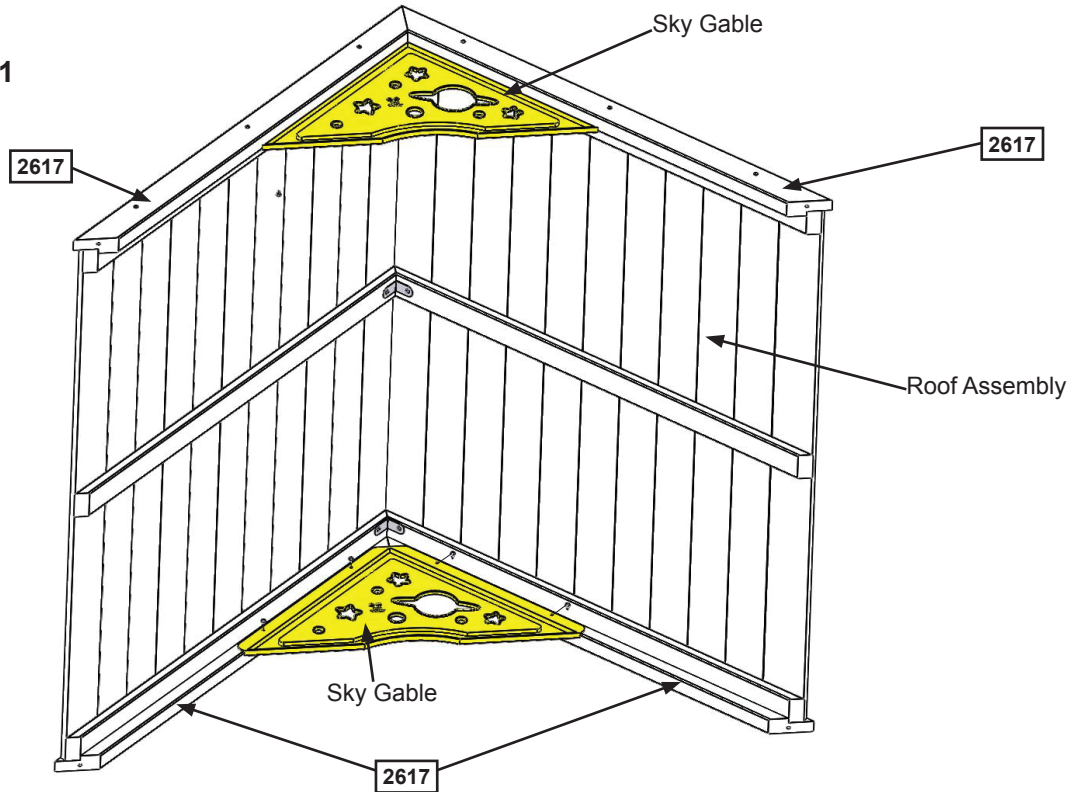
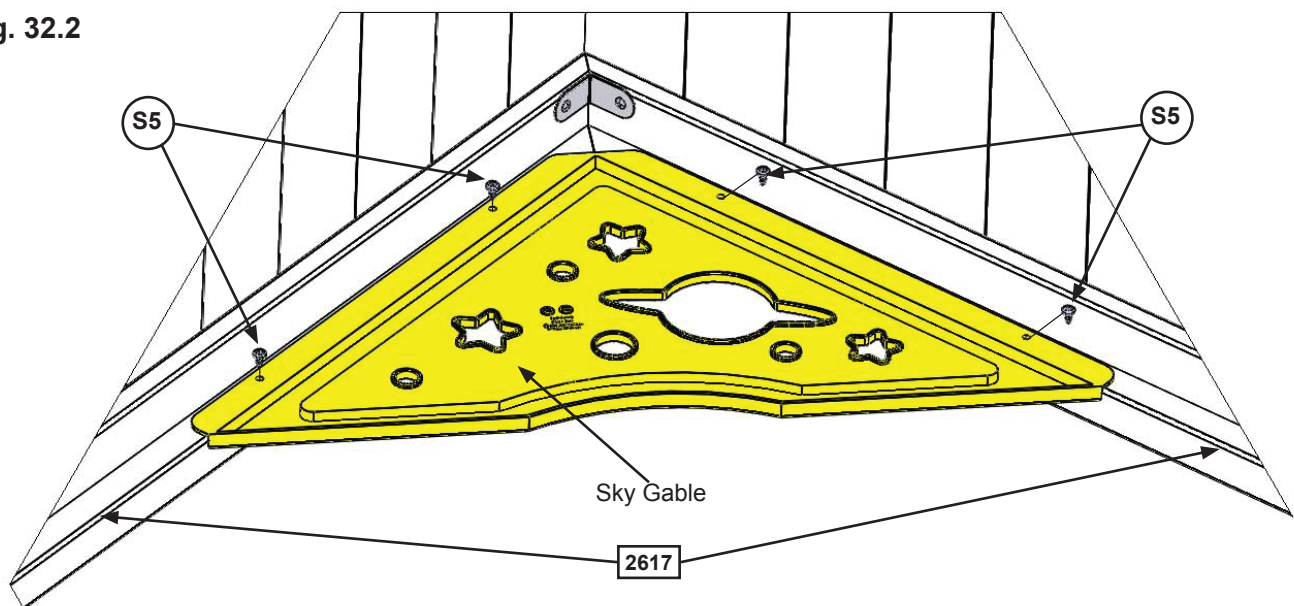

Fig. 32.2



Hardware

8 x  #8 x 12.7mm Pan Screw

Other Parts

2 x Sky Gable

Step 33: Attach Roof Ends



A: Place 2 (2646) Roof Ends flush to the top and right hand side of the panels and 2 (2647) Roof End Lefts flush to the top and left hand side of the panels, measure overhang so it is 123.8 mm then attach with 2 (S11) Wood Screws and 1 (S4) Wood Screw. (fig. 33.1, 33.2 and 33.3)

Fig. 33.1

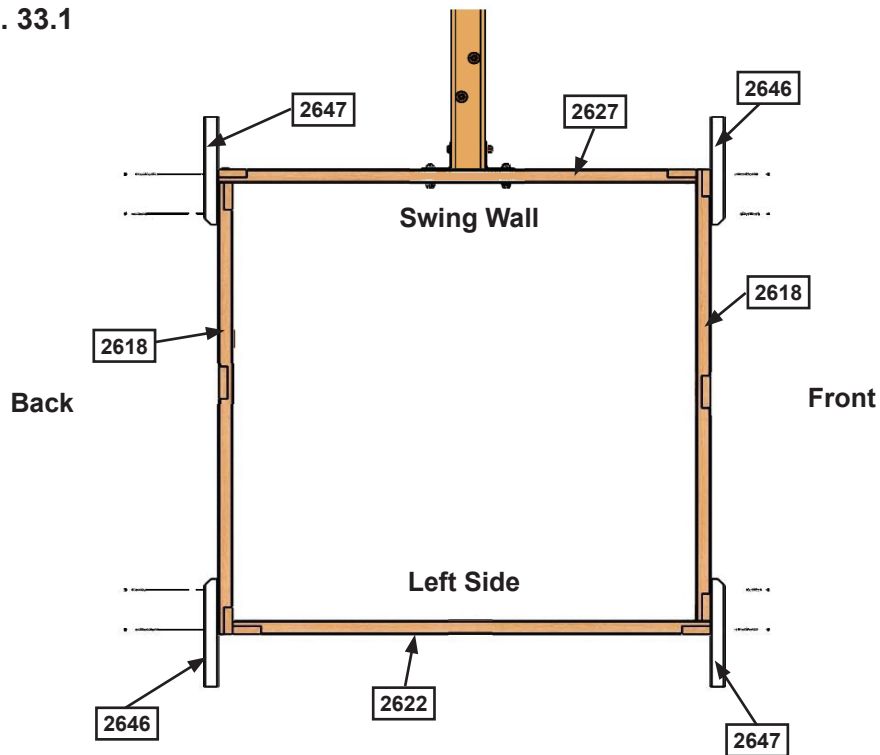

Fig. 33.2
Side View

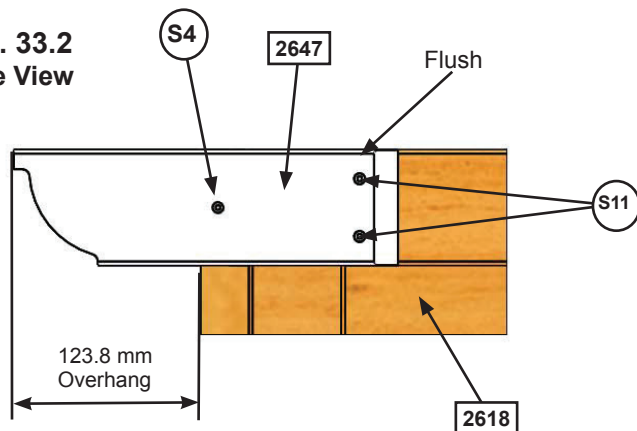
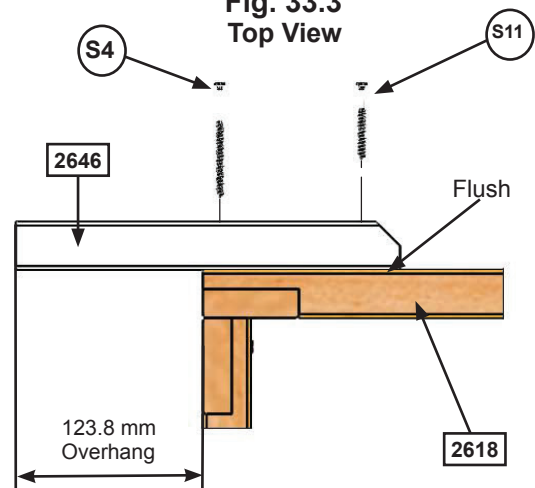

Fig. 33.3
Top View



Wood Parts

- 2 x 2646 Roof End 31.8 mm x 76.2 mm x 254 mm
- 2 x 2647 Roof End Left 31.8 mm x 76.2 mm x 254 mm

Hardware

- 4 x S4 #8 x 76.2mm Wood Screw
- 8 x S11 #8 x 50.8mm Wood Screw

Step 34: Attach Roof Assembly to Fort



A: With 2 people on the ground and at least 1 person in the fort, lift the Roof Assembly up and over the Back side of the fort. Guide the Roof Assembly onto the fort so all four (2617) Roof Supports sit flush to the front and outside edges of (2646) Roof End and (2647) Roof End Left. (fig. 34.1 and 34.2)

B: Attach (2617) Roof Supports to (2646) Roof End and (2647) Roof End Left with 1 (S3) Wood Screw per support. (fig. 34.2)

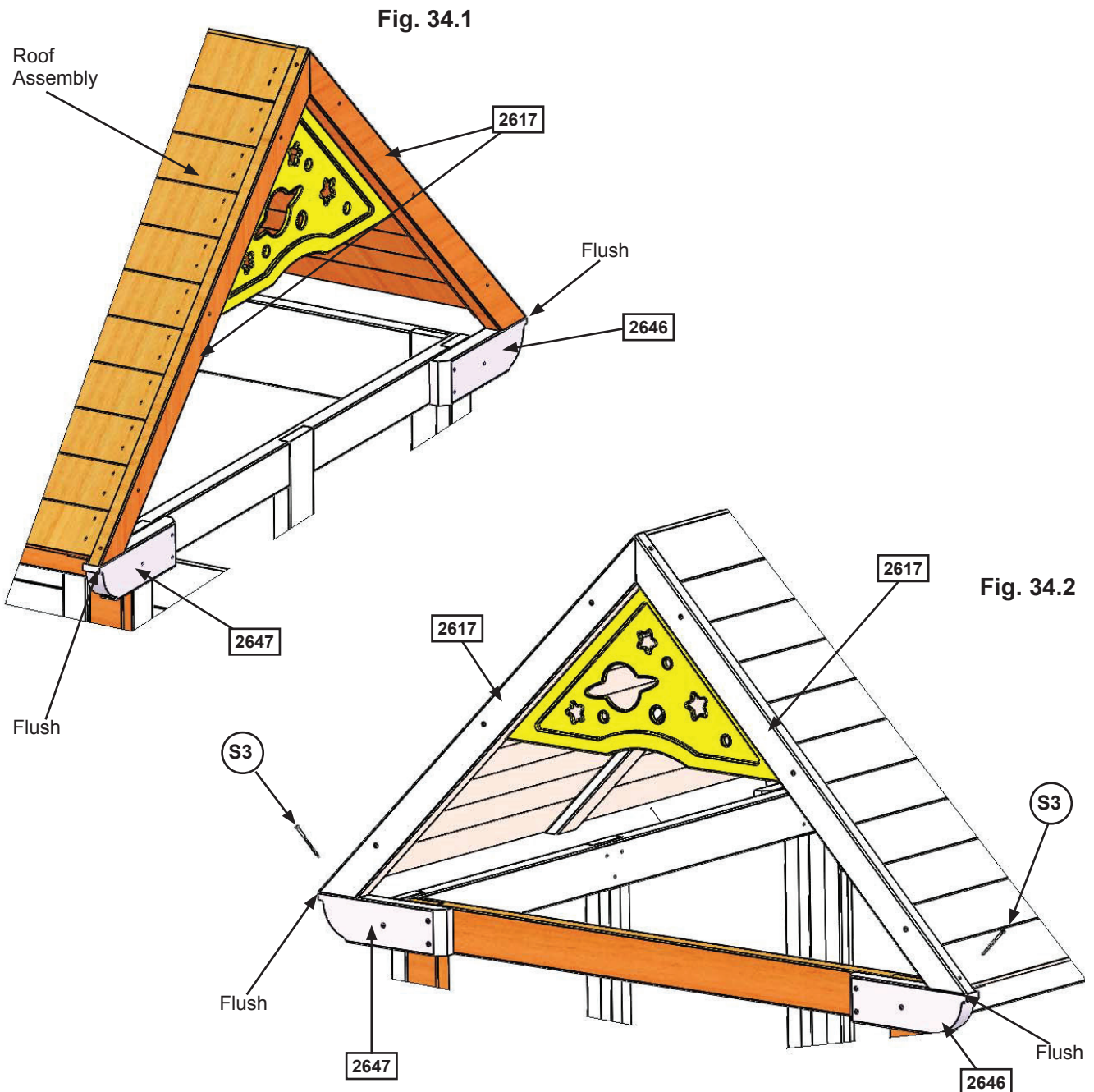

Hardware

4 x  #8 x 63.5mm Wood Screw

Step 35: Bench Assembly

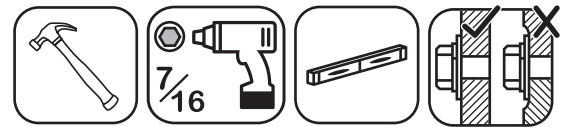

A: Open the (9501) Folding Bench Assembly. Secure with 2 (S2) Wood Screw per side. (fig. 35.1, 35.2 and 35.3)

B: Make sure assembly is level then secure with 2 (H1) Hex Bolts (with lock washer, flat washer and t-nut) per side. (fig. 35.4)

C: Tighten the top screws in all 4 Bench Legs. (fig. 35.4)

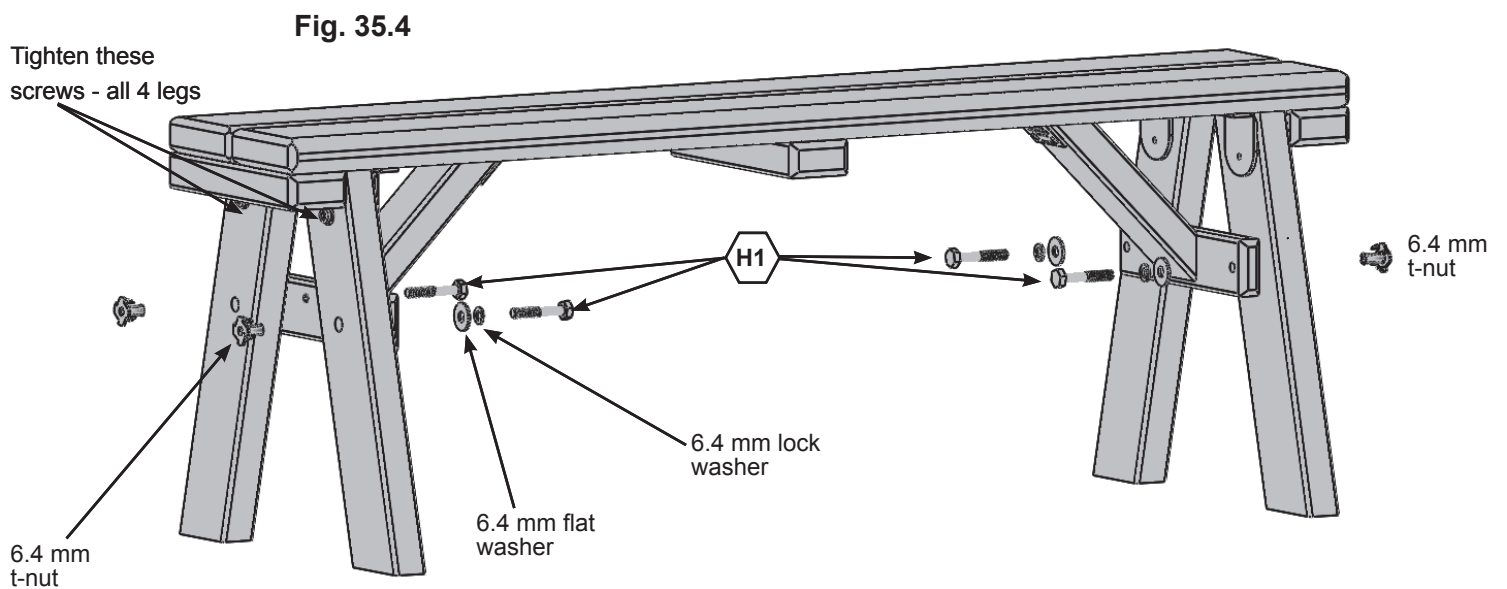
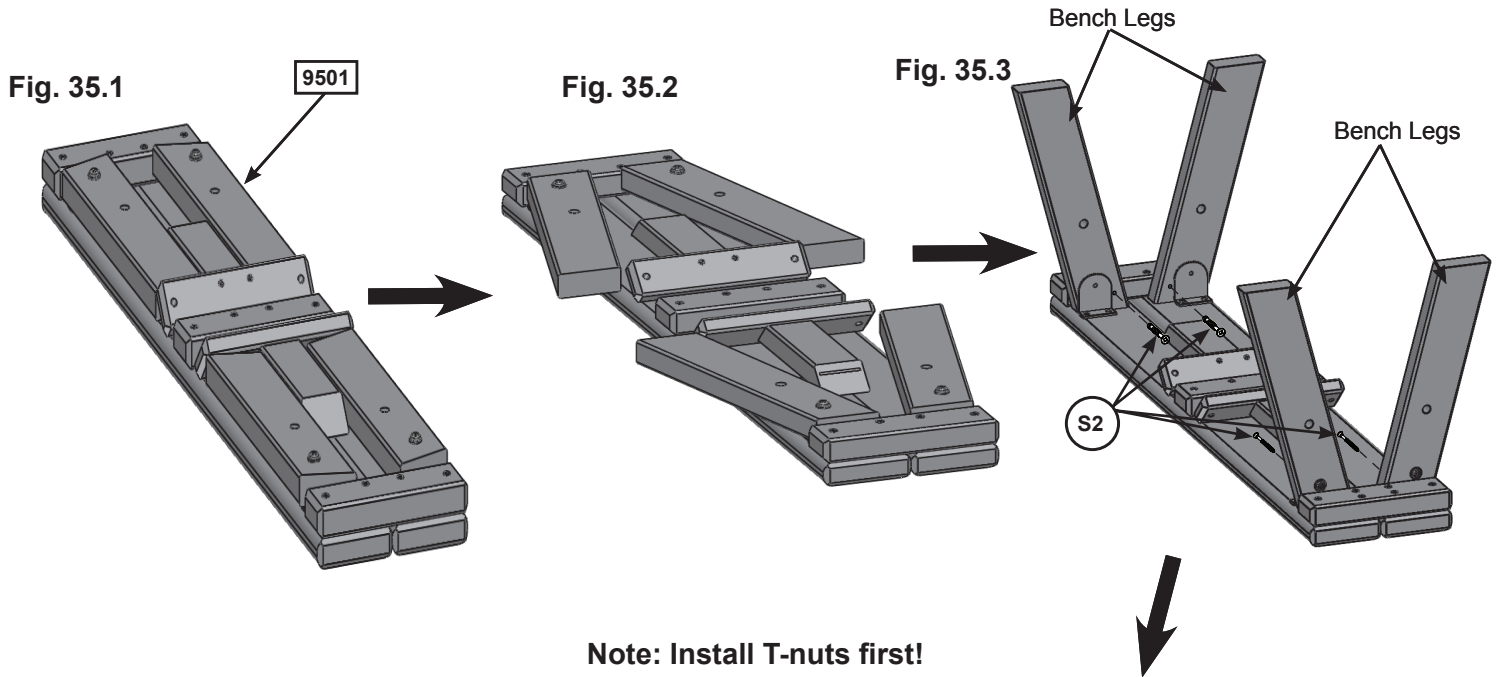

Wood Parts

1 x 9501 Folding Bench

Hardware

4 x H1 6.4 x 38.1mm Hex Bolt
(6.4 mm lock washer, 6.4 mm flat washer, 6.4 mm t-nut)

4 x S2 #8 x 38.1mm Wood Screw

Step 36: Glider Assembly

A: Attach 1 Space Glider Handle to the Space Glider Body using 1 (G25) Hex Bolt (with 2 flat washers and 1 lock nut). Repeat for the second Space Glider Handle. (fig. 36.1)

B: Install 2 Glider Rope into each Space Glider Handle using 2 (7.9 mm) Flat Washers and 1 Lock Nut per rope. (fig. 36.1)

Fig. 36.1

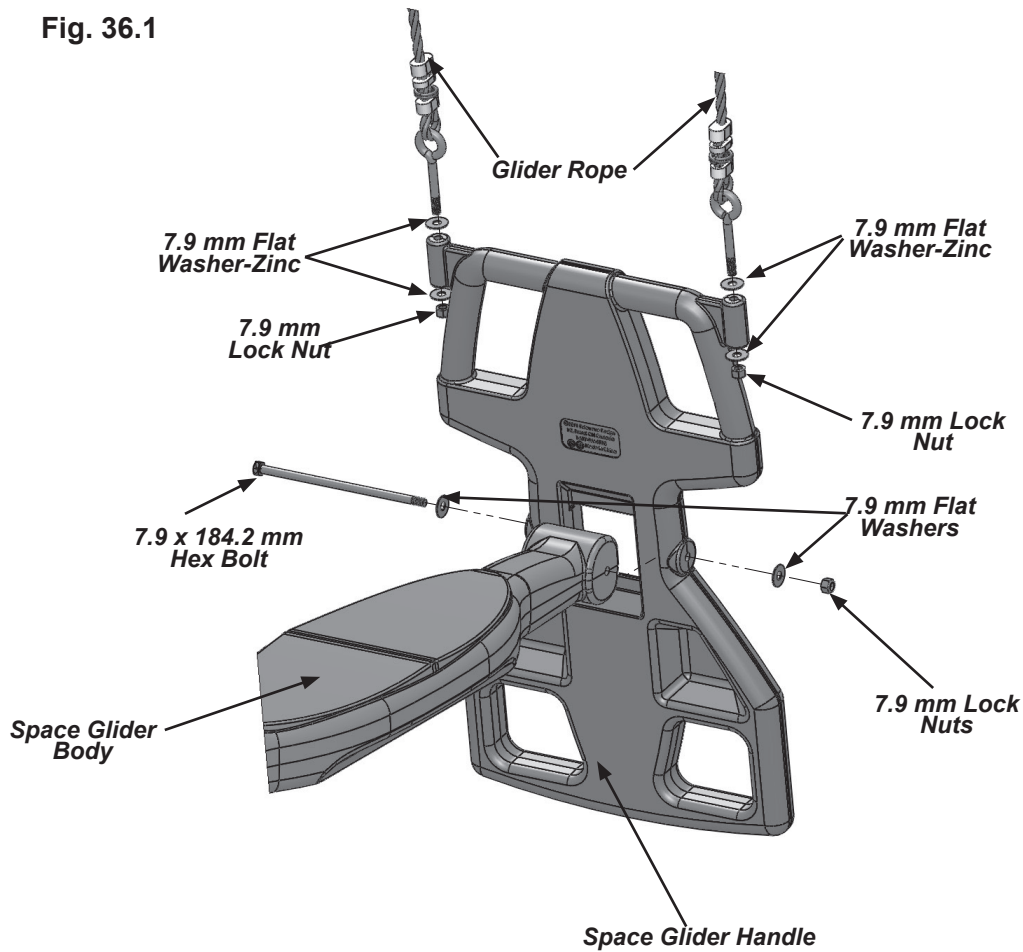

Warning! Bolt must not exceed 1/2 thread past the nut

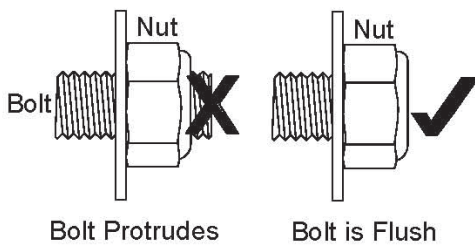

Hardware

- 2 x  7.9 x 184.2mm Hex Bolt
(7.9 mm flat washer x 2, 7.9 mm lock nut)
- 8 x 7.9 mm Flat Washer
- 4 x 7.9 mm Lock Nut

Other Parts

- 2 x Space Glider Handle
- 1 x Space Glider Body
- 1 x Glider Rope (pkg of 4)

Step 37: Attach Belt Swings and Glider

Warning! Check entire play centre for bolts protruding beyond t-nuts. Use extra washers to eliminate this condition.

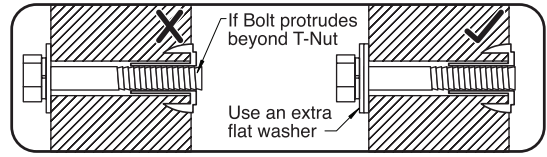

A: Attach 2 Belt Swings and assembled Space Glider to the hangers then tighten all Quick Links with an adjustable wrench. (fig. 37.1 and 37.2)

Fig. 37.1

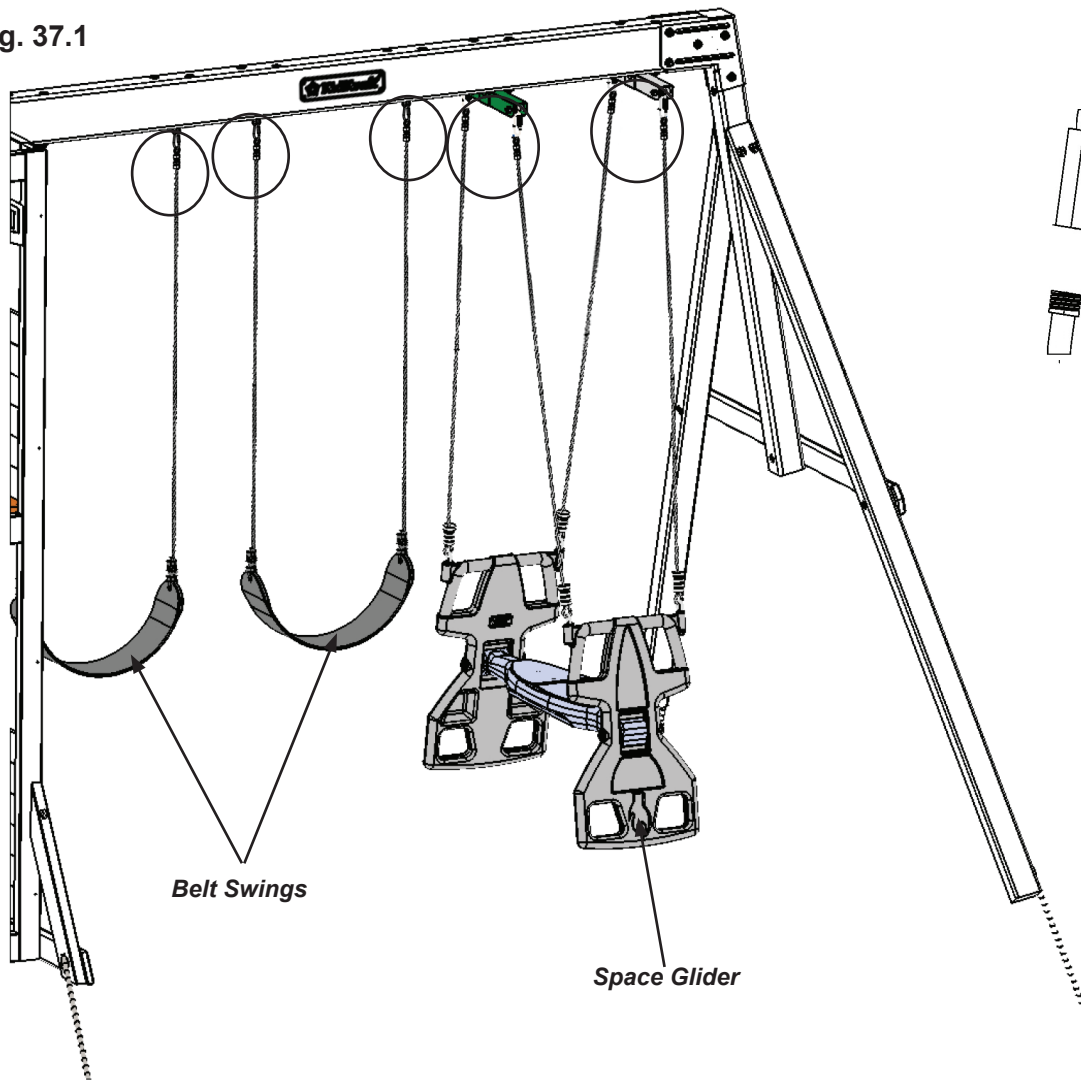
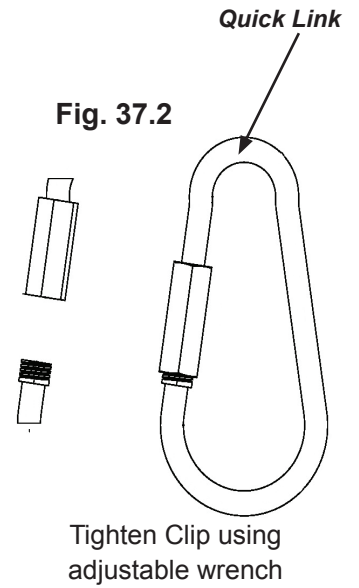

Fig. 37.2



Other Parts
2 x Belt Swings

Step 38: Attach Window Mesh - Large

Part 1

A: From inside the assembly place the Window Mesh - Large over the upper opening in the Swing Wall, make sure the mesh is smooth and tight then attach all four corners to (2627) SW Wall Panel with 4 (S5) Pan Screws (with #8 flat washers). (fig. 38.1)

Fig. 38.1

Inside View

Swing Wall

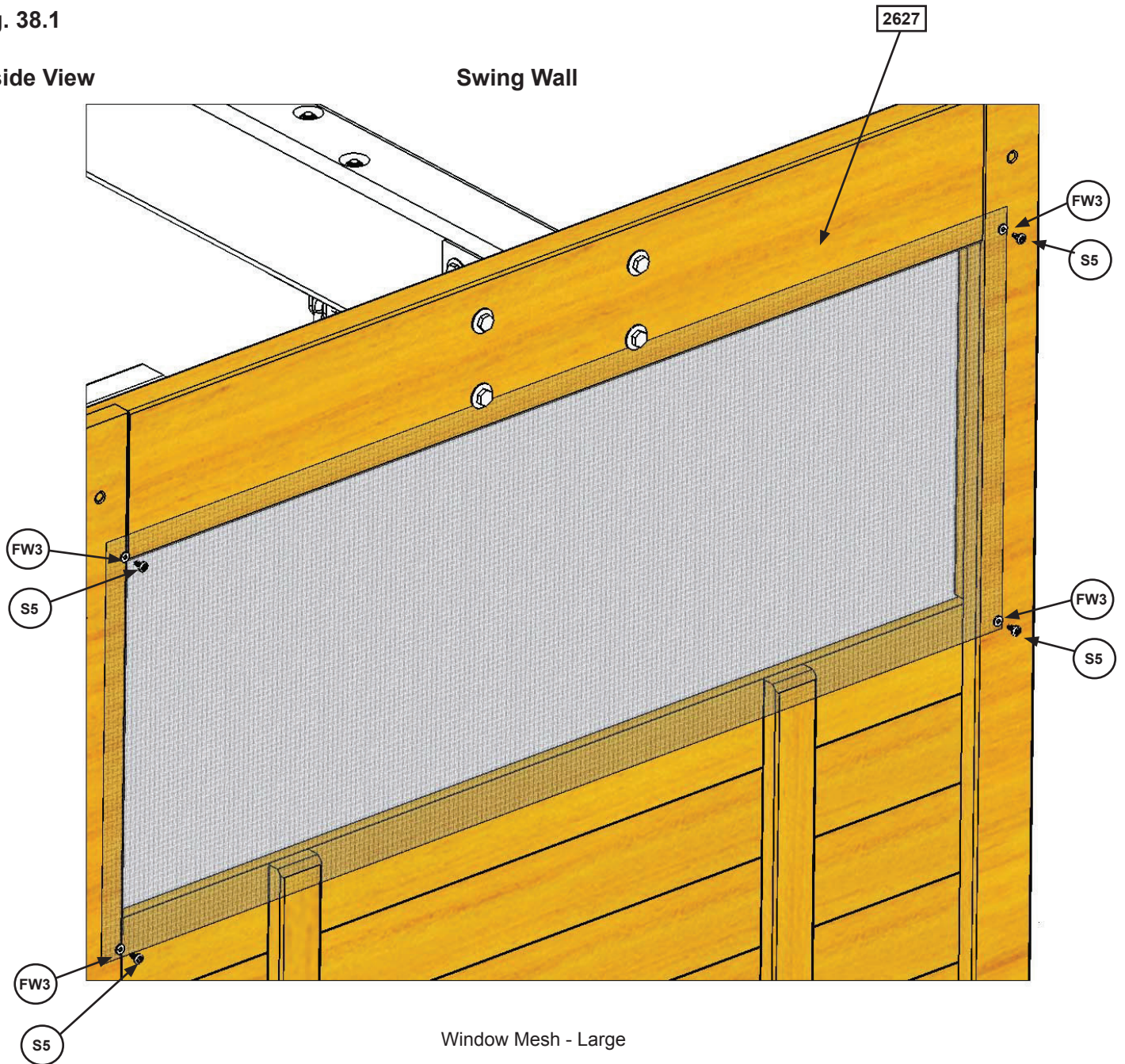

Window Mesh - Large

Hardware

4 x (S5) #8 x 12.7mm Pan Screw (#8 Flat Washer)

Other Parts

1 x Window Mesh Large

Step 38: Attach Window Mesh - Large



Part 2

B: Along each side measure 114 mm down from the top screws and the same dimension up from the bottom screws then attach 2 (S5) Pan Screws (with #8 flat washer) per side to (2627) SW Wall Panel. (fig. 38.2)

C: Along the top and bottom measure 162 mm in from the corner screws on one side then attach 5 (S5) Pan Screws (with #8 flat washer) to (2627) SW Wall Panel. Each screw to be the same dimension apart. (fig. 38.2)

Fig. 38.2

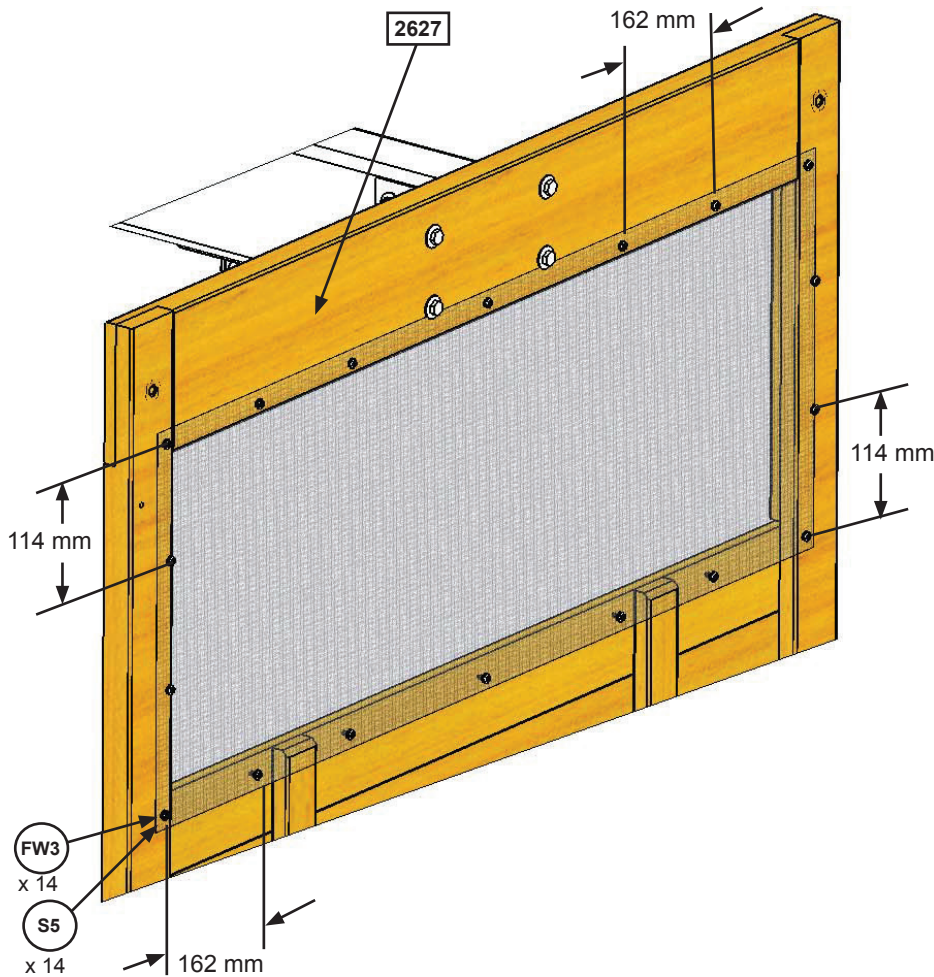

Hardware

14 x  #8 x 12.7mm Pan Screw (#8 Flat Washer)

Final Step: Attach I.D. Plaque

ATTACH THIS WARNING & I.D. PLAQUE TO THIS LOCATION ON YOUR PLAY EQUIPMENT!

A Tracking Number is provided to allow you to get critical information or order replacement parts for this specific model.

A: Attach KidKraft I.D. Plaque to a location on your set that is easily seen and read by a supervising adult using 2 (S5) Pan Screws as shown below.

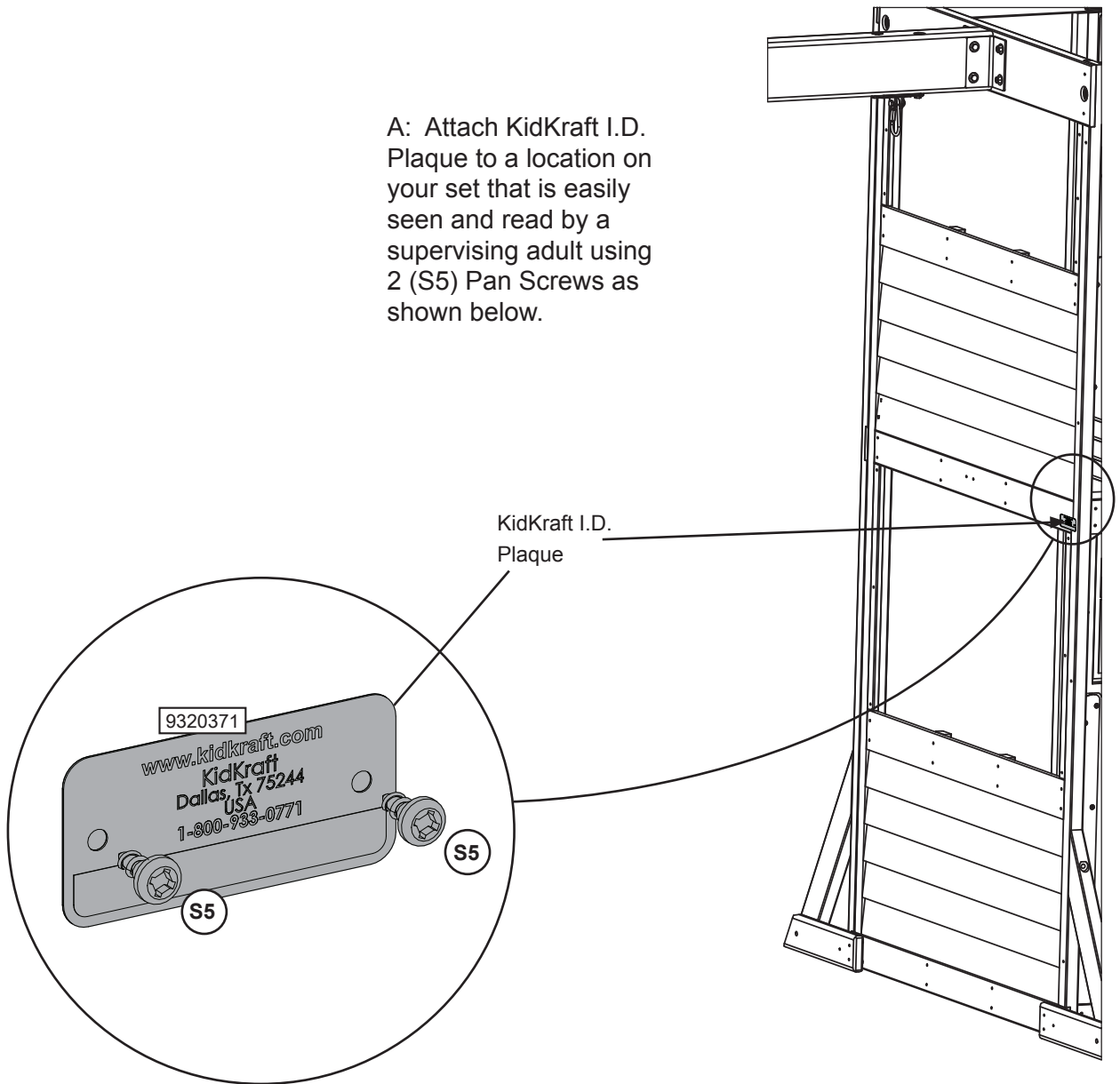

Hardware

2 x (S5) #8 x 12.7mm Pan Screw

Other Parts

1 x KidKraft I.D. Plaque

3 EASY WAYS TO REGISTER YOUR PRODUCT 24/7

- 1) Scan this QR Code with your smart phone to complete your product registration directly from your phone:
- 2) Complete the registration online at: https://www.kidkraft.com/us_en/warranty/
- 3) Mail this completed form to: KidKraft Inc., 4630 Olin Road, Dallas, Tx 75244 USA
Make sure to include a copy of your proof of purchase



KIDKRAFT Consumer Registration Card

First Name Initial Last Name

Street Apt. No.

City State/Province ZIP/Postal Code

Country Telephone Number

E-Mail Address

Model Number Model Name

Model Number & Name example
F24145 AINSLEY PLAY SYSTEM

Purchased From Date Purchase

ID Plaque example



Serial Number (on ID Plaque)

MM / DD / YY

Box #: _____ 1 of _____	Box #: _____ 4 of _____	Box # (Ex: B29410 1of 6) 1 OF 6 DE ITEM / ARTICLE N° N° DE ARTICULO B29410
Box #: _____ 2 of _____	Box #: _____ 5 of _____	
Box #: _____ 3 of _____	Box #: _____ 6 of _____	

For common questions or for information on ordering replacement parts:

Help Center: <https://kidkraft.zendesk.com/hc/en-us/>

