



Novus CLU

Monitor Arm Series

CLU

The Perfect View for What You Do

Gas Spring

Adjustable counterbalance for effortless vertical movement

Ergonomic

Easily change distance, angle, & monitor orientation



German Engineered

Guaranteed quality & durability

Viewing Angle

Easily adjust your view for touchscreen and reading.





CLU- Single Monitor Arms

Adjustable Comfort

Novus CLU Monitor Arms easily glide, turn, and tilt into any view that's perfect for what you do. Designed with your comfort in mind, these monitor arms move seamlessly into an personalized viewing position.

More Space

Create more space by lifting technology off your desk. These space-saving arms elevate monitors effortlessly, hide cables, and can be hidden behind the monitor for an organized appearance.

Durable

Aluminum construction with gas spring adjustability provides effortless vertical movement. These monitor arms are German engineered and held to the highest standards for quality and durability.



Smooth Rotation: Monitor rotation for landscape or portrait viewing.



Easy Alignment: Gas spring movement and flexible joints for perfect monitor alignment.

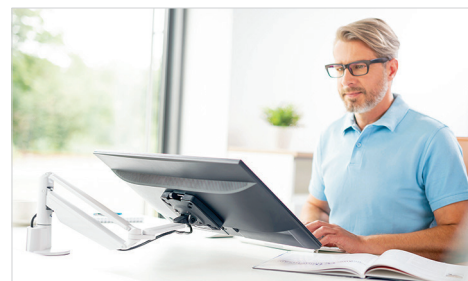

Optimal Positioning: Lift, turn, and tilt to find your perfect viewing position.

Novus CLU I

Designed to enhance comfort by elevating a monitor to its ideal viewing position.

- Enhances comfort and improves ergonomics with custom-fit adjustability
- Provides more space by elevating a monitor above the work surface
- Smooth joint movement for easily changing distance, angle, and rotation
- Gas spring provides effortless vertical movement
- Arm conceals behind the monitor and hides cables for a clean look
- German engineered with aluminum construction for quality and durability
- Quick release connection makes it easy to relocate or upgrade monitors
- Monitor arm weight capacity up to 15.4 pounds



CLU I

Item Number	Color	Base Mount
990+1011+000	White	3-in-1 Mount
990+1018+000	Black	3-in-1 Mount
990+1019+000	Silver	3-in-1 Mount



CLU I (no mount)

Item Number	Color	Base Mount
990+1001+000	White	Not Included
990+1008+000	Black	Not Included
990+1009+000	Silver	Not Included



CLU I (Slatwall mount)

Item Number	Color	Base Mount
990+1071+000	White	Slatwall
990+1079+000	Silver	Slatwall

Novus CLU II

Designed with a taller, longer profile to elevate and position a larger monitor.

- Enhances comfort and improves ergonomics with custom-fit adjustability
- Provides more space by elevating a monitor above the work surface
- Smooth joint movement for easily changing distance, angle, and rotation
- Gas spring provides effortless vertical movement
- Arm conceals behind the monitor and hides cables for a clean look
- German engineered with aluminum construction for quality and durability
- Quick release connection makes it easy to relocate or upgrade monitors
- Monitor arm weight capacity up to 15.4 pounds



CLU II

Item Number	Color	Base Mount
990+2011+000	White	3-in-1 Mount
990+2018+000	Black	3-in-1 Mount
990+2019+000	Silver	3-in-1 Mount



CLU II (no mount)

Item Number	Color	Base Mount
990+2001+000	White	Not Included
990+2008+000	Black	Not Included
990+2009+000	Silver	Not Included

Novus CLU III

Designed to easily move into a very low position - ideal for touch screen use.

- Enhances comfort and improves ergonomics with custom-fit adjustability
- Provides more space by elevating a monitor above the work surface
- Smooth joint movement for easily changing distance, angle, and rotation
- Gas spring provides effortless vertical movement
- Arm conceals behind the monitor and hides cables for a clean look
- German engineered with aluminum construction for quality and durability
- Quick release connection makes it easy to relocate or upgrade monitors
- Monitor arm weight capacity up to 15.4 pounds



CLU III

Item Number	Color	Base Mount
990+3011+000	White	3-in-1 Mount
990+3018+000	Black	3-in-1 Mount
990+3019+000	Silver	3-in-1 Mount



CLU III (no mount)

Item Number	Color	Base Mount
990+3001+000	White	Not Included
990+3008+000	Black	Not Included
990+3009+000	Silver	Not Included

Novus CLU Plus

Designed to support large monitors and curved screens up to 40".

- Enhances comfort and improves ergonomics with custom-fit adjustability
- Provides more space by elevating a monitor above the work surface
- Smooth joint movement for easily changing distance, angle, and rotation
- Heavy-duty gas spring for effortless vertical movement
- Arm conceals behind the monitor and hides cables for a clean look
- German engineered with aluminum construction for quality and durability
- Quick release connection makes it easy to relocate or upgrade monitors
- Monitor arm weight capacity up to 33 pounds



CLU Plus

Item Number	Color	Base Mount
991+3011+000	White	3-in-1 Mount
991+3018+000	Black	3-in-1 Mount
991+3019+000	Silver	3-in-1 Mount



CLU Plus (no mount)

Item Number	Color	Base Mount
991+3001+000	White	Not Included
991+3008+000	Black	Not Included
991+3009+000	Silver	Not Included



CLU- Multi Monitor Arms

Novus CLU Duo

Designed for easy alignment of two monitors for comfortable side-by-side viewing.

- Enhances comfort and improves ergonomics with custom-fit adjustability
- Provides more space by elevating two monitors above the work surface
- Smooth joint movement for easily changing distance, angle, and rotation
- Heavy-duty gas spring provides effortless vertical movement
- Arm conceals behind the monitor and hides cables for a clean look
- German engineered with aluminum construction for quality and durability
- Quick release connection makes it easy to relocate or upgrade monitors
- Monitor arm weight capacity up to 15.4 pounds per arm

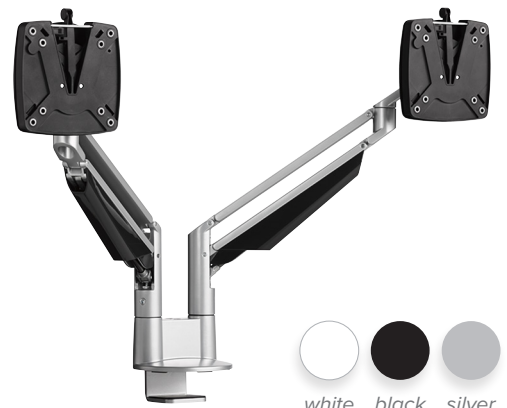

CLU Duo

Item Number	Color	Base Mount
990+4011+000	White	3-in-1 Mount
990+4018+000	Black	3-in-1 Mount
990+4019+000	Silver	3-in-1 Mount

Novus CLU X2

Designed to elevate two monitors and keep them in perfect alignment.

- Enhances comfort and improves ergonomics with custom-fit adjustability
- Provides more space by elevating two monitors above the work surface
- Smooth joint movement for easily changing distance, angle, and rotation
- Heavy-duty gas spring provides effortless vertical movement
- Arm conceals behind the monitor and hides cables for a clean look
- German engineered with aluminum construction for quality and durability
- Quick release connection makes it easy to relocate or upgrade monitors
- Monitor arm weight capacity up to 30 pounds



CLU Plus X2

Item Number	Color	Base Mount
992+2011+000	White	3-in-1 Mount
992+2018+000	Black	3-in-1 Mount
992+2019+000	Silver	3-in-1 Mount



CLU Plus X2 (no mount)

Item Number	Color	Base Mount
992+2001+000	White	Not Included
992+2008+000	Black	Not Included
992+2009+000	Silver	Not Included

Novus CLU X3

Designed to elevate three monitors and keep them in perfect alignment.

- Enhances comfort and improves ergonomics with custom-fit adjustability
- Provides more space by elevating three monitors above the work surface
- Smooth joint movement for easily changing distance, angle, and rotation
- Heavy-duty gas spring provides effortless vertical movement
- Arm conceals behind the monitor and hides cables for a clean look
- German engineered with aluminum construction for quality and durability
- Quick release connection makes it easy to relocate or upgrade monitors
- Monitor arm weight capacity up to 30 pounds



CLU Plus X3

Item Number	Color	Base Mount
993+2011+000	White	3-in-1 Mount
993+2018+000	Black	3-in-1 Mount
993+2019+000	Silver	3-in-1 Mount



CLU Plus X3 (no mount)

Item Number	Color	Base Mount
993+2001+000	White	Not Included
993+2008+000	Black	Not Included
993+2009+000	Silver	Not Included



Designed with your comfort in mind, Novus CLU Monitor Arms glide seamlessly into the perfect viewing position.

Base Mount Options



3-in-1 Mount

Item Number	Fits	Color
898+0011+000	CLU	White
898+0018+000	CLU	Black
898+0019+000	CLU	Silver
899+0011+000	CLU Plus	White
899+0018+000	CLU Plus	Black
899+0019+000	CLU Plus	Silver



Rail Mount

Item Number	Fits	Color
898+0061+000	CLU	White
898+0068+000	CLU	Black
898+0069+000	CLU	Silver
899+0061+000	CLU Plus	White
899+0068+000	CLU Plus	Black
899+0069+000	CLU Plus	Silver



Column Mount

Item Number	Fits	Color
898+0091+000	CLU	White
898+0098+000	CLU	Black
898+0099+000	CLU	Silver
899+0091+000	CLU Plus	White
899+0098+000	CLU Plus	Black
899+0099+000	CLU Plus	Silver

NOVUS[®]

Dahle North America, Inc.
49 Vose Farm Road
Peterborough, NH 03458
Tel. (800) 995-1379
info@novusmorespace.com



www.novusmorespace.com