

4-Gallon Square Container with EZ Cover®

Multiple Uses

Dry Products

Product Codes

Container: **S048**

Description: 4-gallon square can

Cover: **STDR**

Description: Tamper-evident, square EZ Cover® with Ring Pull™

Features

- Built in hand grips
- Gauge: 80 mil.
- Nominal capacity: 4.0 USG / 15.0 L
- Stack performance: 240 lbs.*
- Tare weights: Body: 1.62 lbs. / .73 kgs.
- Cover: .37 lbs. / .17 kgs.

Note: *Ratings will be reduced with uneven load distribution.

Specifications with Cover

- Dimensions: 9-15/16" X 9-15/16" X 13-1/4"H
- Maximum capacity: 4.1 USG / 15.5 L
- Tare weight: 1.99 lbs. / .90 kgs.

Colors

- Standard: White, Black and Natural
- Custom: Available at manufacturer's discretion

Decorating Options

- Silk-Screen: 5"L X 7-1/2"H
- Four or six* color offset printing
- Print area: 5"W X 8"H on each panel
- Wraparound print area: 32.4"W X 8"H
- Sleeve or pressure sensitive labeling

Note: *Where available

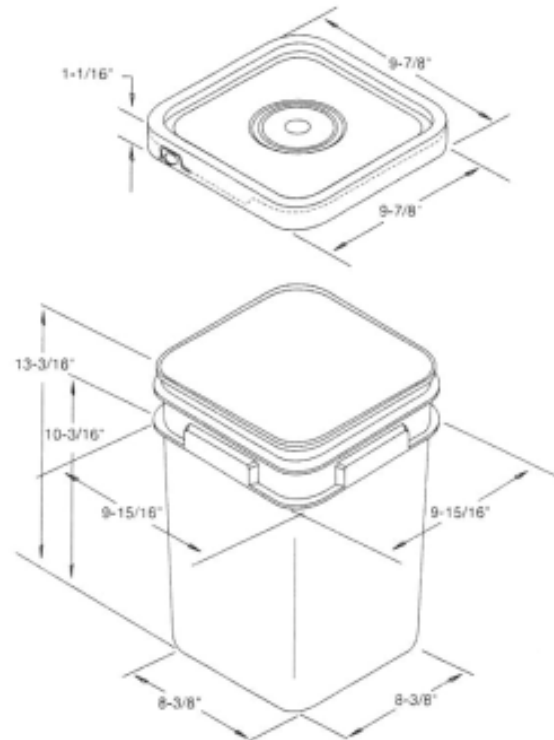

Shipping Data

	Bodies	Covers	Filled Containers
Qty. per pallet:	280	2,304 (24 boxes of 96)*	60 (20 per layer / 3 layers high)
Gross Weight (lbs./kgs.)**:	453.6/204.4	852.5/391.7	Pallet height: 44"
Den. (lbs./C.F./kgs./m3):	7.4/118.2	8.0/129.9	
Length (in./cm.):	52.5/133.4	51/129.5	
Width (in./cm.):	41/104.1	41/104.1	
Height (in./cm.):	49/124.5	89/223.6	
Estimated truckload quantity of 12,320 bodies and covers***			

Notes: *Bulk pack also available

**Weight does not include pallet / packaging

***Truckload quantity based on 53' trailer

Materials

- FDA approved materials
- Resin: Body: High-Density Polyethylene (HDPE)
- Cover: High-Density Polyethylene (HDPE)
- MSDS Sheets available upon request

Optional carrying handles

DISCLAIMER
THIS INFORMATION IS PROVIDED AS A GENERAL GUIDE, INCLUDING DIMENSIONS. IT IS THE CUSTOMER'S RESPONSIBILITIES TO SELECT THE PROPER CONTAINER FOR PRODUCT AND APPLICATION COMPATIBILITY.

DISTRIBUTED BY:



REF NO.:

DWG30565

DESCRIPTION:

HDPE Square Tear Tab Cover for 4 Gallon Pails (No Gasket)