

# ONE COLLECT. HOME OFFICE CHAIR ASSEMBLY INSTRUCTIONS

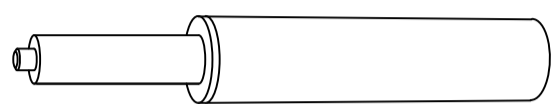

## PARTS PACKING CONFIGURATIONS

A. LIFT CYLINDER 1PC



B. LEG 1PC

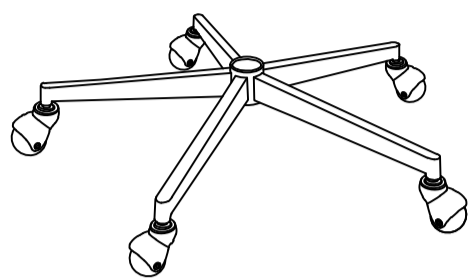

C. CONTROL MECHANISM 1PC

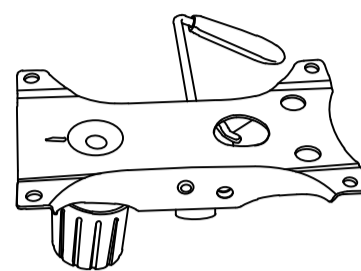

D. SEAT 1PC

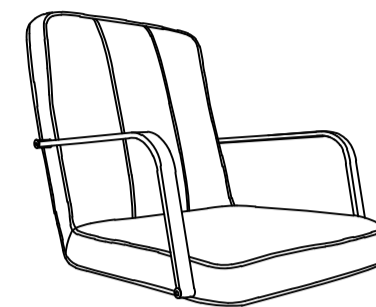

### HARDWARE KIT PACKED IN BOX

NO.	DESCRIPTION	IMAGE	Q'TY
1	ALLEN BOLT (M6x20mm)		2 PCS
2	ALLEN BOLT (M6x30mm)		2 PCS
3	SPRING WASHER (M6)		4 PCS
4	FLAT WASHER (M6)		4 PCS
5	ALLEN KEY (M4)		1 PC
6	ALLEN KEY (M5)		1 PC

### FULLY ASSEMBLED

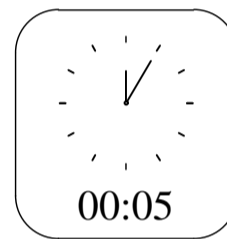
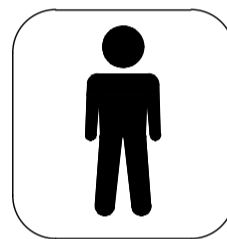

STEP 1:

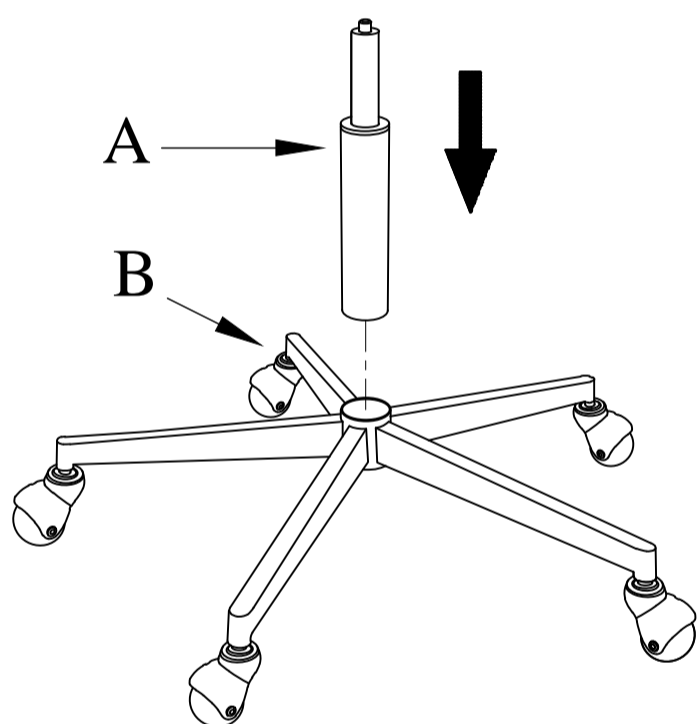

STEP 2:

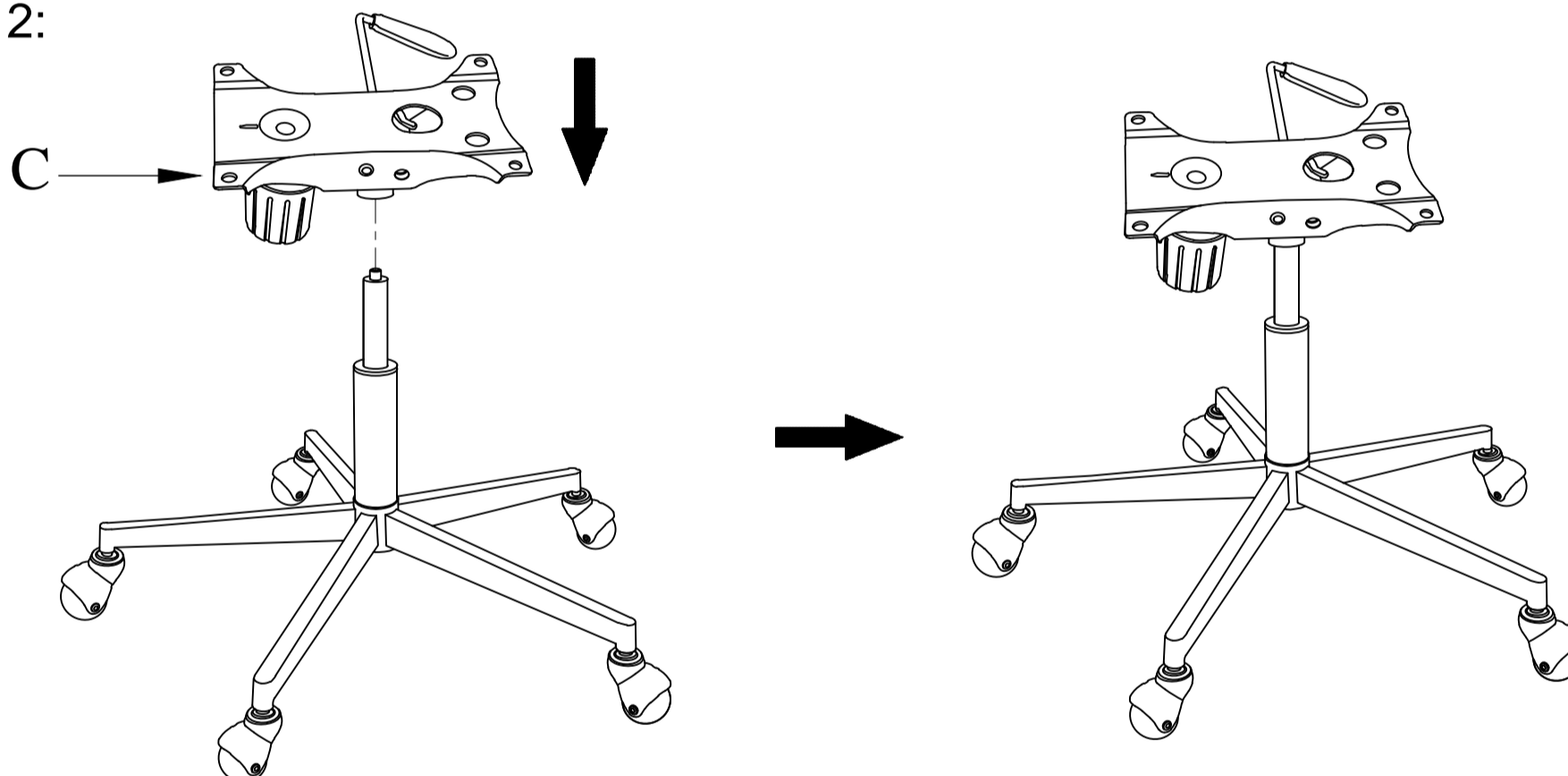

STEP 3:

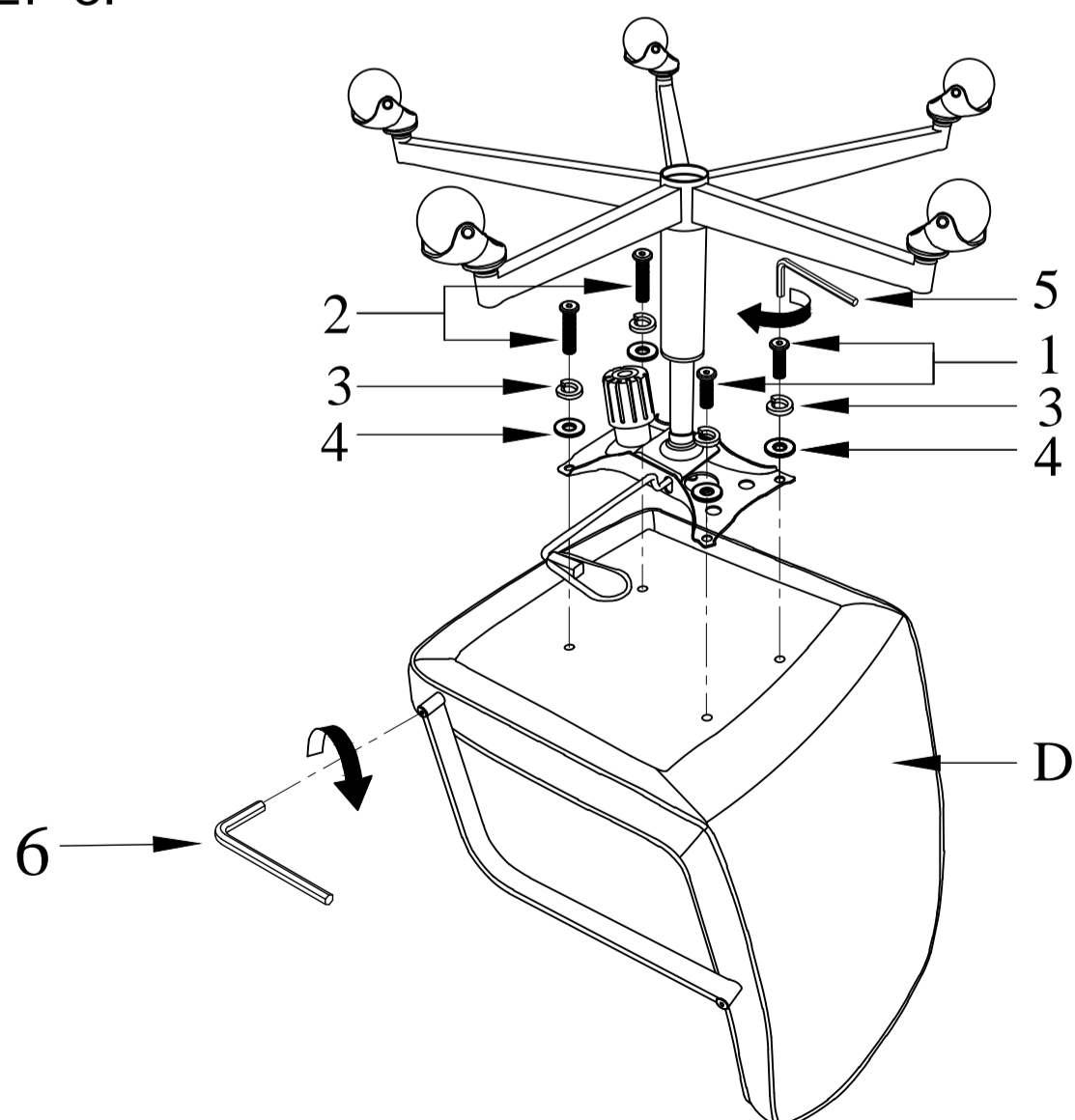

NOTE: Position body at backmost of seat to operate the lift mechanism.

ASSEMBLY COMPLETE

