

# Product Specifications

## 1-Gallon Lightweight Polypropylene Round Container with FIG EZ Cover®

### Multiple Uses

Dry Products  
Liquid Products

### Product Codes

Container: **R014**  
Description: 1-gallon round can

### Cover: T1FZ

Description: Tamper-evident, round EZ Cover® flowed-in gasket

### Features

Gauge: 40 mil.  
Nominal capacity: 1 USG / 3.8 L  
Stack performance: 150 lbs.\*  
Tare weights: Body: .313 lbs. / .142 kgs.  
Cover: .20 lbs. / .09 kgs.

Note: \*Ratings will be reduced with uneven load distribution.

### Specifications with Cover

Dimensions: 8-1/4"D X 7-5/16"H  
Maximum capacity: 1.1 USG / 4.2 L  
Tare weight: .513 lbs. / .232 kgs.

### Colors

Standard: White, Black and Natural  
Custom: Available at manufacturer's discretion

### Decorating Options

Silk - Screening: 20-3/4"W X 4-1/2"H  
Four or six\* color offset printing  
Print area: 22-3/4"W X 4-1/2"H  
Sleeve or pressure sensitive labeling

Note: \*Where available

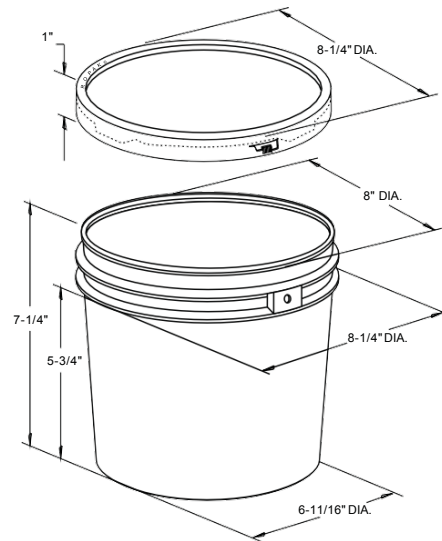

### Shipping Data

	<b>Bodies</b>	<b>Covers</b>
Qty. per pallet:	450	3,000 (20 boxes of 150)
Gross Weight (lbs./kgs.):*	140.9/63.9	600/270
Den. (lbs./C.F./kgs./m3):	4.1/66	6.5/103.1
Length (in./cm.):	49.5/125.7	50.5/128.3
Width (in./cm.):	41.3/104.9	42.5/107.9
Height (in./cm.):	29/73.7	74.5/189.2

Estimated truckload quantity of 25,650 bodies and covers\*\*

Notes: \*Weight does not include pallet/packaging  
\*\*Truckload quantity based on 53' trailer

### Filled Containers

180 (30 per layer/6 layers high)  
Pallet height: 48"

### Materials

FDA approved materials  
Resin: Body: Polypropylene (PP)  
Cover: High-Density Polyethylene (HDPE)  
Hot Melt Synthetic Resin – Flowed-in Gasket  
MSDS Sheets available upon request

### Optional Carrying Handle

**DISCLAIMER**  
THIS INFORMATION IS PROVIDED AS A GENERAL GUIDE, INCLUDING DIMENSIONS. IT IS THE CUSTOMER'S RESPONSIBILITIES TO SELECT THE PROPER CONTAINER FOR PRODUCT AND APPLICATION COMPATIBILITY.

DISTRIBUTED BY:



REF NO.:

DWG30569

DESCRIPTION:

1 gallon HDPE Open Head Pail