

Trusted. Tested. Tough.®

Product information presented here reflects conditions at time of publication. Consult factory regarding discrepancies or inconsistencies.



SECTION: 2.65.078
FM3344
0521
Supersedes
New

U.S. Patent Pending

TECHNICAL DATA SHEET

Qwik Jon®

PREMIER

Model 201

PRODUCT SPECIFICATIONS

MOTOR	Horse Power	1/2
	Voltage	115
	Phase	1 Ph
	Hertz	60 Hz
	RPM	3450
	Type	Permanent split capacitor
	Insulation	Class B
	Amps	9.6
PUMP	Operation	Automatic
	Discharge Size	1"
	Solids Handling	Grinder
	Cord Length	6' (1.8 m) standard
	Cord Type	UL listed neoprene cord and plug
	Certification	cCSAus
	Max. Head	29.5' (9m)
	Max. Flow Rate	45 GPM (170 LPM)
	Max. Operating Temp.	130°F (54°C)
	Cooling	Oil filled
Motor Protection	Auto reset thermal overload	
MATERIALS	Cap	Engineered plastic
	Motor Housing	Cast iron
	Pump Housing	Engineered plastic
	Tank	ABS
	Upper Bearing	Ball bearing
	Lower Bearing	Ball bearing
	Mechanical Seals	Carbon/ceramic
	Impeller Type	Non-clogging vortex
	Impeller	Engineered plastic
	Hardware	Stainless steel
	Motor Shaft	AISI 1215
	Tank Seal	Buna N

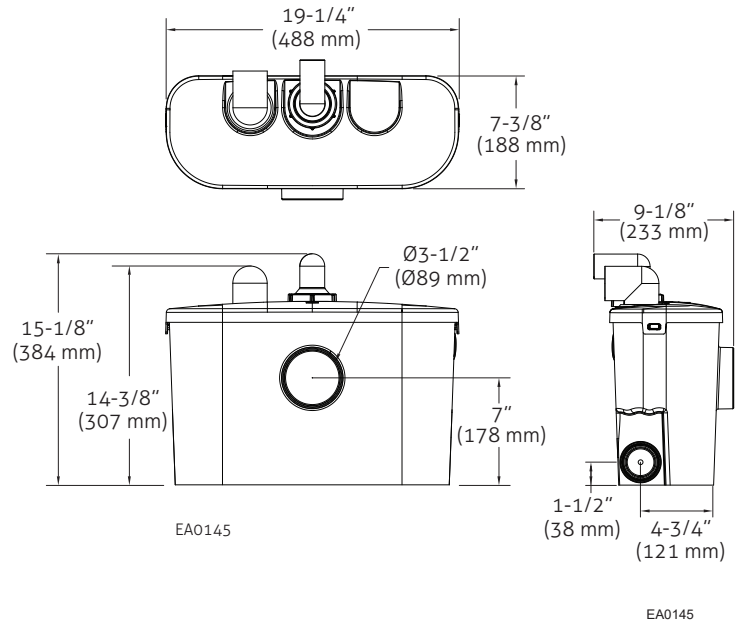

TOTAL DYNAMIC HEAD FLOW PER MINUTE

TOTAL DYNAMIC HEAD/FLOW			
MODEL		115V/60Hz	
Feet	Meters	Gallons	Liters
5	1.5	45	170.3
10	3.0	39	147.6
15	4.6	33	124.9
20	6.1	25	94.6
25	7.6	13	49.2
Shut-off Head		29.5ft (9m)	

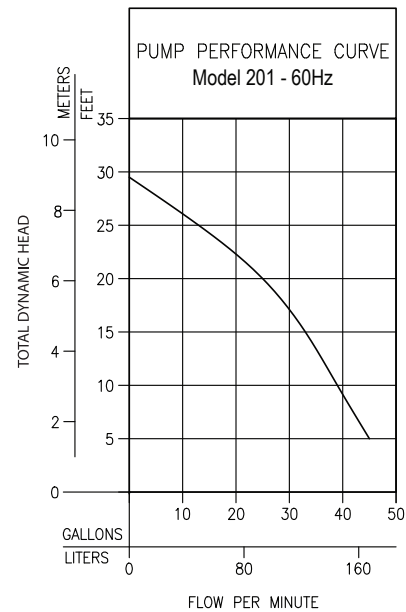

084975

Qwik Jon Premier system includes the following three items:

- (1) p/n 201-0006 Qwik Jon Premier grinder pump and tank.
- (2) p/n 202-2000 Qwik Jon elongated toilet bowl.
- (3) p/n 202-3002 Qwik Jon toilet tank and lid. An optional extension kit, p/n 10-3050 is available for recessed or behind-the-wall installations.

SPECIFICATIONS

- Discharge can be reduced from 1" (DN25) to 3/4" (DN 20) to replace existing systems
- Pumps any direction
- Shipping Weight: 31 lbs (14 kg)
- Check valve built into removable discharge elbow
- Grinder Tank: (2) 1-1/2" (DN40) slip / 2" MPT auxiliary inlets and 1-1/2" (DN40) vent.
- Premium Tri-Slice (R) Cutter Technology: Investment-cast 440 stainless steel cutter and cutter plate is engineered to handle cloth, latex, and other hard to grind materials.



ITEMS NEEDED BY INSTALLER

- Supply fittings and waste pipe
- Electrical source with ground fault interrupter (GFCI) protected receptacle
- Water supply
- Tools

OPTIONS

- Complete the installation with a 1.28 gallon (4.8 L) per flush EPA WaterSense listed, ADA compliant toilet with an elongated bowl. Order P/N 202-3002 (toilet tank) and P/N 202-2000 (toilet tank).
- Qwik Jon® extension kit, for behind-the-wall installations. P/N 10-3050*

* Not IAPMO approved.



CAUTION All installation of controls, protection devices and wiring should be done by a qualified licensed electrician. All electrical and safety codes should be followed including the most recent National Electrical Code (NEC) and the Occupational Safety and Health Act (OSHA).



Model 202 meets the Americans with Disabilities Act guidelines and ANSI A117.1 requirements for accessible and usable facilities—check local codes.