

# Product Specifications

## 2.0 Gallon UN Pail

Note: \*Rated for Solids Y7.5/S for Packing Group II and III (USA and Canada)

### Multiple Uses

Dry Products  
Liquid Products

### Product Codes

Container: **1200 Series**  
Description: 2.0 gallon 2-Ring UN pail

### Features

Gauge: 70 mil.  
Nominal capacity: 2.0 USG / 7.6 L  
Stack performance: 150 lbs.\*  
Tare weights: Body: .82 lbs. / .370 kgs

Note: \*Ratings will be reduced with uneven load distribution.

### Specifications with Cover

Dimensions: 9-7/8" D X 9-1/2"H  
Maximum capacity: 2.1 USG / 7.9 L  
Tare weight: 1.09 lbs. / .49 kgs.

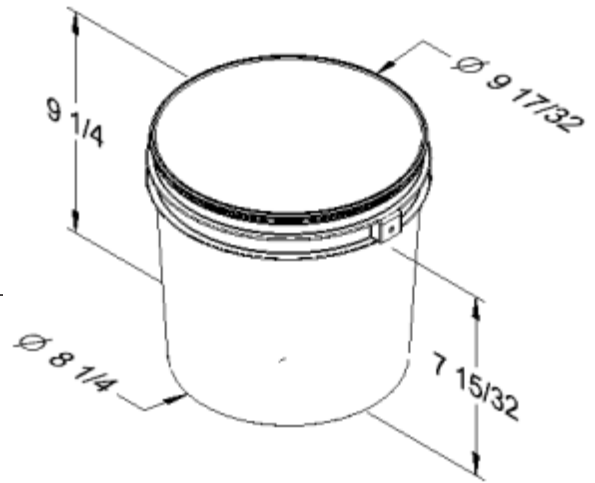

### Colors

Standard: White, Black and Natural  
Custom: Available at manufacturer's discretion

### Decorating Options

Four color offset printing  
Print area: 27"W x 5-3/4"H  
Sleeve or pressure sensitive labeling

### Shipping Data

Qty. per pallet/carton: 720\*  
Gross Weight (lbs/kgs.)\*\*: 590 / 267  
Length (in./cm.): 49 / 125  
Width (in./cm.): 39.5 / 100  
Height (in./cm.): 88 / 223.5

### Bodies

### Filled Containers

36 (12 per layer / 3 layers high)  
Pallet Height: 28-1/2"

Estimated truckload quantity of 10,800 bodies and covers\*\*\*

Notes: \*Quantity can vary based on customer request  
\*\*Weight does not include pallet/packaging  
\*\*\*Truckload quantity based on 53' trailer

### Materials

FDA approved materials  
Resin: Body: High-Density Polyethylene (HDPE)

### Optional Carrying Handle

Wire or Plastic

DISTRIBUTED BY:



REF NO.:

DWG10127

DESCRIPTION:

2 Gallon HDPE OH Pail, UN Rated

### DISCLAIMER

THIS INFORMATION IS PROVIDED AS A GENERAL GUIDE, INCLUDING DIMENSIONS. IT IS THE CUSTOMER'S RESPONSIBILITIES TO SELECT THE PROPER CONTAINER FOR PRODUCT AND APPLICATION COMPATIBILITY.