

Product Specifications

5.3-Gallon EZ STOR® Container

Multiple Uses

Dry Products

Product Codes

Container: **E538**

Description: 5.3-gallon rectangular can

Features

Built in hand grips
Gauge: 80 mil.
Nominal capacity: 5.3 USG / 20 L
Stack performance: 220 lbs.*
Tare weights: Body: 1.90 lbs. / .86 kgs.

Note: *Ratings will be reduced with uneven load distribution.

Specifications with Cover

Dimensions: 11-15/16" L X 9-7/8" W X 14-11/16" H*
Maximum capacity: 5.6 USG / 21.2 L
Tare weight: 2.29 lbs. / 1.04 kgs.

Notes: *Based on HDPE body

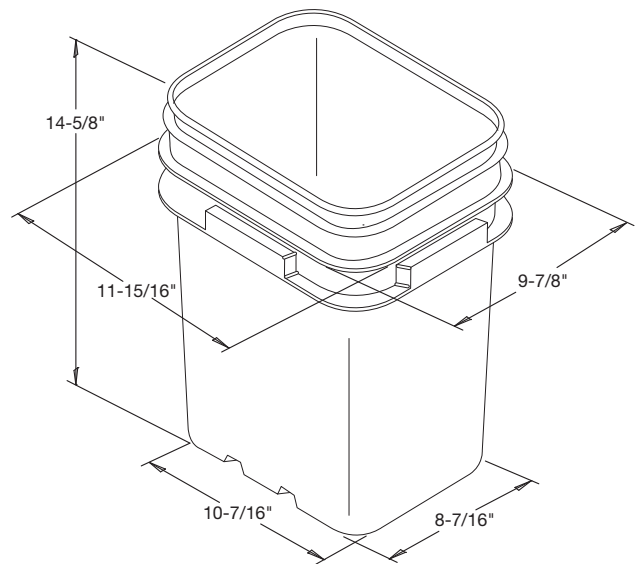

Colors

Standard: White, Black, Natural and Clear
Custom: Available at manufacturer's discretion

Decorating Options*

Four or six color offset printing**
Sleeve or pressure sensitive labeling
In-Mold labeling (IML)
NXT Graphics®

Note: *See EZ Stor Decoration Summary for further details.

**Where available.

Shipping Data

Qty. per pallet: 144
Gross Weight (lbs./kgs)*: 273.6/123.8
Den. (lbs./C.F./kgs./m3): 4.6/72.8
Length (in./cm.): 49.5/125.7
Width (in./cm.): 41/104.1
Height (in./cm.): 50.5/128.3
Estimated truckload quantity of 6,336 bodies and covers**

Bodies

Filled Containers

48 (16 per layer / 3 layer high)
Pallet height: 48.75"

Notes: *Weight does not include pallet / packaging

**Truckload quantity based on 53' trailer

Materials

FDA approved materials
Resin: Body: High Density Polyethylene (HDPE)
or Clear Polypropylene

Optional Carrying Handle

DISCLAIMER

THIS INFORMATION IS PROVIDED AS A GENERAL GUIDE, INCLUDING DIMENSIONS. IT IS THE CUSTOMER'S RESPONSIBILITIES TO SELECT THE PROPER CONTAINER FOR PRODUCT AND APPLICATION COMPATIBILITY.

DISTRIBUTED BY:



REF NO.:

DWG10153

DESCRIPTION:

5.3 Gallon HDPE EZ Stor Pail