

WALKER EDISON
™

1- Drawer Nightstand Classic Solid Wood

SKU: BR1DLYDNS
LOT: **AAYYWW-XXX**

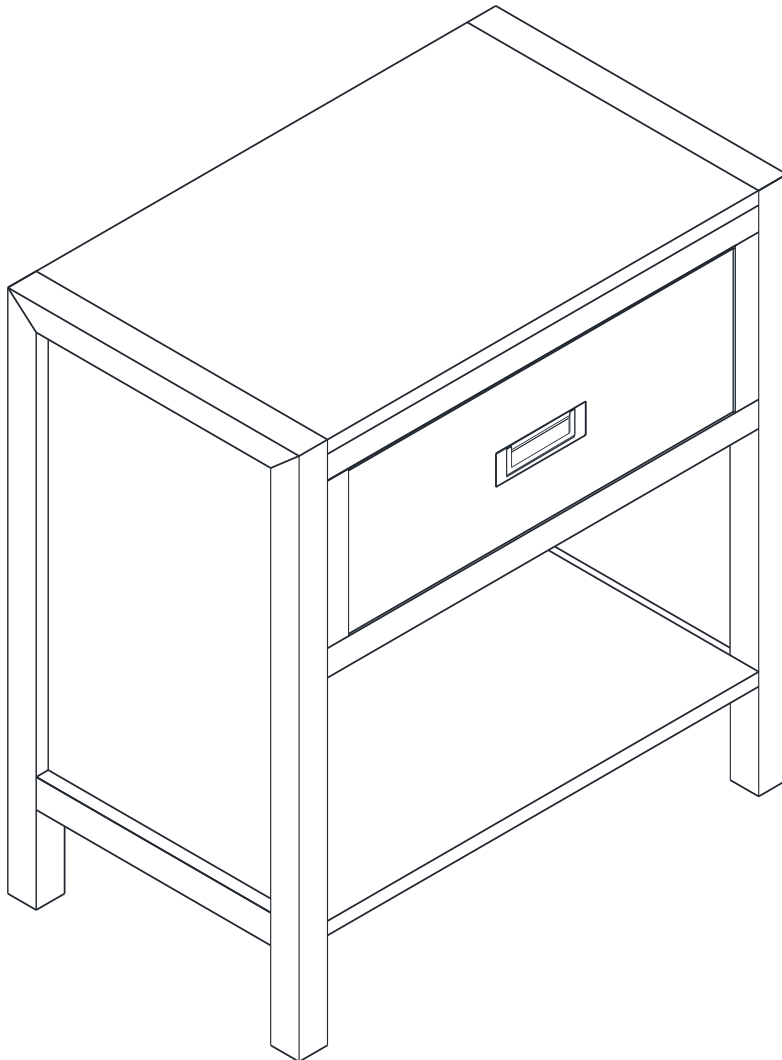

For Residential Use Only

Please visit our website for the most current instructions, assembly tips, to report damage, or request parts. www.walkeredison.com

WE Time to get started

Set up a clean and soft workplace to avoid damage during assembly. You can use the box and internal protections as a cover. It also helps to double-check if you have got all the pieces and parts before diving into the assembly.

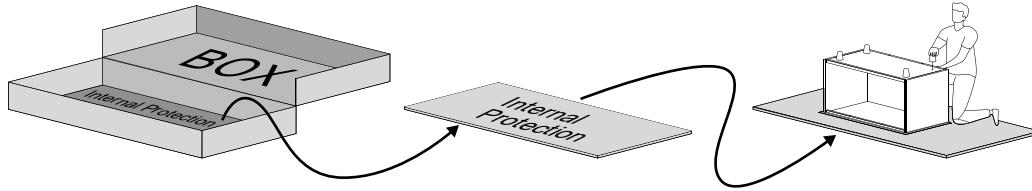

**Estimated time
for assembly**

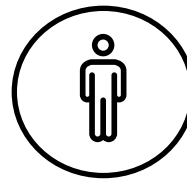

1 Person Build

**You can assemble
it alone.**

But you can make
it a team effort!
Grab a friend for quicker,
easier assembly.

Tools Needed

Grab a Phillips head screwdriver to
conquer this assembly.

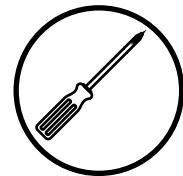

Use power tools whit caution

This furniture is made of Solid Wood and Composite Wood,
soft materials. If you choose to use power tools, set it to the
slower setting. Be careful! Power tools can cause cracking
or damage to the furniture, they can also damage the
hardware if misused. Power tool damages are not covered
by the Walker Edison warranty

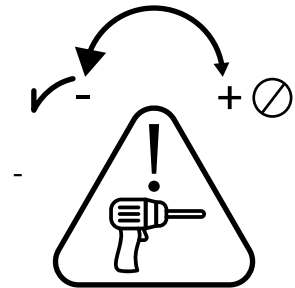

Slide care

Your furniture has highly durable wooden sliders.
From time to time we recommend applying paraffin or
standard candle wax to improve gliding of the sliders.

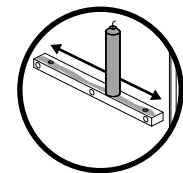

Scan to get assembly tips and help!

WE Part List

Part Number	Description	Quantity
04	Front Frame	01
11	Drawer Bottom	01
19	Drawer Front	01
20	Drawer Back	01
21	Top Panel	01
26	Bottom Panel	01

Part Number	Description	Quantity
27	Left Side Panel	01
28	Right Side Panel	01
32	Left Drawer Side	01
33	Right Drawer Side	01
35	Wood Slider	02
42	Back Panel	02







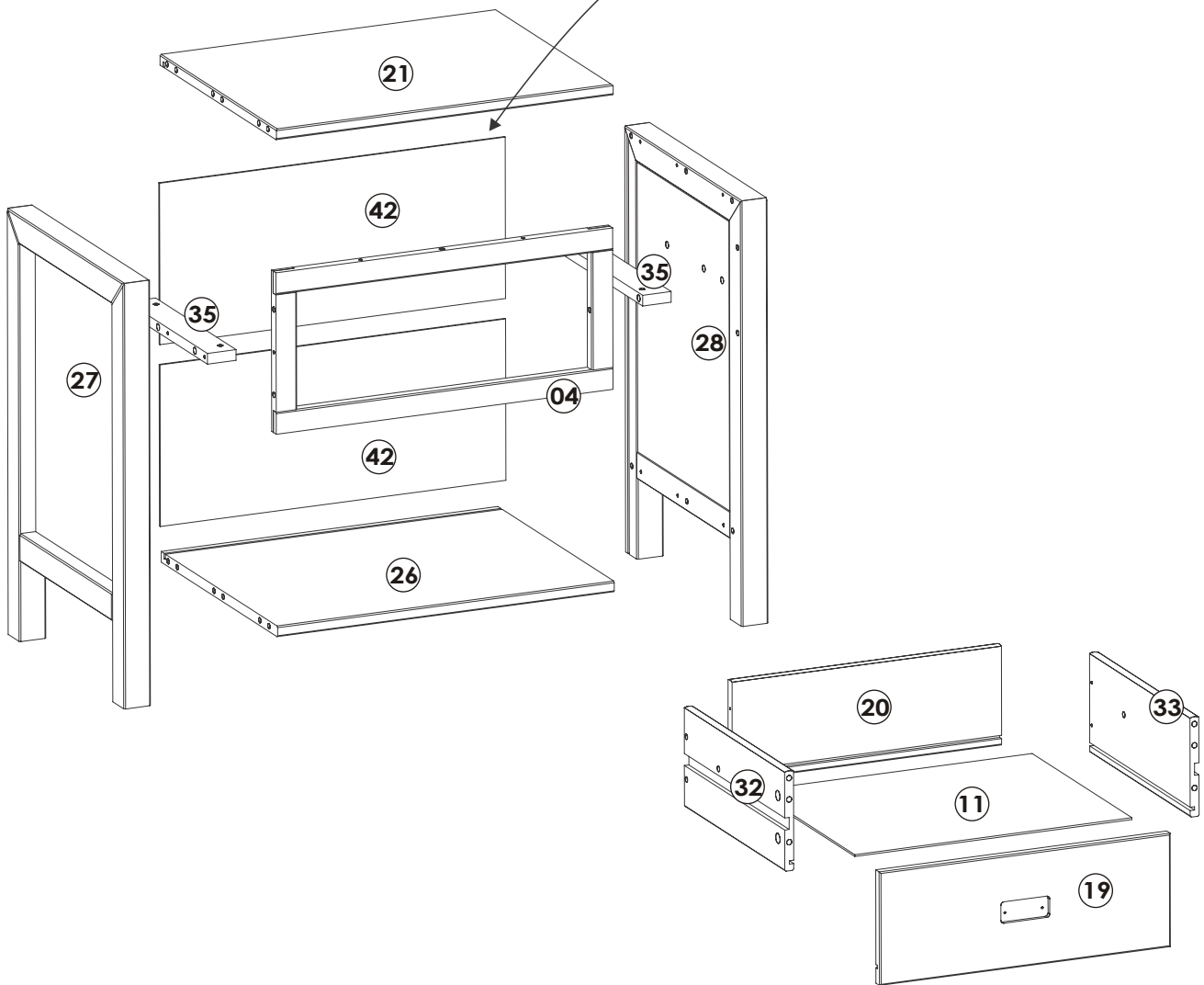

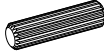

WALKER EDISON
 Distribution By:
 Walker Edison Furniture Company
 1533 W 9000 S, West Jordan,
 UT 84088 United States
 For details on Assembly Videos, Assembly Instructions,
 Replacement Parts and Customer Service, SCAN HERE

LYDIA

Model: XXXXXXXFF
 LOT: AAYYWW-XXX
 Date: MM/20YY
 Rev. MM/20YY-VX
CANER compliant / conforme au CANER
 TSCA Title VI compliant / conforme au titre VI de la TSCA
 TSCA Title VI certified / certifié conformément au titre VI de la TSCA
 California Proposition 65 Compliant / conforme à la Proposition 65

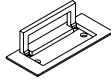

WE Hardware List

Part	Size	Name	Quantity
A	 8x30mm	Wooden dowel	21
B	 10x20mm	Wooden dowel	06
C	 4,0x40mm	Screw	10
D	 3,0x12mm	Screw	02
E	 15x12mm	Cam lock	16
F	 5x24mm	Cam bolt	16
G	 3,5x30mm	Screw	04
H	 8x50mm	Wooden dowel	02
I	 90x40mm	Handle	01
J	 527mm	“H” Profile	01

The hardware quantities listed above are required for proper assembly.
Extra hardware pieces may be included.

Step 1

Let's get started! Insert Wooden Dowel (B) into the Wood Slider (35).

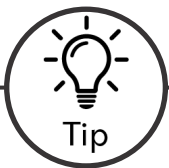
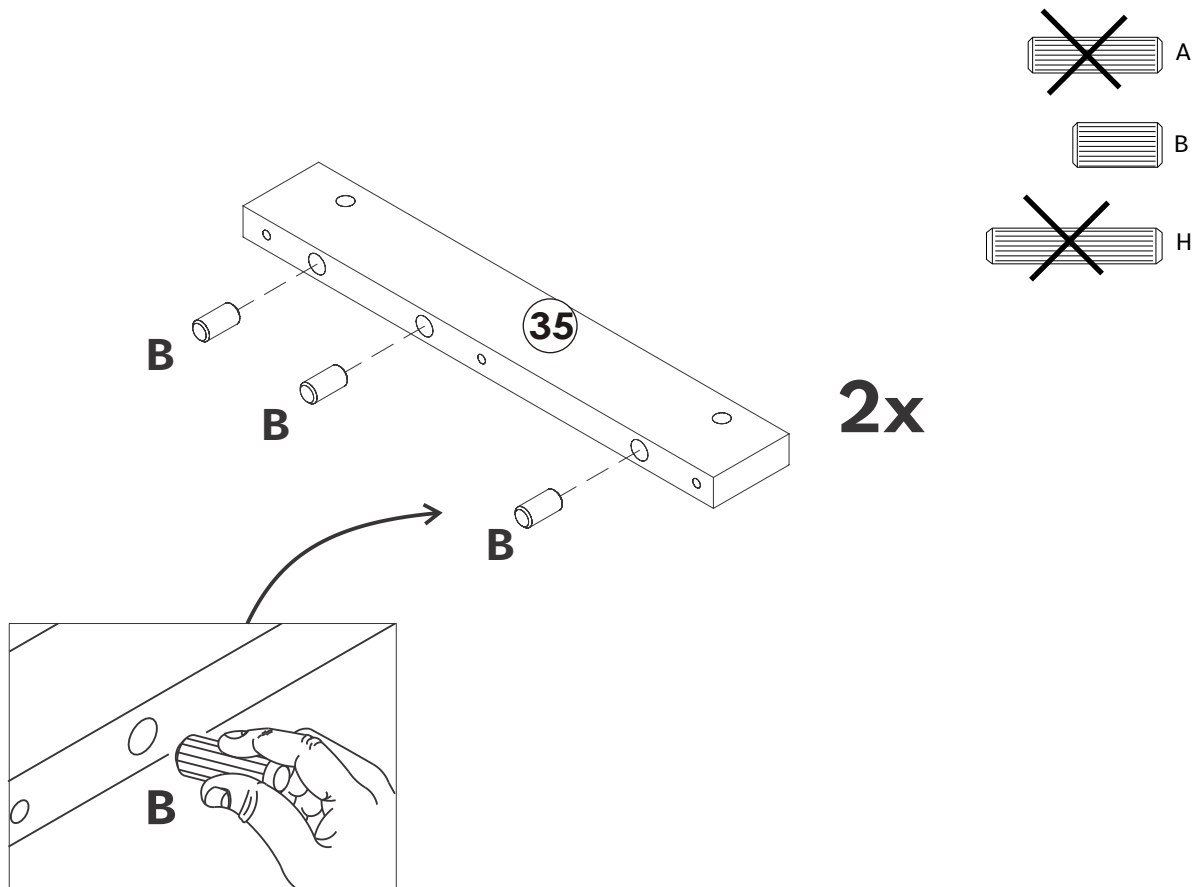
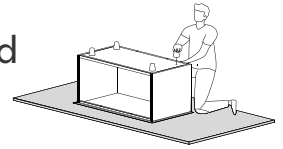

Tip

Wood Dowels

Dowels are essential in furniture assembly to create strong, precise connections.

They ensure structural integrity, prevent shifting, and simplify alignment, resulting in sturdier, longer-lasting furniture.

Follow these steps:

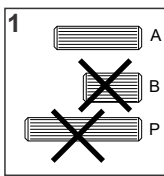

1: Select the appropriate size dowel according with step.

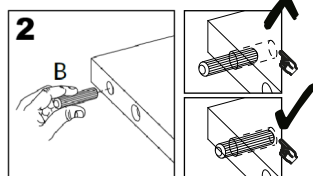

2: Insert into drilled hole and press firmly to ensure placement is set.

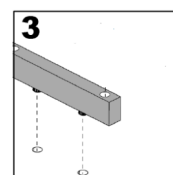

3: Align the dowel with corresponding piece and press together until secure.

Step 2

Insert Wooden Dowel (A) into the Front Frame (04), Top Panel (21), Bottom Panel (26), Left Drawer Side (32) and Right Drawer Side (33).

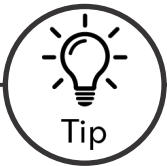
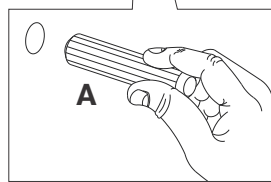
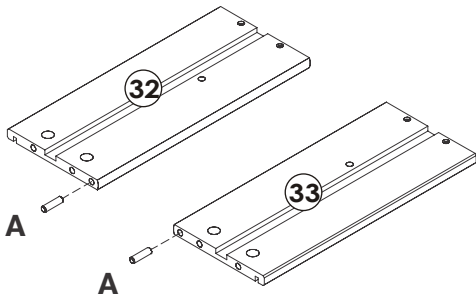
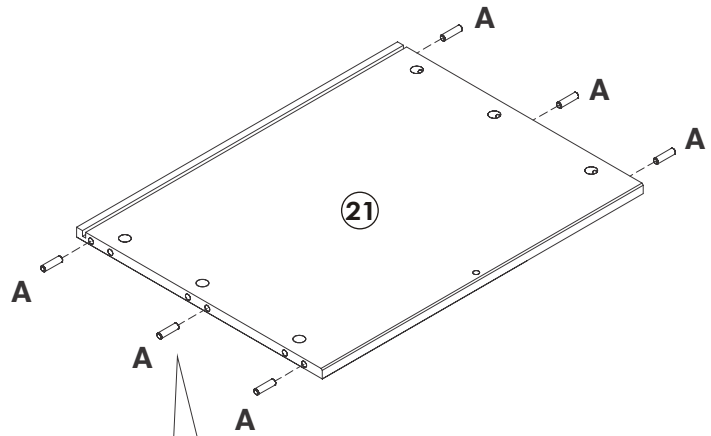
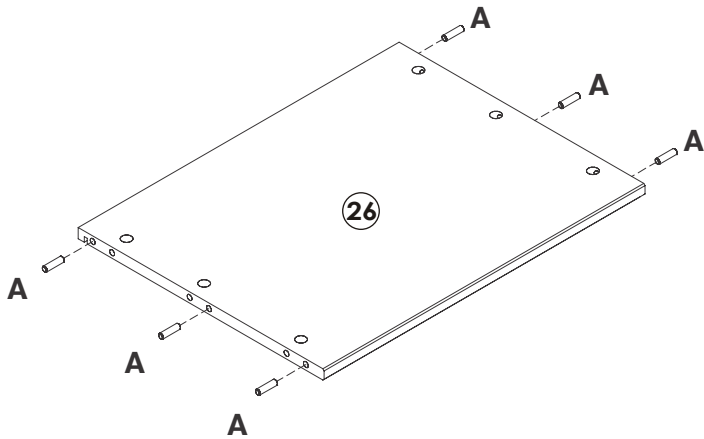
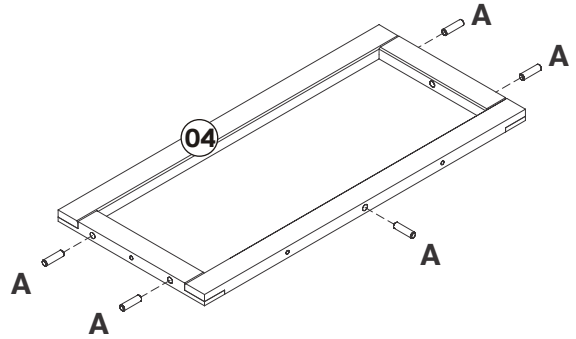
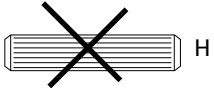
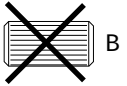

Tip

To keep your product looking its best and scratch-free, try assembling it on a soft surface like carpet or a blanket. This helps prevent any accidental scratches and keeps your furniture in top shape!

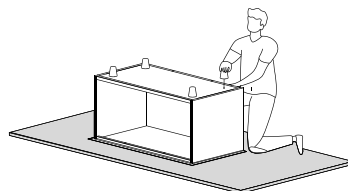

Step 3

Attach Cam Bolt (F) into the holes in Drawer Front (19), Left Side Panel (27) and Right Side Panel (28) with a Phillips head screwdriver.

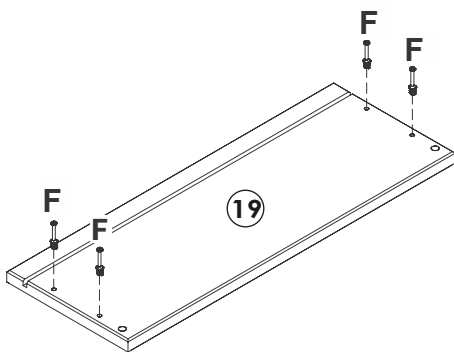
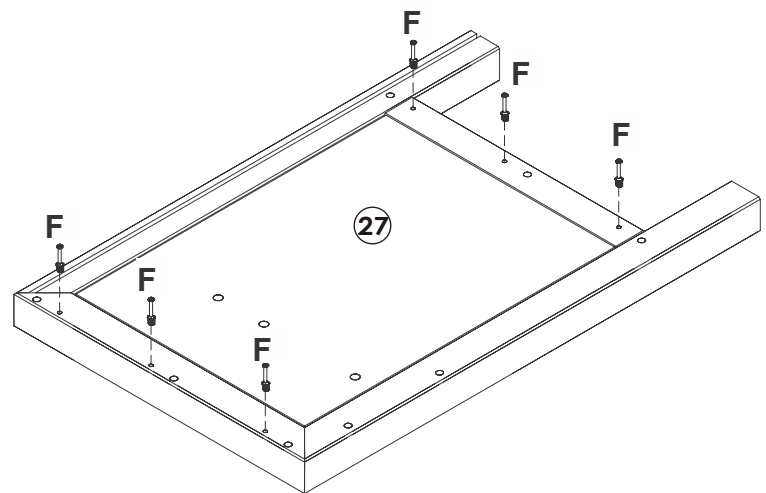
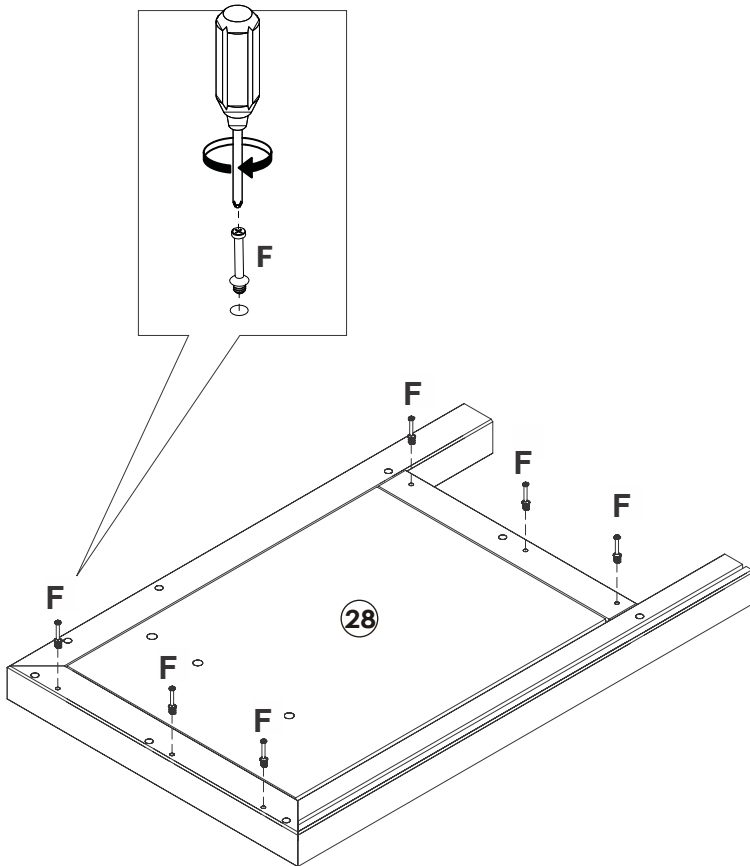
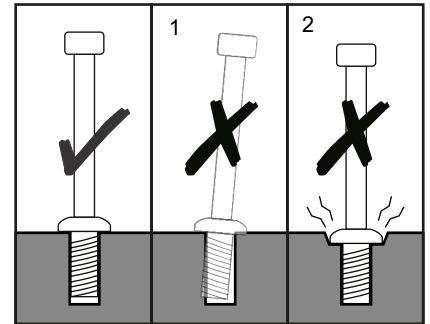
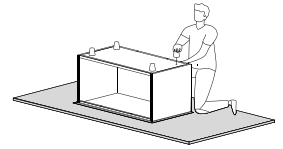

Step 4

Secure the Wood Slider (35) to the Left Side Panel (27) and the Right Side Panel (28) with Screw (C) and a Phillips head screwdriver.

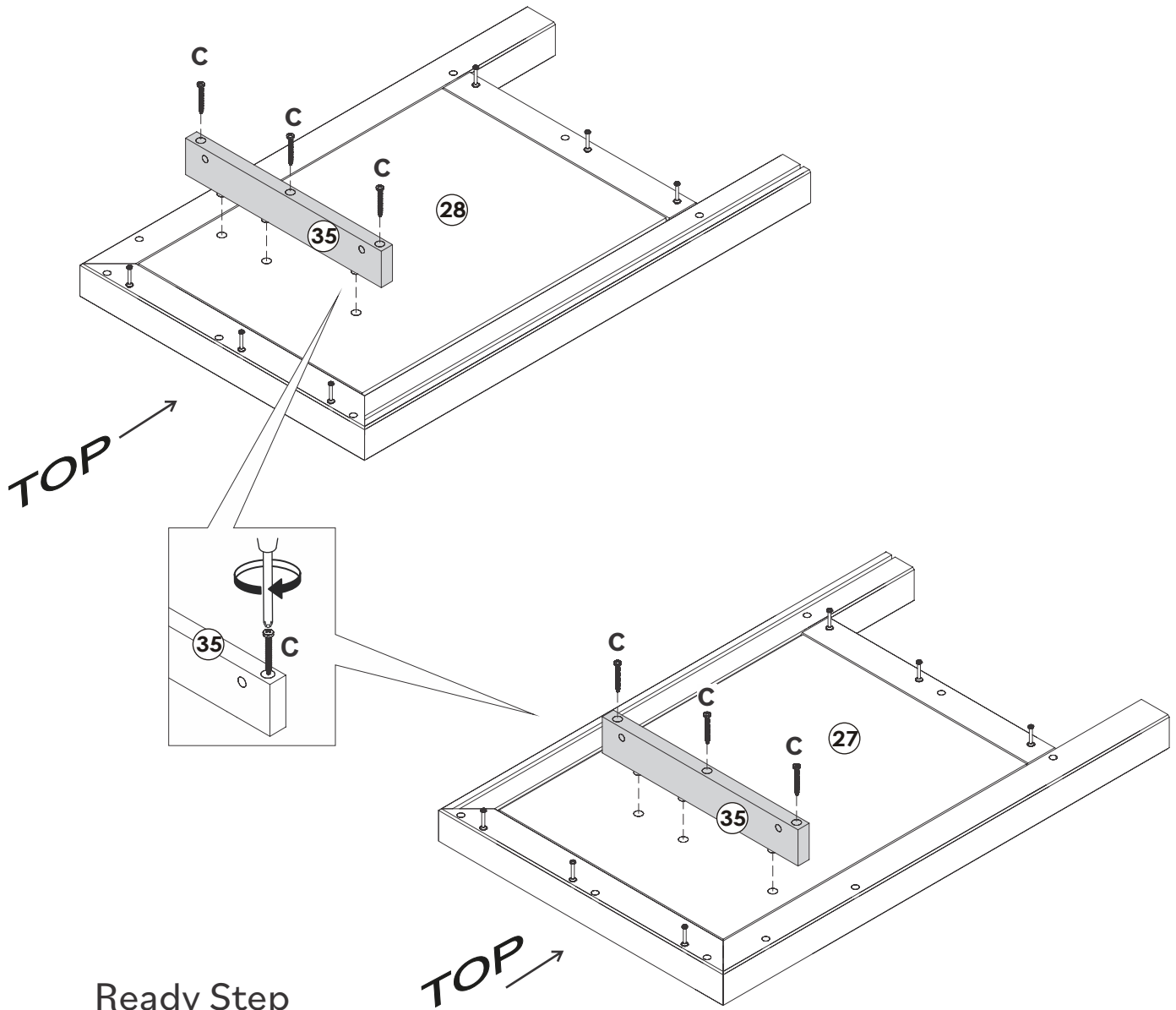
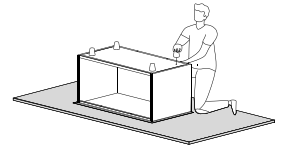

Ready Step

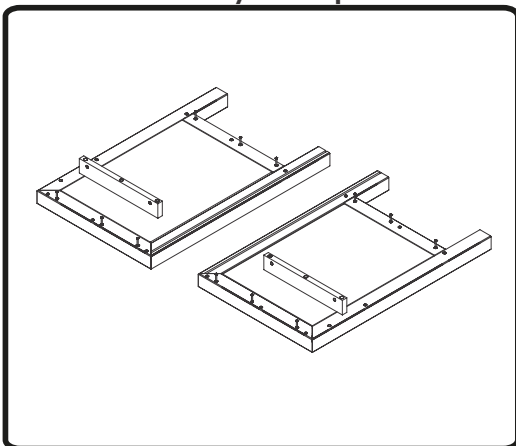

Step 5

Fit the Bottom Panel (26) to Left Side Panel (27). Insert Cam lock (E) in the Bottom Panel (26) and attach with a Phillips head screwdriver.

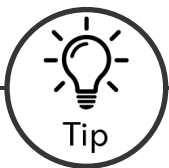
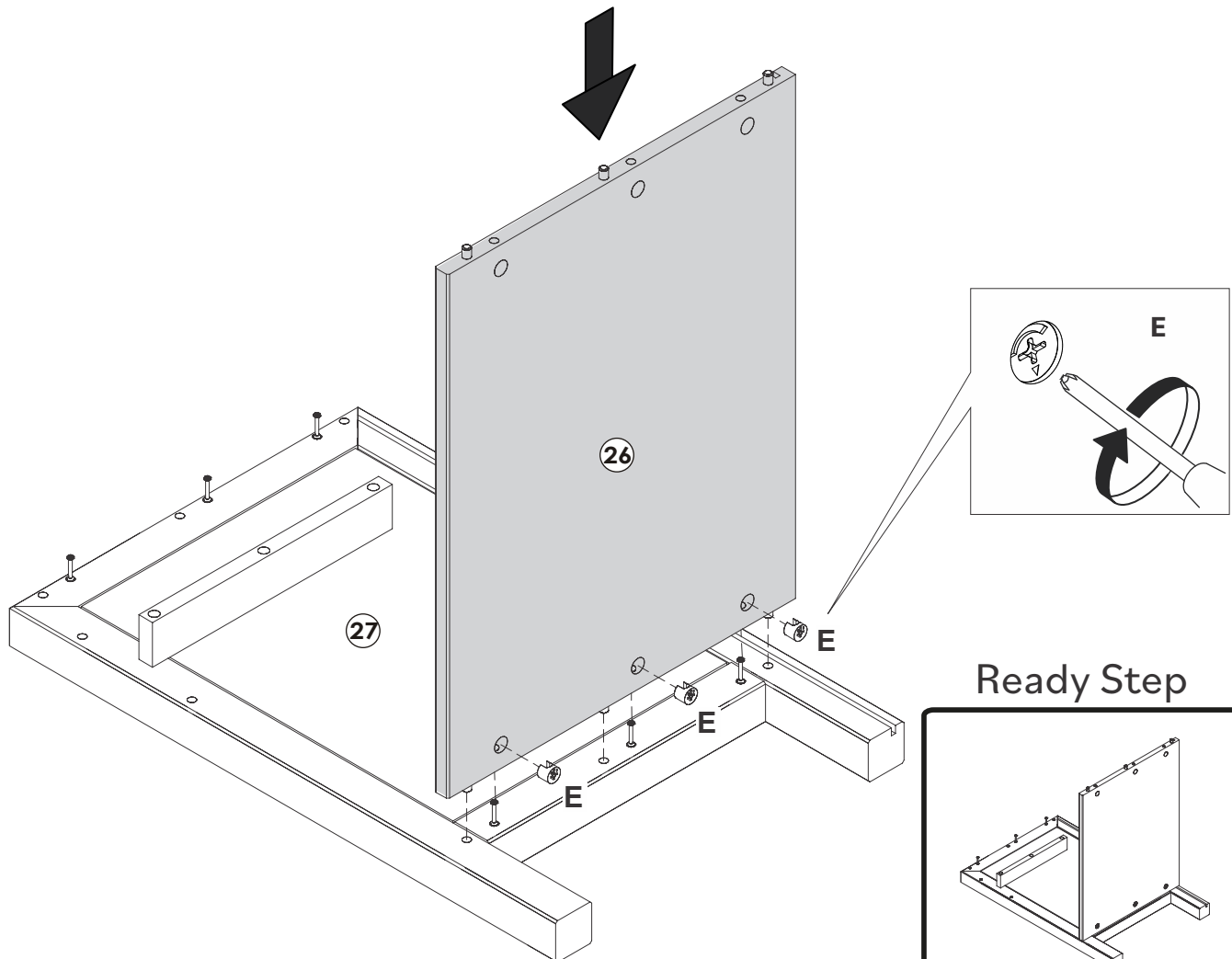
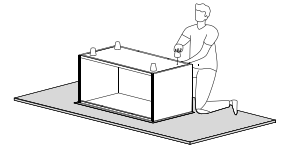

Tip

Cam Locks

Cam Locks help securely join two pieces together.
Follow these easy steps.

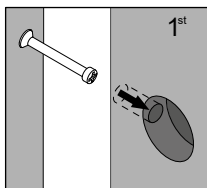

1: Insert Cam Bolt into bolt holes on the flat side. Don't over tighten!

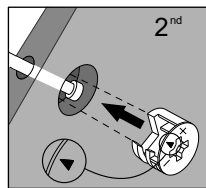

2: Assemble both parts together. The cam bolts go in the drilled holes that have a circular hole on the side, you should be able to see the cam bolt through it. After fitting parts together insert the cam lock on the side holes.

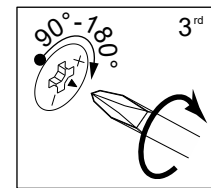

3: On the back of the Cam Lock will be a 'C' shape. Insert the Cam Lock so the opening of the 'C' fits over the Cam Bolt. Tighten with the screwdriver.

Step 6

Fit the Front Frame (04) and Top Panel (21) to Left Side Panel (27). Insert Cam lock (E) in the Top Panel (21) and attach with a Phillips head screwdriver.

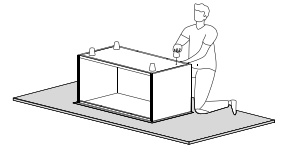

1st

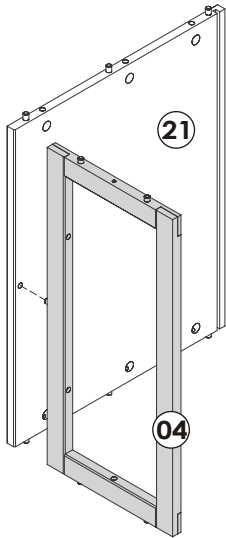

Fit the Front Frame (04) to the Top Panel (21).

2nd

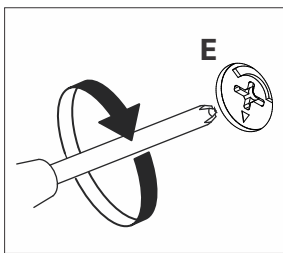
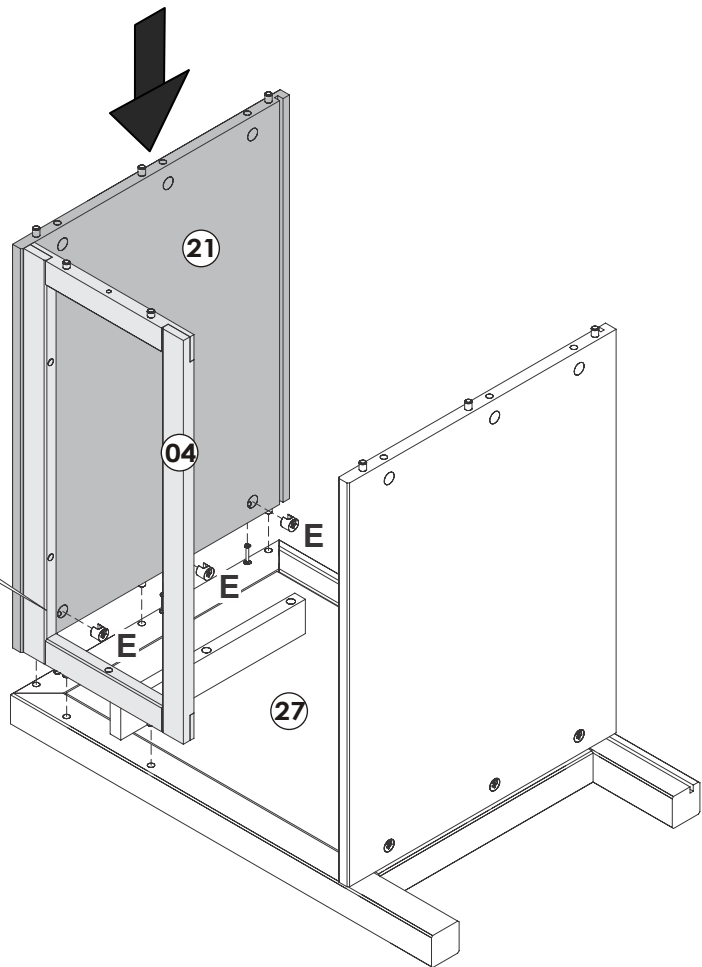

Ready Step

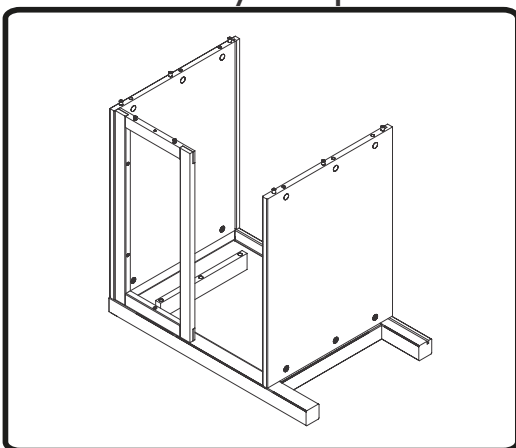

Step 7

Insert "H" Profile (J) into the Back Panel (42). Then, slide Back Panel (42) into the grooves on Top Panel (21) and Bottom Panel (26) fit it in the Left Side Panel (27).

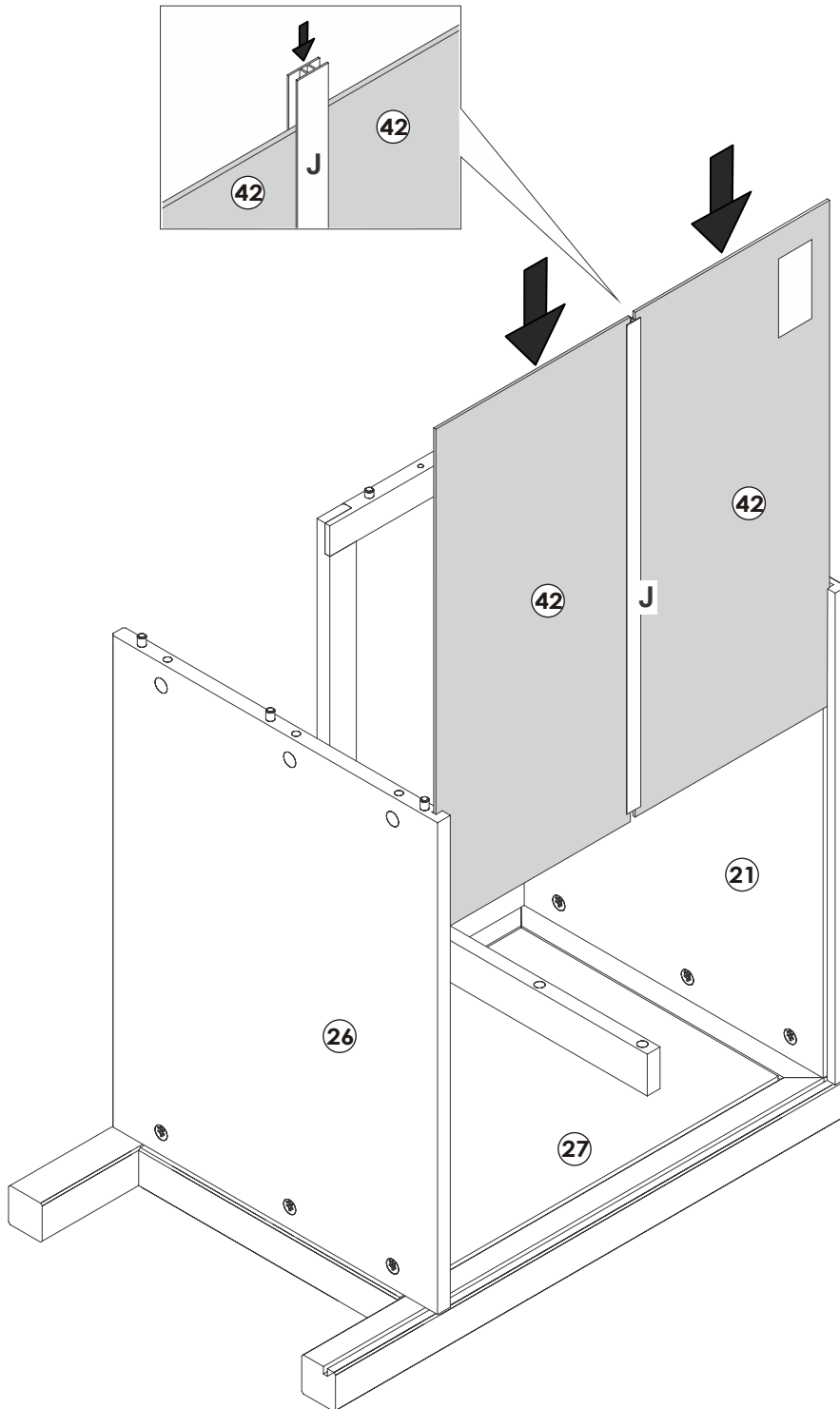
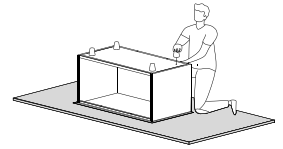

Name and address of the supplier and date of production.

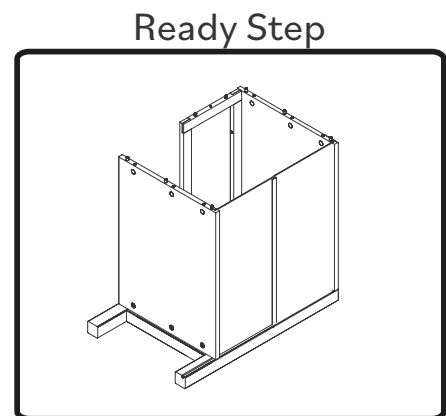

Step 8

Assemble the Right Side Panel (28) to the Front Frame (04), Top Panel (21), Bottom Panel (26) and Back Panel (42).
Insert Cam lock (E) in the Top Panel (21) and Bottom Panel (26), attach with a Phillips head screwdriver.

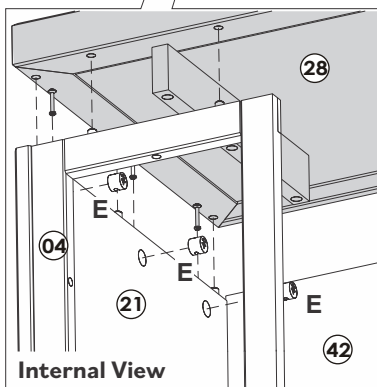
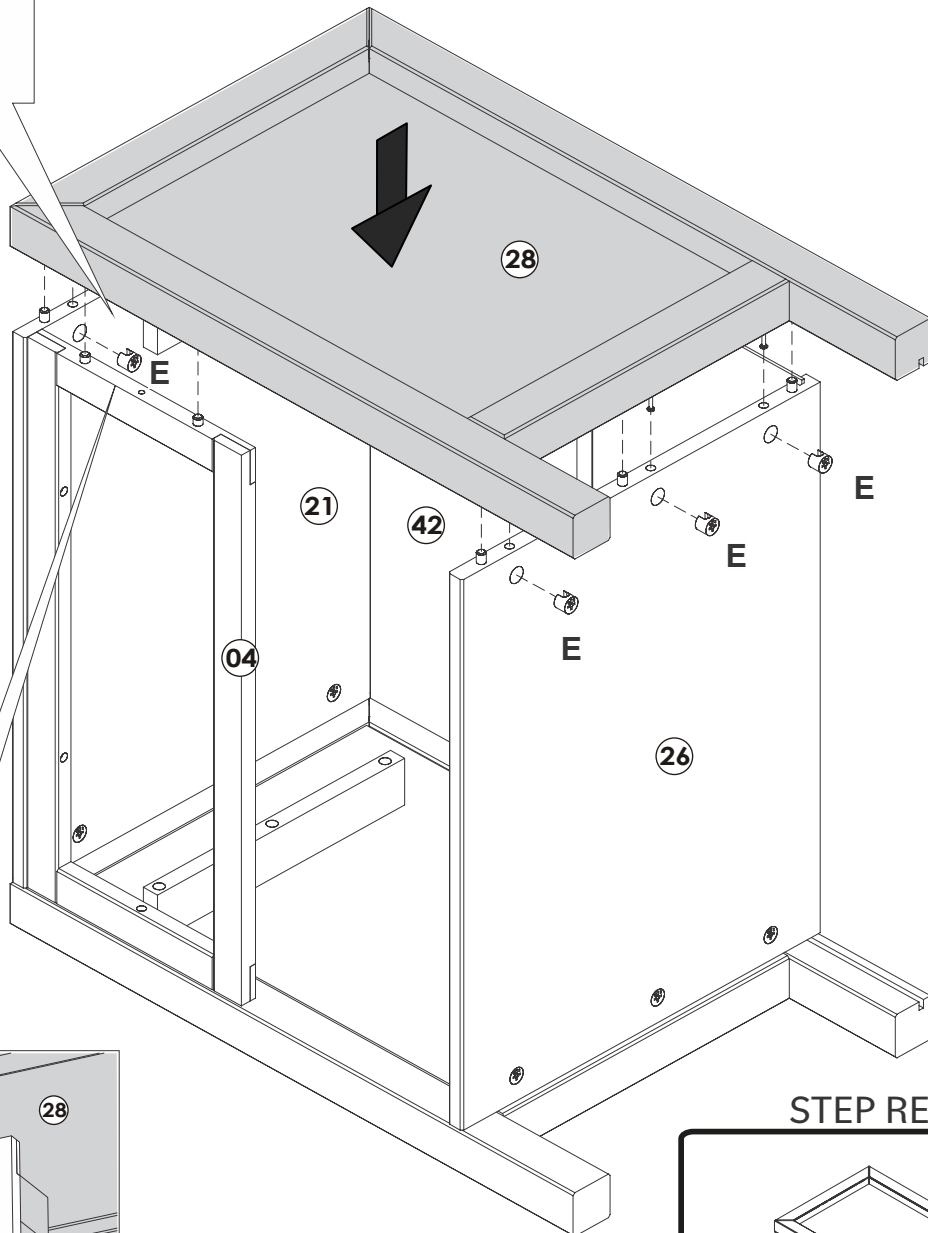
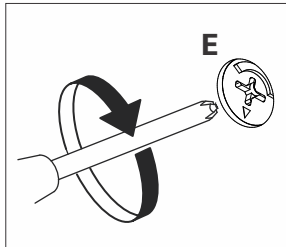
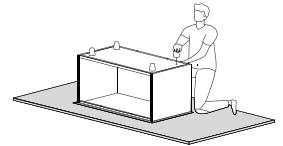

STEP READY

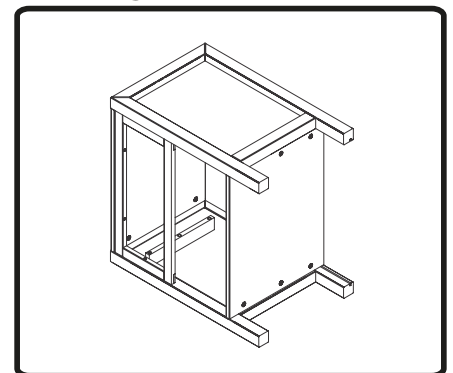

Step 9

Secure the Front Frame (04) to Top Panel (21), Left Side Panel (27) and Right Side Panel (28) using screw (C) and a Phillips head screwdriver.

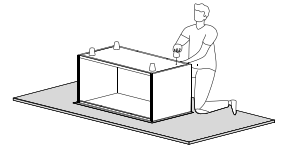

Rotate 90°

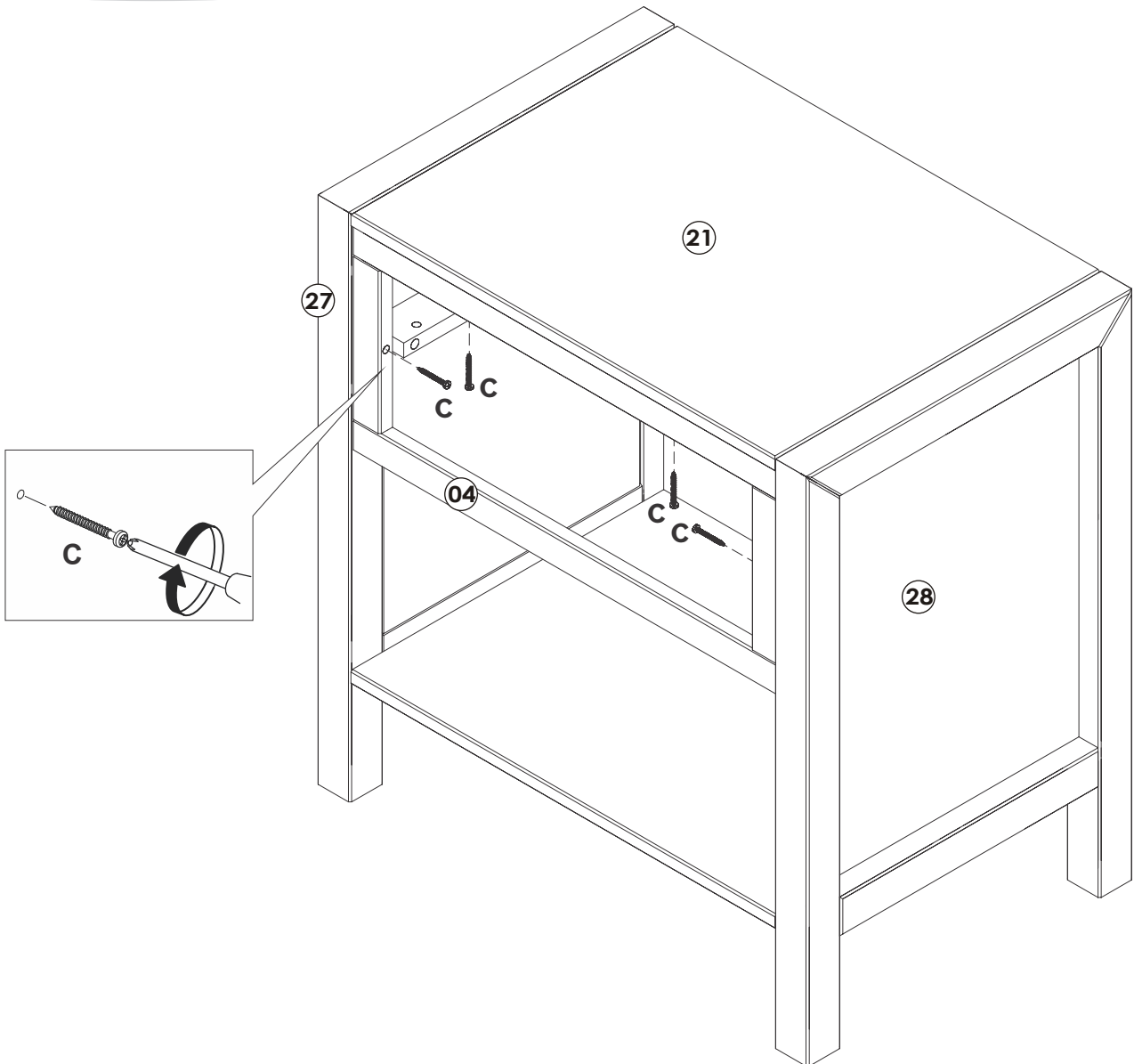
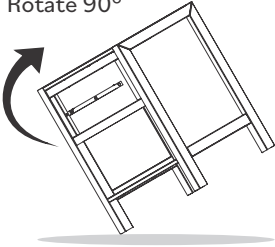

Step 10

Insert Wooden Dowels (A) into the front hole in Wood Slider (35).

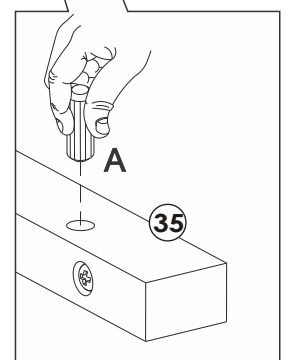
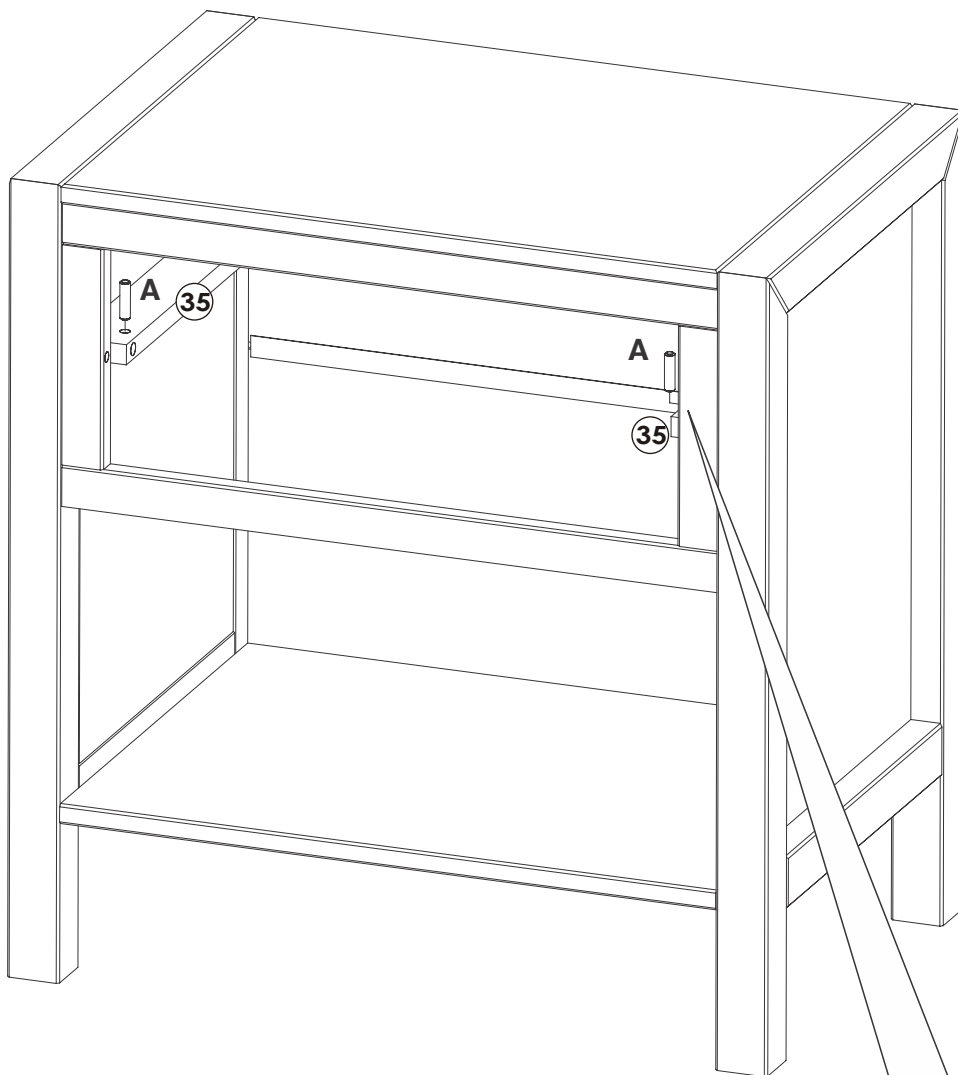
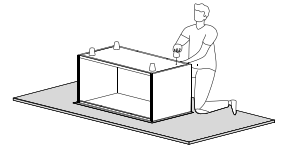

Step 11

Attach Left Side Panel (32) and Right Side Panel (33) to the Drawer Front (19). Insert Cam Lock (E) in the Left Drawer Side (32) and Right Drawer Side (33), tighten with Phillips head screwdriver.

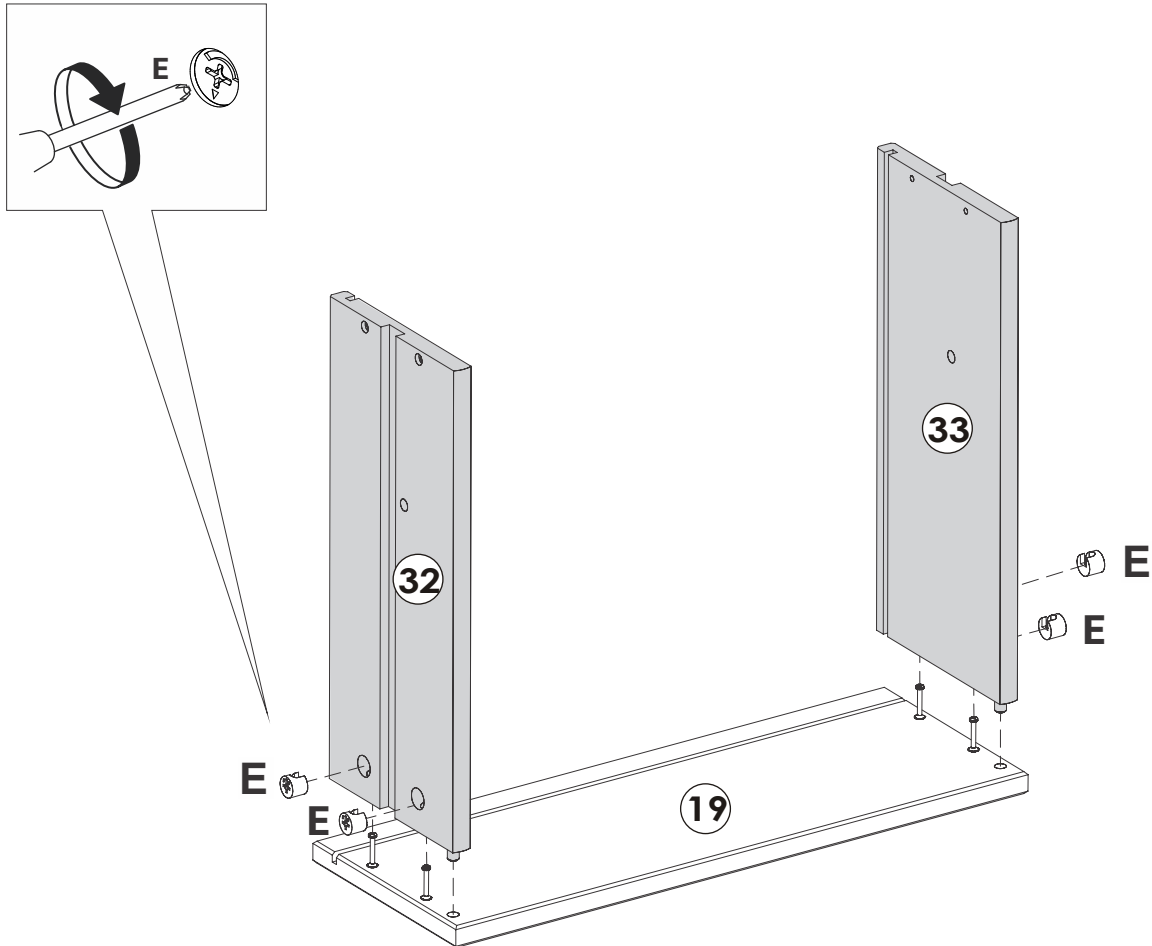
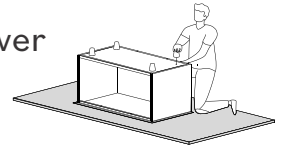

STEP READY

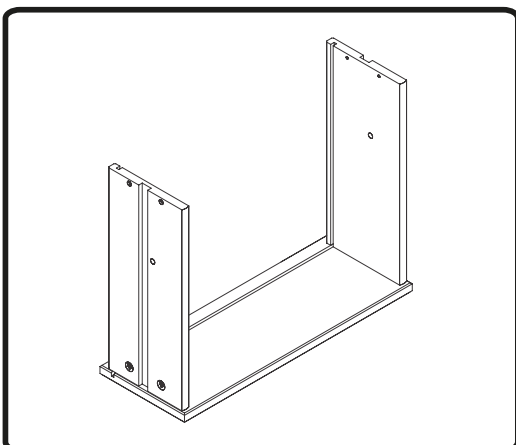

Step 12

Slide Drawer Bottom (11) in the grooves on Left Drawer Side (32) and Right Drawer Side (33), also secure Drawer Back (20) with Screw (G) and a Phillips head screwdriver.

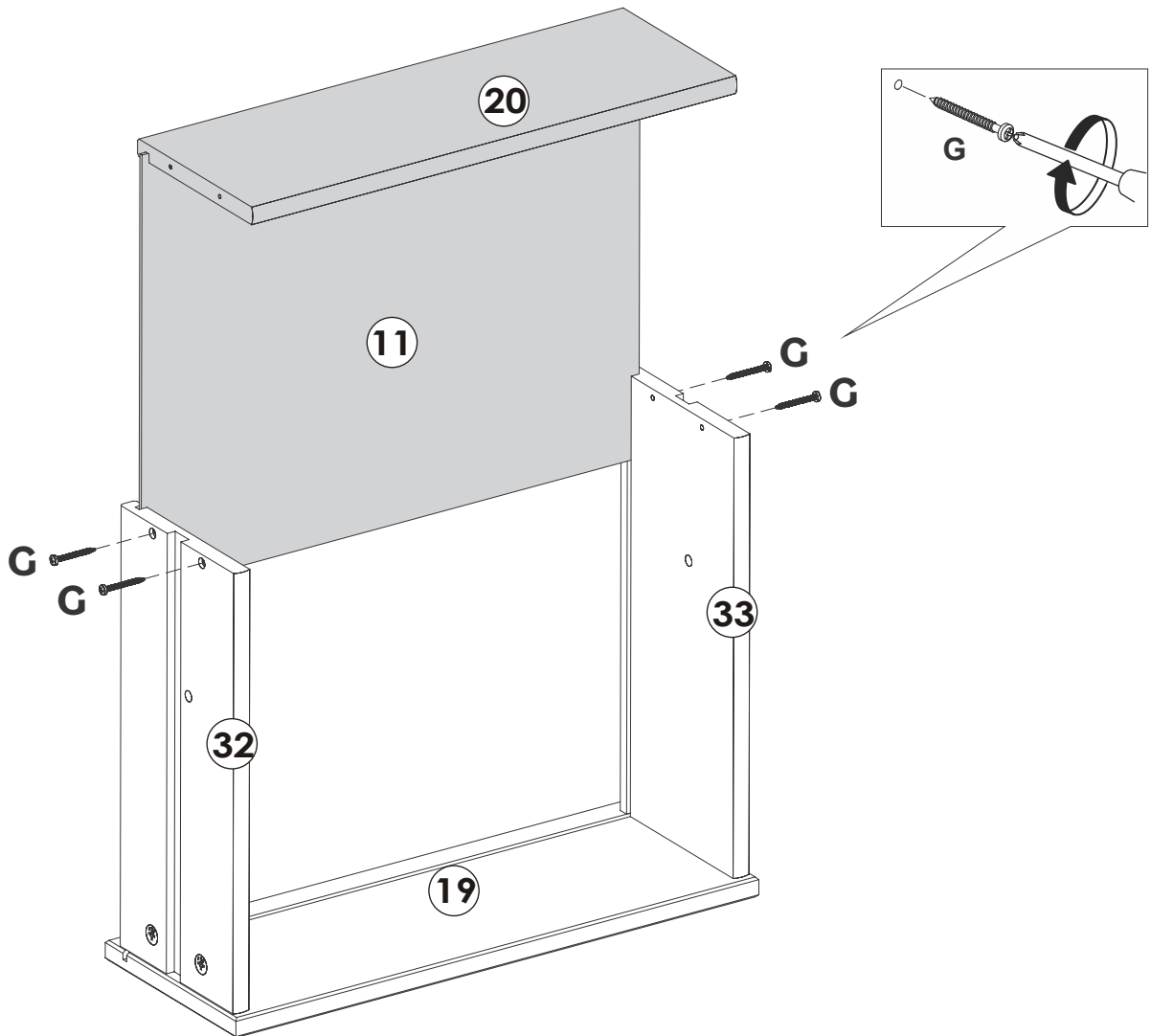
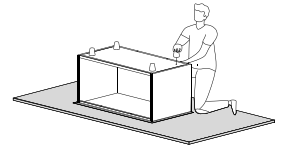

STEP READY

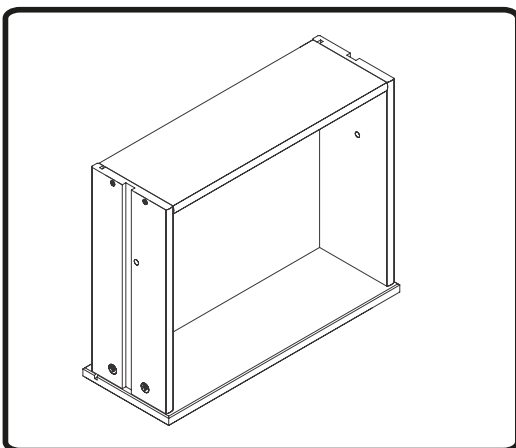

Step 13

Attach Handle (I) using Screw (D) and a Phillips head screwdriver.

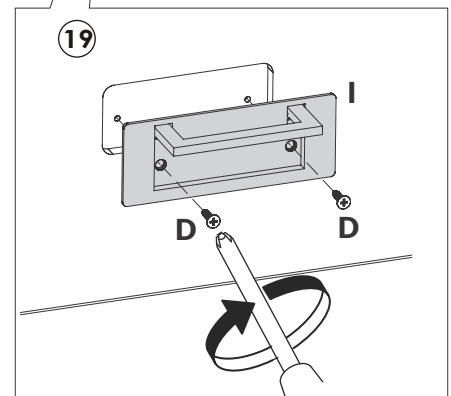
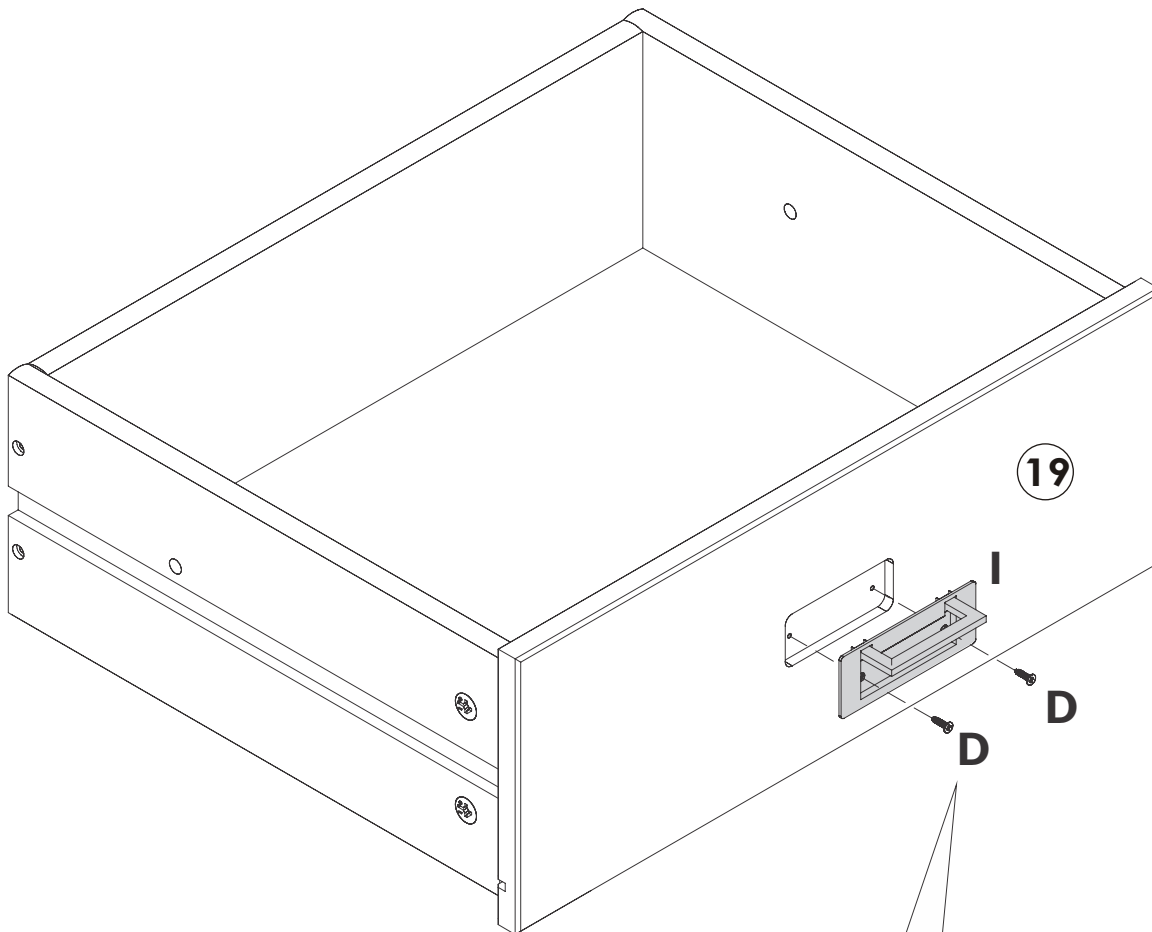
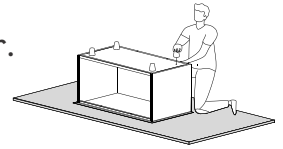

Step 14

Insert wooden dowel (H) on the inside of all drawers, with the drawer inside the unit after having passed the wooden dowel that is in the drawer slide. The dowel is not flush with the panel, it is a little inside the drawer to help when you need to remove the lock dowel to remove the drawer.

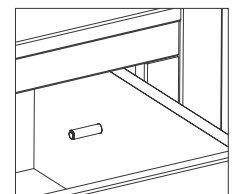
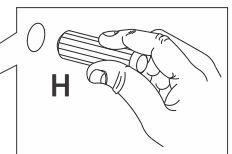
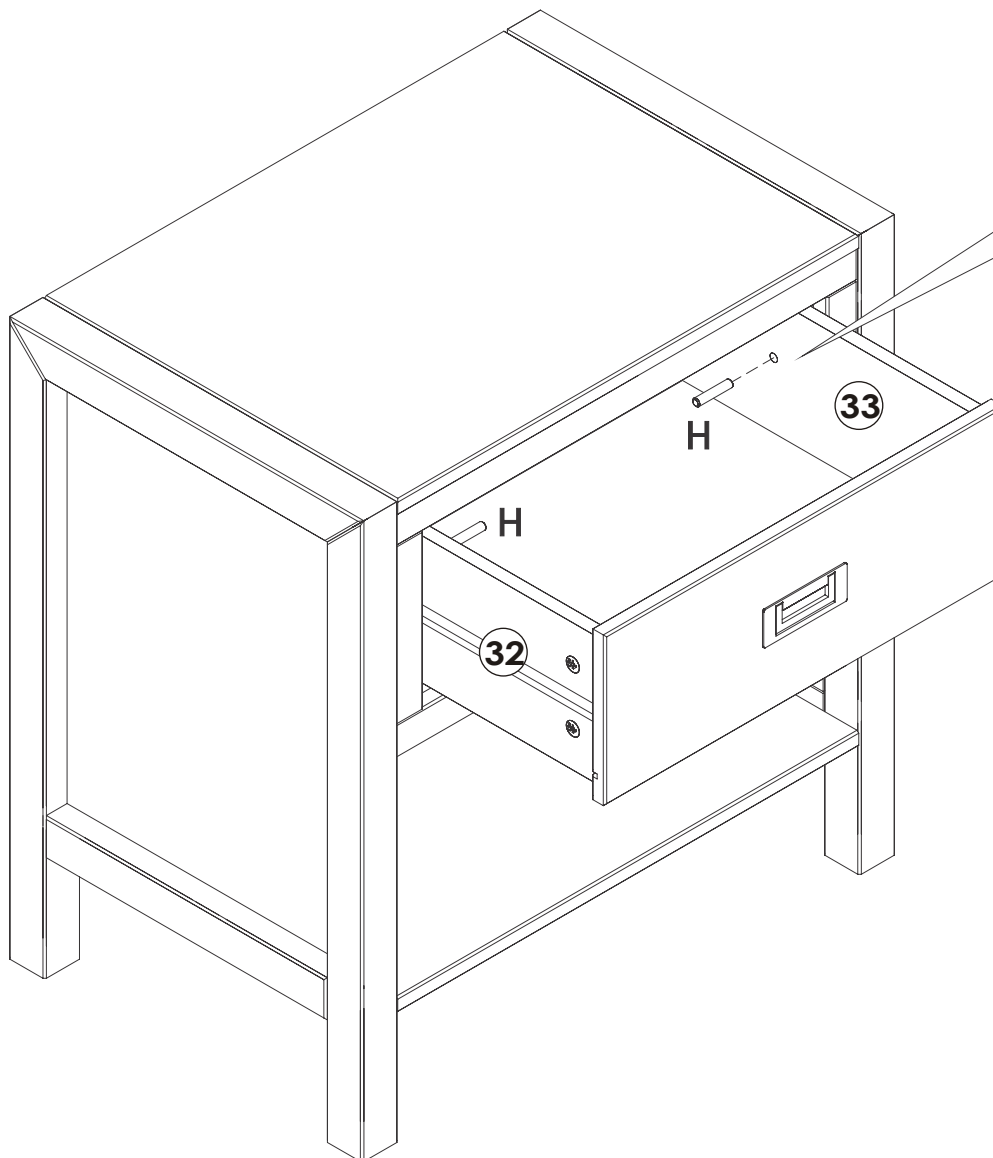
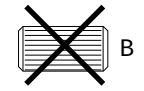
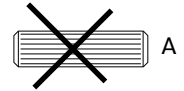
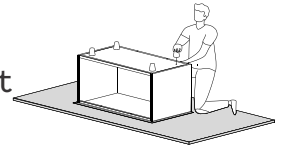

You did it! Enjoy your new nightstand!

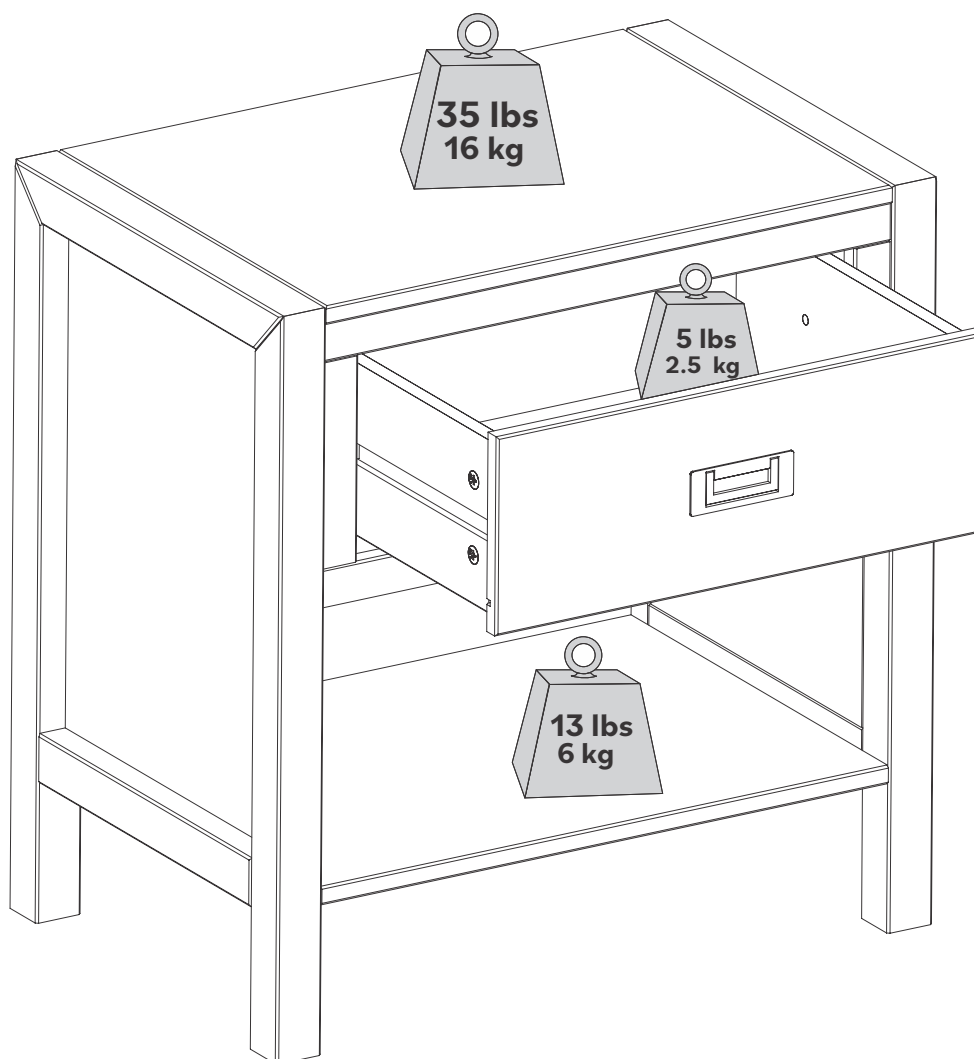

Congratulations on your new piece of furniture!
We would love to hear about it and see it.
Please leave us a review or post a picture with
[#mywalkerredisonhome](#)

Assembling furniture can be tricky sometimes.

Our customer service team, located in Utah, is here for product information, help assembling a product, or for any other customer support issue

Call us at **801-433-3008**

Email us at **service@walkeredison.com**

Visit our Customer Service website at

walkeredison.com/pages/customer-service

We are available to help Monday-Thursday 8am-5pm, Friday 8am-3pm MST

For details on Assembly Videos, Assembly Instructions, Replacement Parts, and Customer service,

SCAN HERE

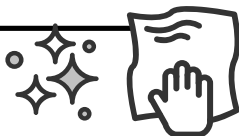

For cleaning, never use abrasives, use a soft cloth and water with neutral soap to clean the furniture.

WALKER EDISON™

Tablet de Chevet Lydia avec 1 Tiroir Mesita de Noche Lydia con 1 Cajón

SKU: BR1DLYDNS
LOT: **AAYYWW-XXX**

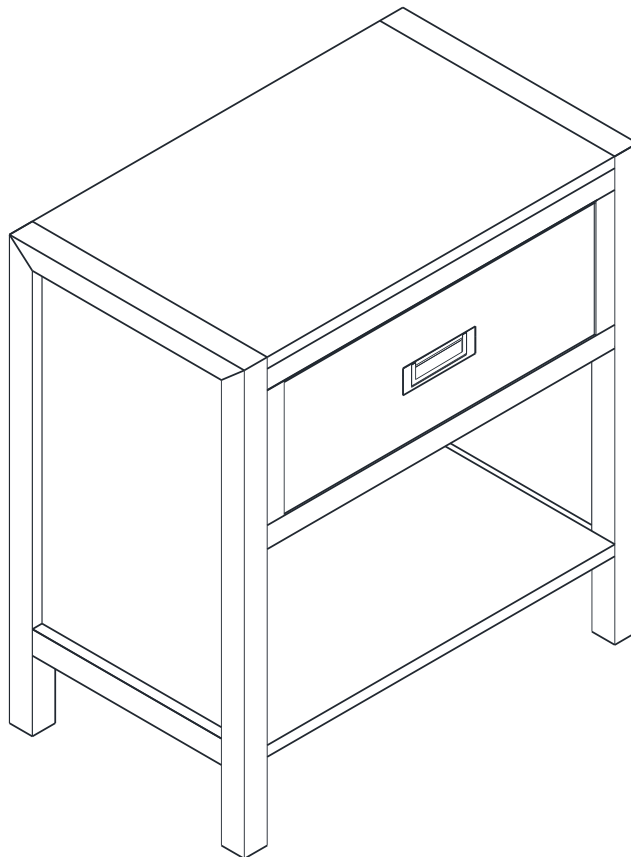

Pour usage résidentiel seulement

Visite notre site Web pour obtenir les instructions les plus récentes, des conseils d'assemblage, signaler des dommages ou commander des pièces. www.walkeredison.com

Sólo para uso residencial

Visite nuestro sitio web para consultar las últimas instrucciones, consejos de montaje, notificar daños o solicitar piezas. www.walkeredison.com

WE Il est temps de commencer / Hora de empezar

Prépare un lieu de travail propre et souple pour éviter tout dommage lors de l'assemblage. Tu peux utiliser la boîte et les protections internes comme base. Vérifie également que tu disposes de toutes les pièces et parties avant de te lancer dans l'assemblage.

Prepare un lugar de trabajo limpio y blando para evitar daños durante el montaje. Puede utilizar la caja y las protecciones internas como base. Comprueba también que tiene todas las piezas y partes antes de sumergirse en el montaje.

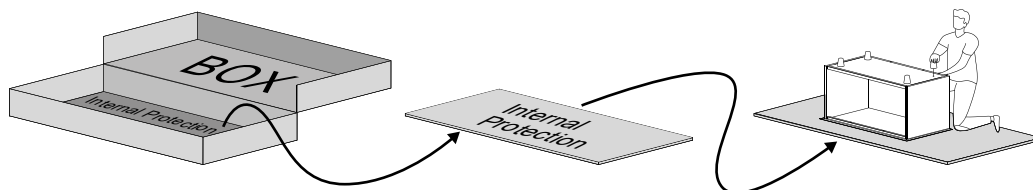

**Temps de montage
estimé**

**Tiempo estimado
de montaje**

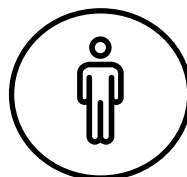
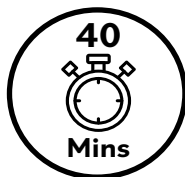

1 Person Build

Vous pouvez le faire seul.

Mais vous pouvez en faire un travail d'équipe !
Demandez à un ami de vous aider à l'assembler plus rapidement et plus facilement.

Puedes hacerlo solo

Pero también puedes hacerlo en equipo.
Llévate a un amigo para que el montaje sea más rápido y sencillo.

Outils nécessaires

Munis-toi d'un tournevis cruciforme pour réaliser cet assemblage

Herramientas requeridas

Tome un destornillador Phillips para conquistar este conjunto.

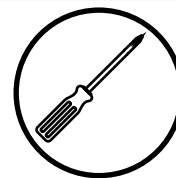

Utilise les outils électriques avec précaution

Ce meuble est réalisé en Bois Massif et Bois Composite, des matériaux souples. Si tu choisis d'utiliser des outils électriques, règle-les sur le mode le plus lent. Fais attention à toi ! Les outils électriques peuvent provoquer des fissures ou endommager les meubles, mais aussi les autres composants s'ils sont mal utilisés. Les dommages causés par un outil électrique ne sont pas couverts par la garantie Walker Edison.

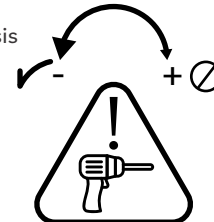

Utilice las herramientas eléctricas con cuidado

Este mueble está fabricado con madera maciza y madera compuesta, materiales blandos. Si decide utilizar herramientas eléctricas, ajústelas al ajuste más lento. Tenga cuidado. Las herramientas eléctricas pueden causar grietas o daños en el mueble, pero también en los herrajes si se utilizan mal. Los daños causados por una herramienta eléctrica no están cubiertos por la garantía de Walker Edison.

Attention avec la glissière

Tes meubles possèdent des glissières en bois très résistantes. De temps en temps, nous recommandons d'appliquer de la paraffine ou de la cire de bougie standard pour améliorer la glisse des curseurs.

Cuidado con las guías

Tus muebles cuentan con guías de madera de alta durabilidad. De vez en cuando, recomendamos la aplicación de parafina o cera estándar para mejorar el deslizamiento de los deslizadores.

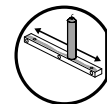

Scannez pour obtenir des conseils d'assemblage et de l'aide !
Escanee para obtener consejos de montaje y ayuda!

WE Liste de pièces / Lista de piezas

Nombre de pièces Número de pieza	Description Descripción	Quantité Cantidad
04	Panneau du Façade Panel Delantero	01
11	Fond du Tiroir Fondo del Cajón	01
19	Façade du Tiroir Frente del Cajón	01
20	Arrière du Tiroir Trasera del Cajón	01
21	Panneau Supérieur Panel Superior	01
26	Panneau Inférieur Panel Inferior	01

Nombre de pièces Número de pieza	Description Descripción	Quantité Cantidad
27	Panneau Gauche Panel Izquierdo	01
28	Panel Droit Panneau Izquierdo	01
32	Côté Gauche du Tiroir Lado Izquierdo del Cajón	01
33	Côté Droit du Tiroir Lado Derecho del Cajón	01
35	Glissières en Bois Correderas de Madera	02
42	Panneau Arrère Panneau Trasero	02







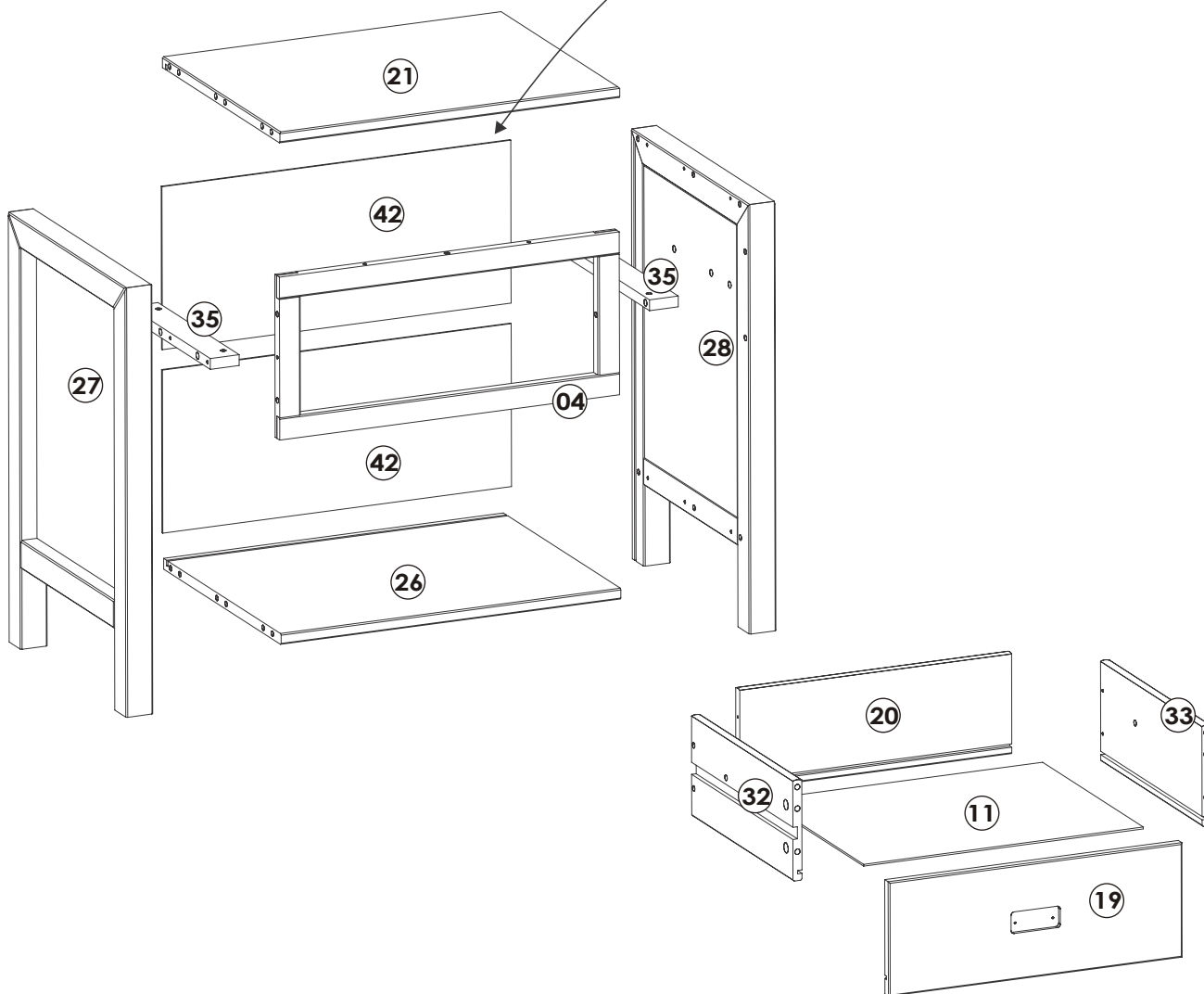

WALKER EDISON
 Distribution By:
 Walker Edison Furniture Company
 1533 W 9000 S, West Jordan,
 UT 84088 United States
 For details on Assembly Videos, Assembly Instructions,
 Replacement Parts and Customer Service, SCAN HERE

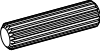
LYDIA

Model: XXXXXXXFF
 LOT: AAYYWW-XXX
 Date: MM/20YY
 Rev. MM/20YY-VX
CANER compliant / conforme au CANER
 TSCA Title VI compliant / conforme au titre VI de la TSCA
 TSCA Title VI certified / certifié conformément au titre VI de la TSCA
 California 93025 Compliant for Formaldehyde /
 California 93025 Compliant for Formaldehyde

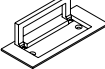
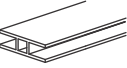

WE Liste de composants / Lista de hardware

Partie Parte	Taille Tamaño	Nom Nombre	Quantité Cantidad
A 	8x30mm	Cheville en bois Espiga de madeira	21
B 	10x20mm	Cheville en bois Espiga de madeira	06
C 	4,0x40mm	Vis Tornillo	10
D 	3,0x12mm	Vis Tornillo	02
E 	15x12mm	Boitier de Assemblage Traba del Conector	16
F 	5x24mm	Goujon de Assemblage Conector	16
G 	3,5x30mm	Vis Tornillo	04
H 	8x50mm	Cheville en bois Espiga de madeira	02
I 	90x40mm	Poignéé Manija	01
J 	527mm	Profil "H" Perfil "H"	01

Les quantités de composants indiquées ci-dessus sont nécessaires pour un assemblage correctt.
Des pièces supplémentaires peuvent être incluses.

Las cantidades de tornillería indicadas anteriormente son necesarias para un montaje correcto.
Se pueden incluir piezas de ferretería adicionales.

Étape / Paso 1

(FR)

Commençons! Insérez les Chevilles (B) dans les Glissières (35).

(ES)

¡Manos a la obra! Inserta las Espigas (B) en las Correderas (35).

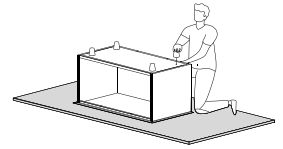

Attention to the
dowel length:
ø10*20mm

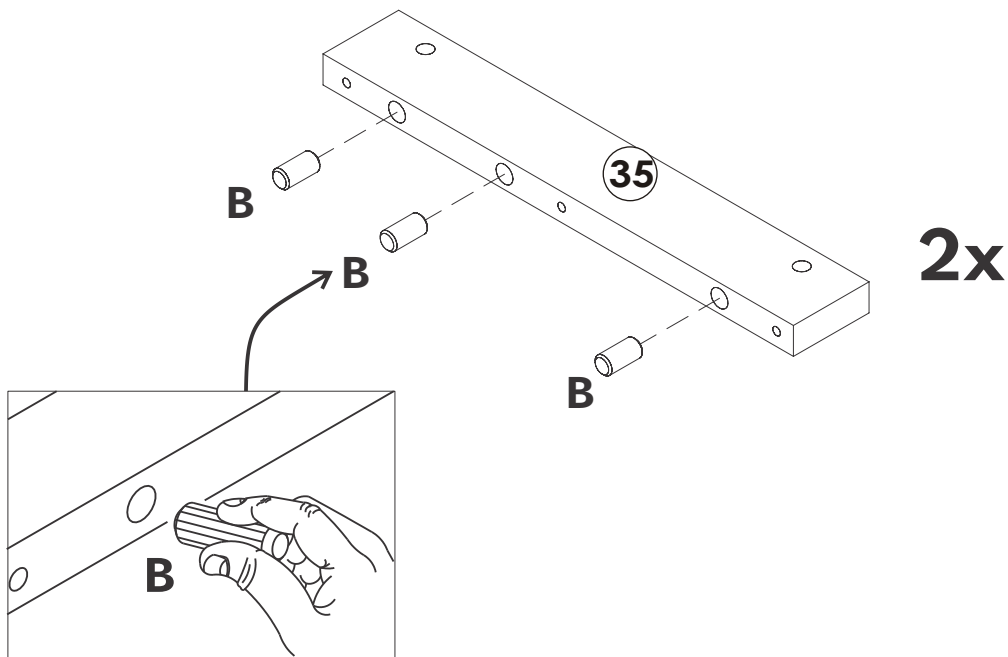
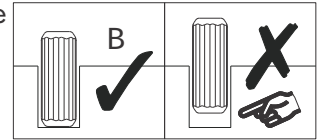

Les chevilles sont essentielles lors de l'assemblage de meubles pour créer des connexions solides et précises. Elles garantissent l'intégrité structurelle, empêchent les déplacements et simplifient l'alignement, ce qui permet d'obtenir des meubles plus résistants et plus durables. Suis ces étapes:

Las espigas son esenciales en el montaje de muebles para crear uniones fuertes y precisas. Garantizan la integridad estructural, evitan el desplazamiento y simplifican la alineación, lo que se traduce en muebles más resistentes y duraderos. Sigue estos pasos:

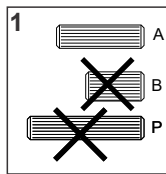

1: Sélectionne la taille de cheville appropriée en fonction de l'étape.
1: Seleccione el tamaño de espiga adecuado según el paso.

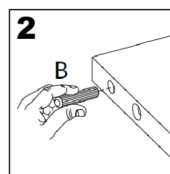

2: Insère dans le trou indiqué et appuie fermement pour assurer un positionnement correct.
2: Insértela en el orificio indicado y presione firmemente para asegurar su correcta colocación.

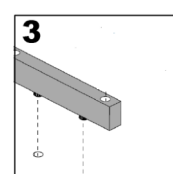
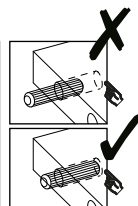

3: Aline la cheville avec la pièce correspondante et enfonce-la jusqu'à ce qu'elle soit ferme.
3: Alinee el pasador con la pieza correspondiente y presiónelo hasta que encaje

Étape / Paso 2

(FR)

Insérez les Chevilles (A) dans le Panneau du Façade (4), Panneau Supérieur (21), Panneau Inférieur (26), Côté Gauche du Tiroir (32) et Côté Droit du Tiroir (33).

(ES)

Inserta las Espigas (A) en el Panel Delantero (4), Panel Superior (21), Panel Inferior (26), Lado Izquierdo del Cajón (32) y Lado Derecho del Cajón (33).

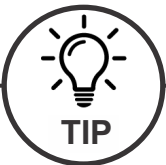
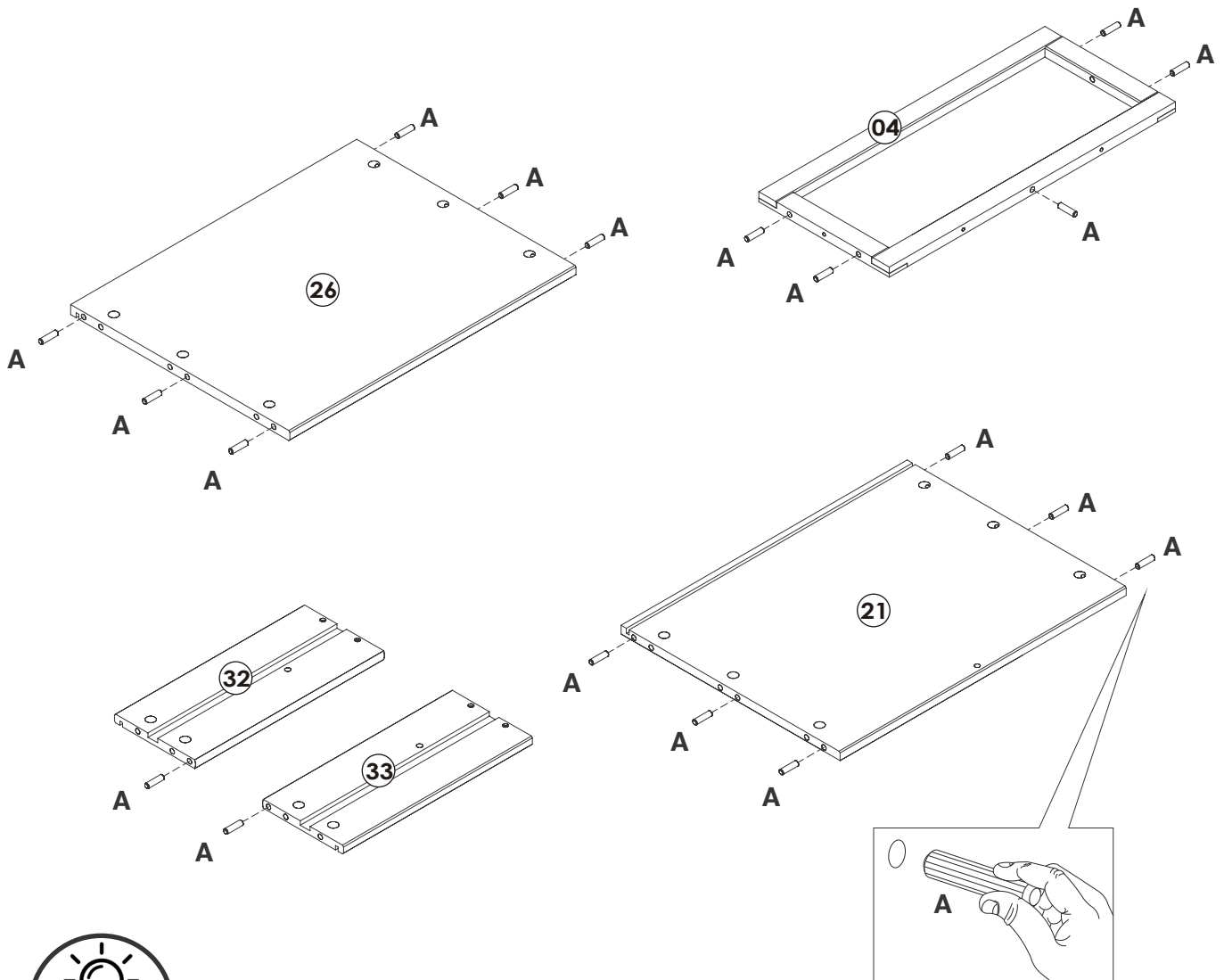

Pour que ton produit conserve son meilleur aspect et sans rayures, essaie de le monter sur une surface souple telle qu'un tapis ou une couverture. Cela permet d'éviter les rayures accidentelles et de garder tes meubles en bon état!

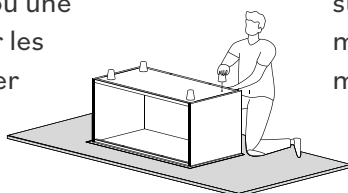

Para mantener su producto con el mejor aspecto y sin arañazos, pruebe a montarlo sobre una superficie blanda, como una alfombra o una manta. Así evitará arañazos accidentales y mantendrá sus muebles en perfecto estado.

Étape / Paso 3

(FR)

Fixes le Goujon de Assemblage (F) dans le Façade du Tiroir (19), Côté Gauche du Tiroir (27) et Côté Droit du Tiroir (28) l'avec de un Clé Phillips

(ES)

Fije los Conectores (F) en la Frente del Cajón (19), Lado Izquierdo del Cajón (27) y Lado Derecho del Cajón (28) con una llave Phillips.

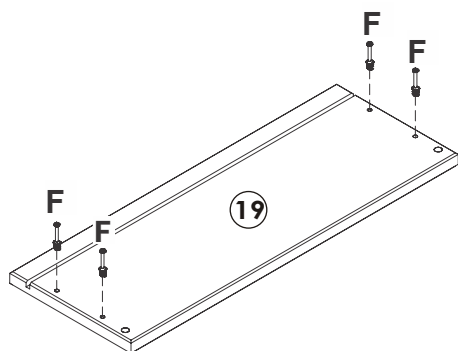
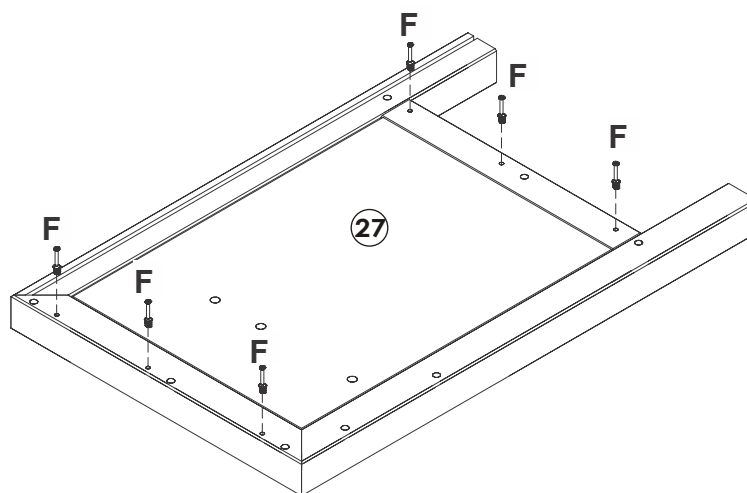
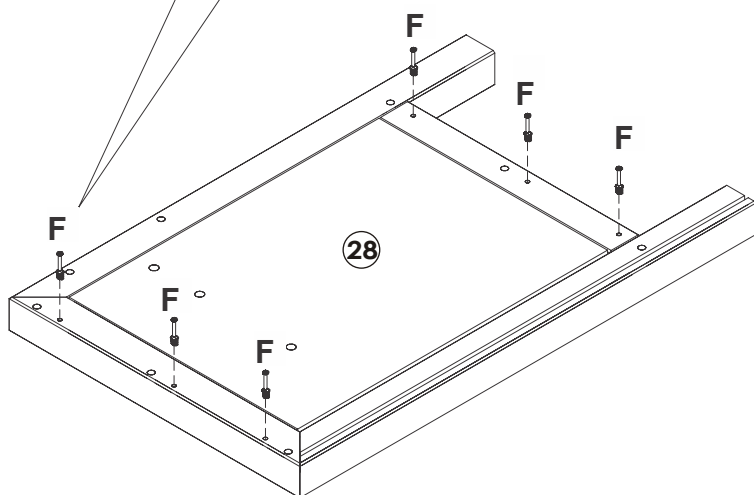
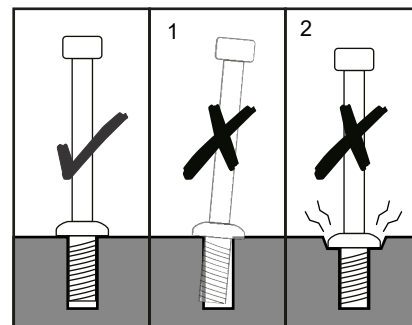
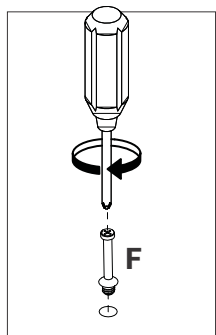
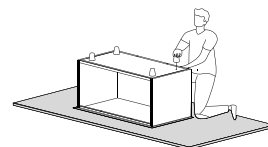

Étape / Paso 4

(FR)

Fixer les Glissières (35) dans le Panneau Gauche (27) et Panneau Droit (28) avec le Vis (C) et un clé Phillips.

(ES)

Fije las Correderas (35) en el Panel Izquierdo (27) y Panel Derecho (28) utilizando Tornillos (C) y la llave Phillips.

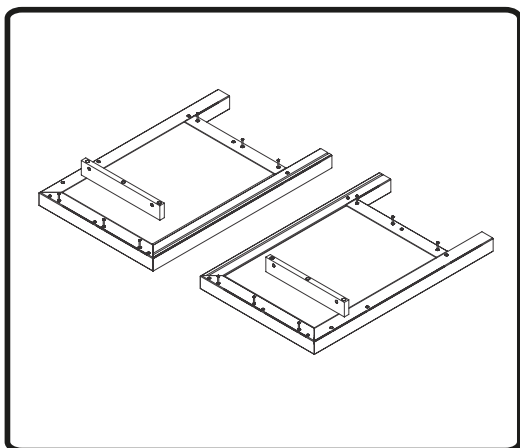
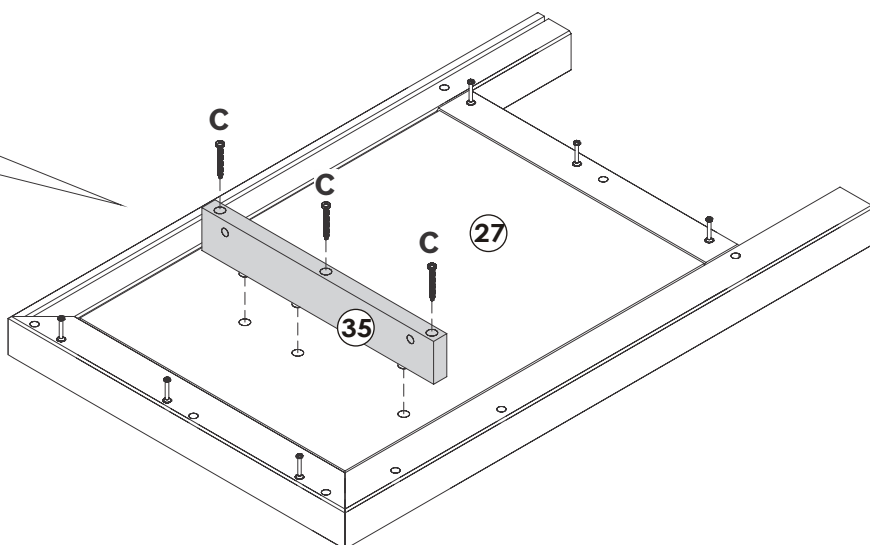
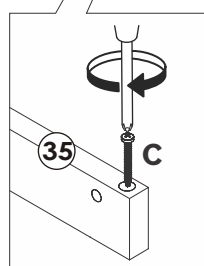
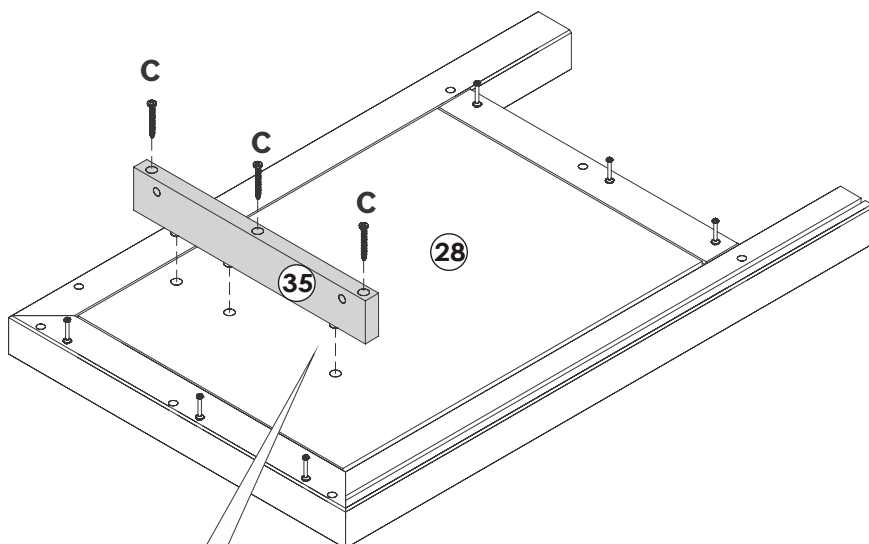
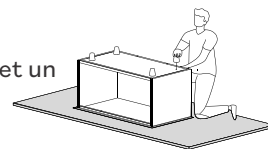

Étape / Paso 5

(FR)

Monte le Panneau Inférieur (26) dans le Panneau Gauche (27). Insère le Boitier de Assemblage (E) dans le Panneau Inférieur (26) avec un clé Phillips.

(ES)

Encaje el Panel Inferior (26) en el Panel Izquierdo (27). Inserta la Traba del Conector (E) en el Panel Inferior (26) y fije con una llave Phillips.

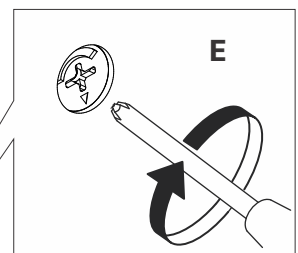
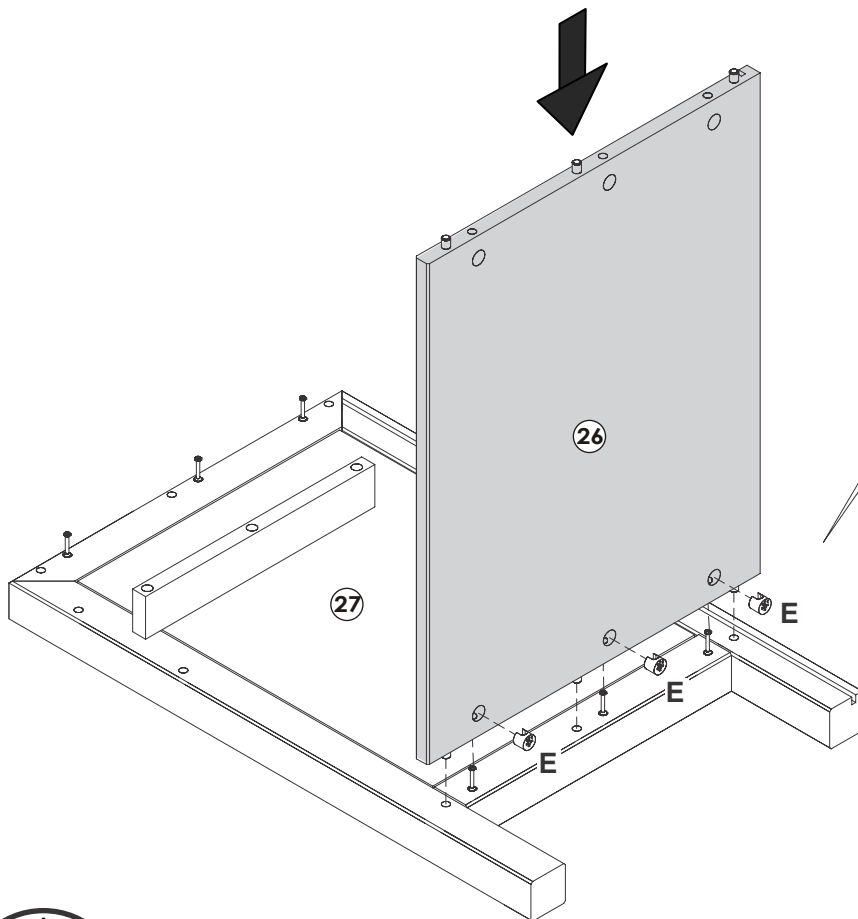
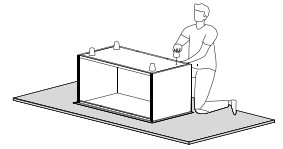

PASSO PRONTO
PASSO PRONTO

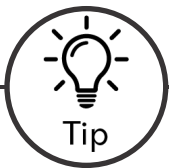
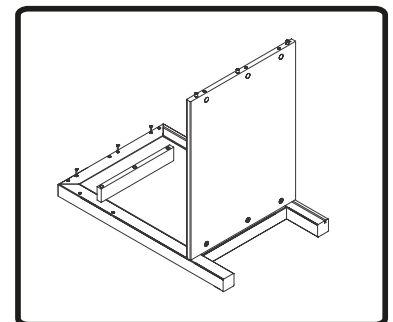

Tip

Cam Locks

Cam Locks help securely join two pieces together.

Follow these easy steps.

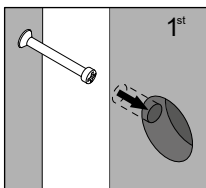

1: Insert Cam Bolt into bolt holes on the flat side. Don't over tighten!

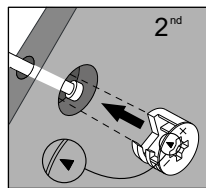

2: Assemble both parts together. The cam bolts goes in the drills holes that have a circular hole on the side, you should be able to see the cam bolt through it. After fitting parts together insert the cam lock on the side holes.

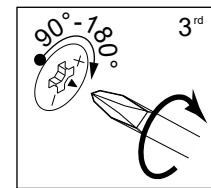

3: On the back of the Cam Lock will be a 'C' shape. Insert the Cam Lock so the opening of the 'C' fits over the Cam Bolt. Tighten with the screwdriver.

Étape / Paso 6

(FR)

Monte le Panneau de Façade (4) et le Panneau Supérieur au Panneau Gauche (27) avec l'aide des Boitiers de Assemblage (E) et un tournevis Phillips.

(ES)

Encaje el Panel Delantero (4) y el Panel Superior (21) en el Panel Izquierdo (27). Aprieta utilizando las Trabas del Conector (E) y un destornillador Phillips.

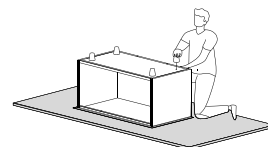

1st

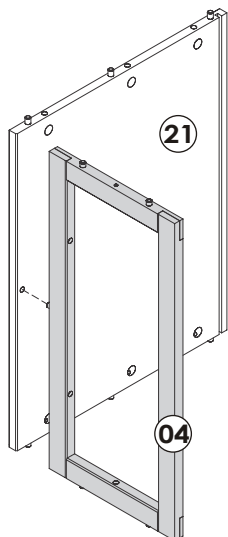

Fixe o Quadro Frontal (04) no Tampo (21).

2nd

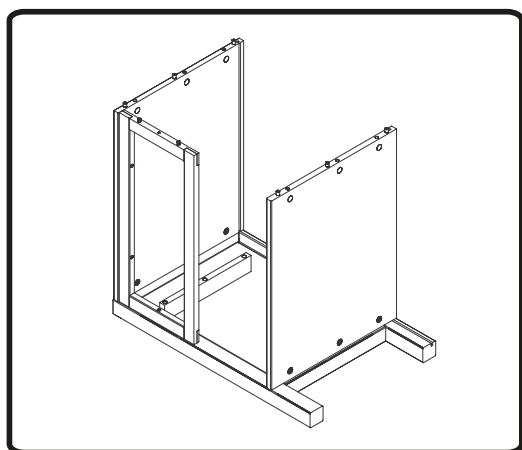
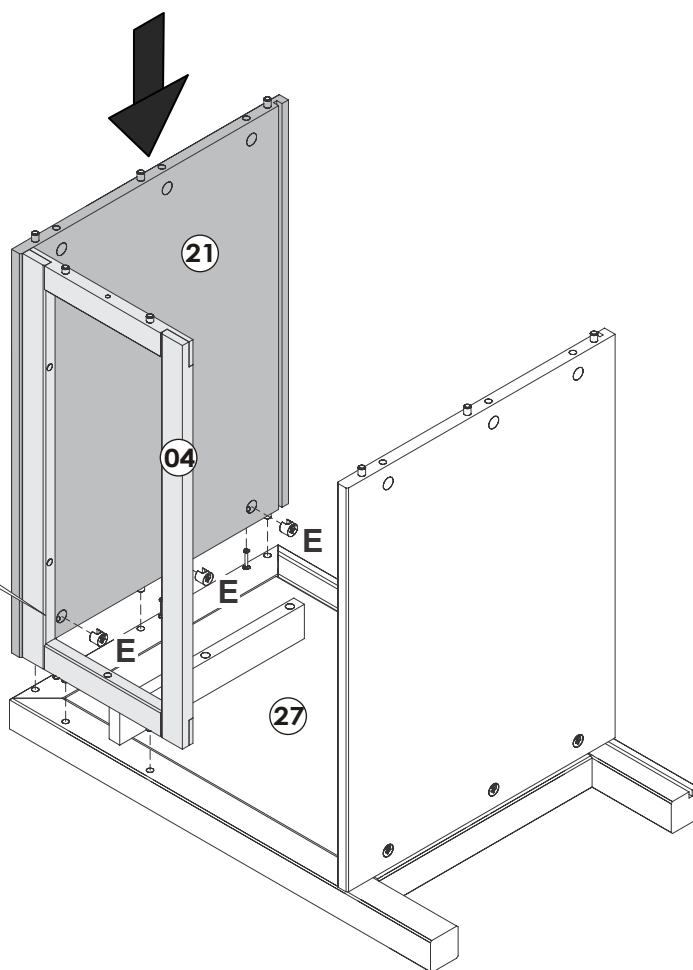
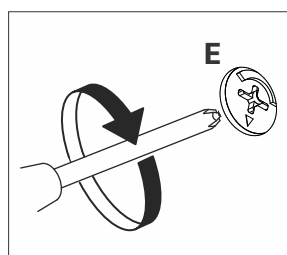

Étape / Paso 7

(FR)

Insérez le Profil "H" (J) dans le Panneau Arrière (42). Ensuite, faites glisser le Panneau Arrière (42) dans les rainures du Panneau Supérieur (21) et le Panneau Inférieur (26) et placez-le dans le Panneau Gauche (27).

(ES)

Inserte el Perfil "H" (J) en el Panel Trasero (42). Luego, deslice el Panel Trasero (42) dentro de las ranuras del Panel Superior (21) y el Panel Inferior (26) colóquelo en el Panel Lateral Izquierdo (27).

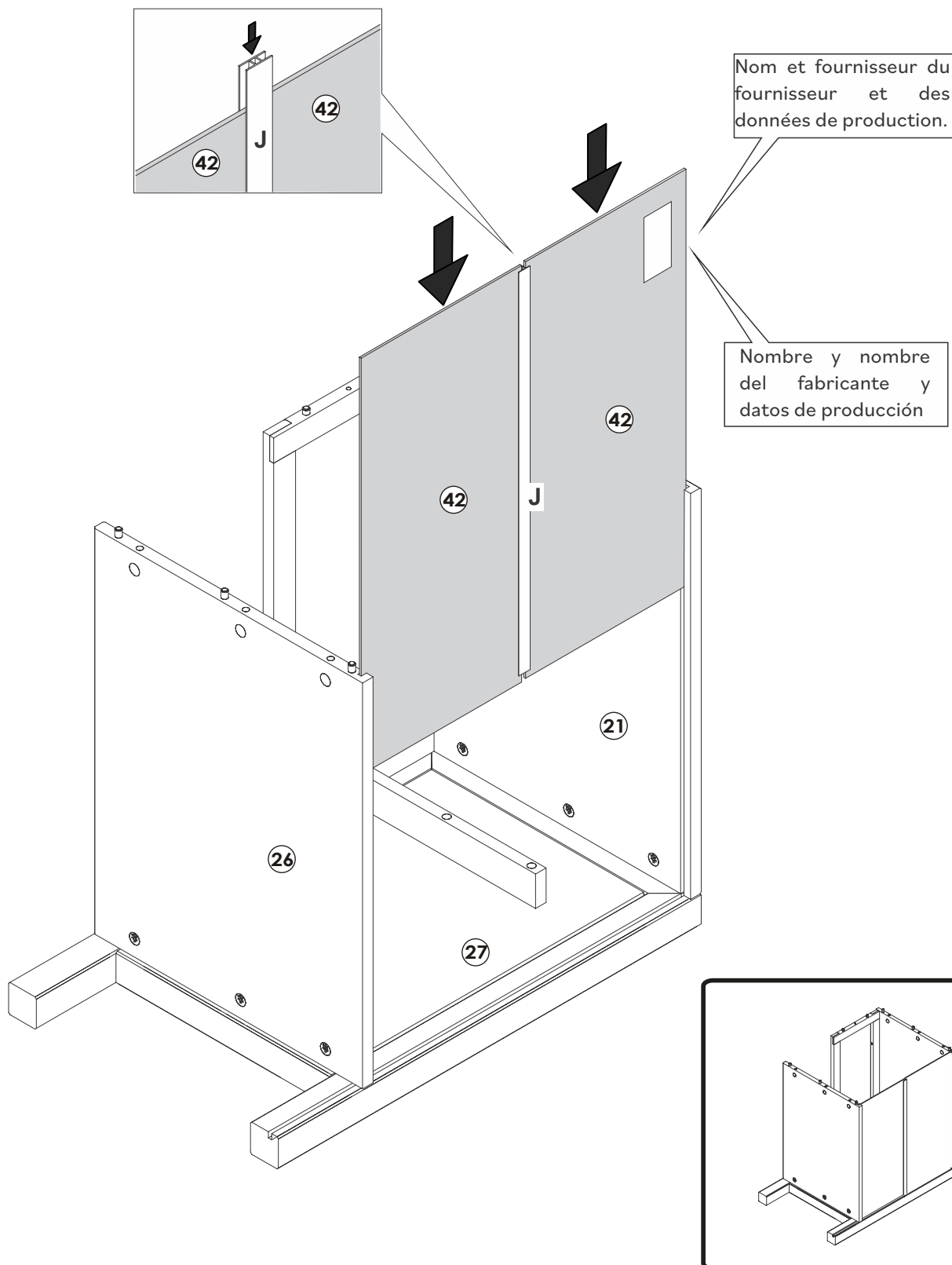
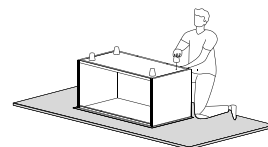

Étape / Paso 8

(FR)

Installez le Panneau Droit (28) sur le Panneau du Façade (04), Panneau Supérieur (21), Panneau Inférieur (26) et l'Panneau Arrière (42). Insérez le Boitier de Assemblage (E) dans le Panneau Supérieur (21) et de le Panneau Inférieur (26) et fixez-la avec le tournevis Phillips.

(ES)

Coloque el Lado Derecho (28) en el Panel Delantero (04), Panel Superior (21), Panel Inferior (26) y el Panel Trasero (42). Inserte la Traba del Conector (E) en los agujeros del Panel Superior (21) y Panel Inferior (26) y asegúrelo con el destornillador Phillips.

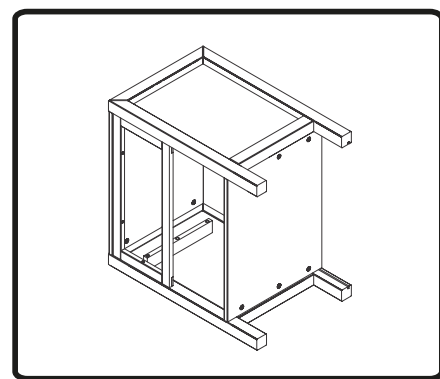
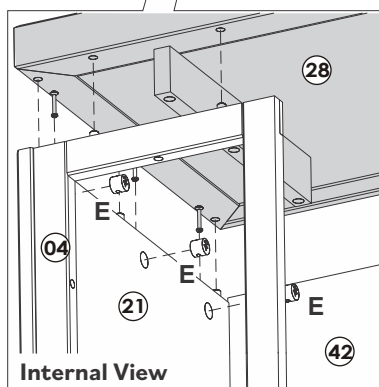
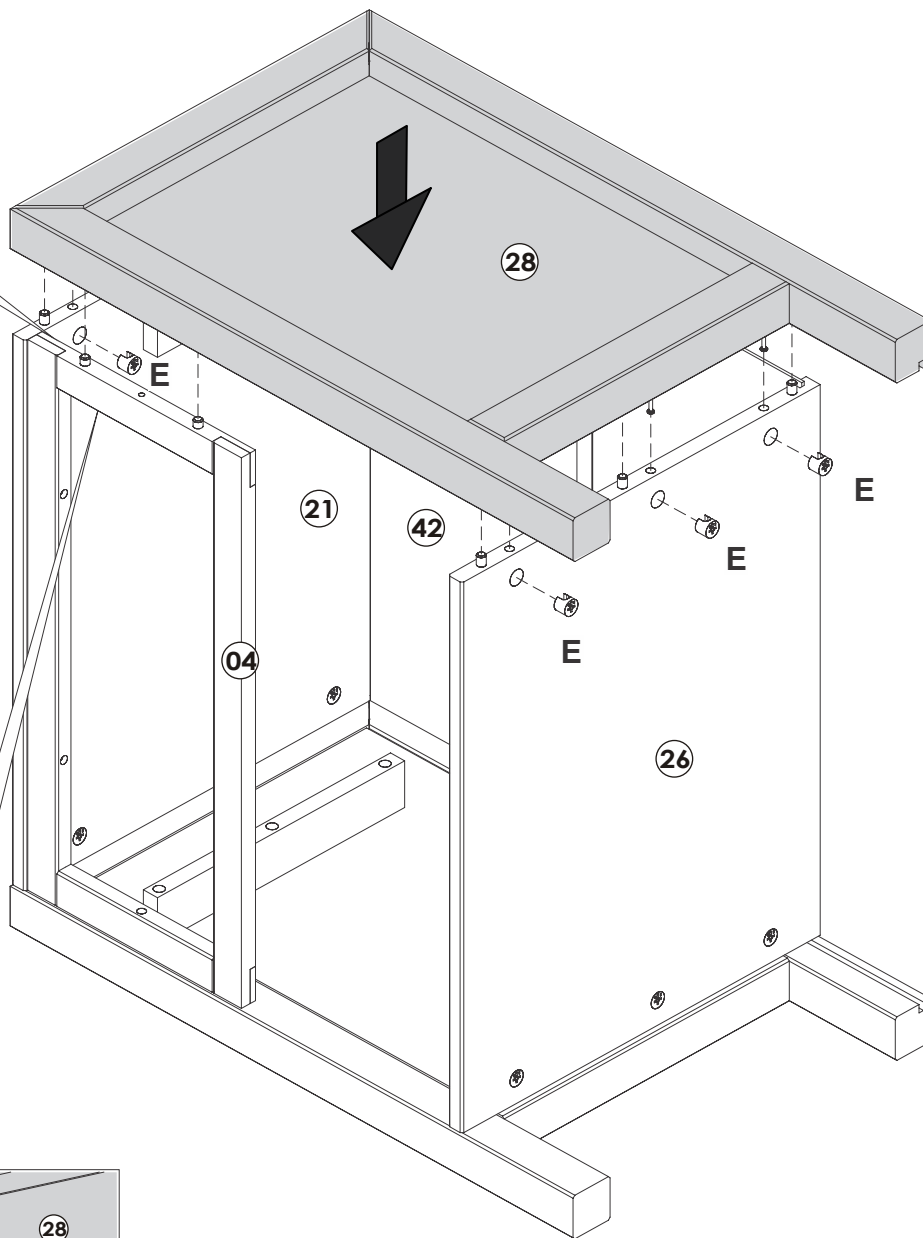
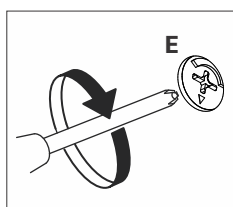
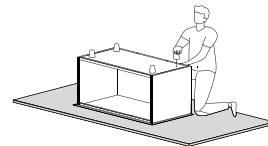

Étape / Paso 9

(FR)

Fixez le Panneau du Façade (04) sur le Panel Supérieur (21), Panneau Gauche (27) et Panneau Droit (28) avec la Vis (C) et un tournevis Phillips.

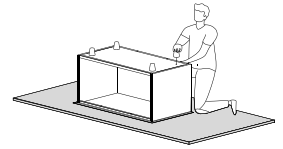

(ES)

Fije el Panel Delantero (04) en el Panel Superior (21), Panel Izquierdo (27) y Panel Derecho (28) con el Tornillo (C) y un destornillador Phillips.

Rotate 90°

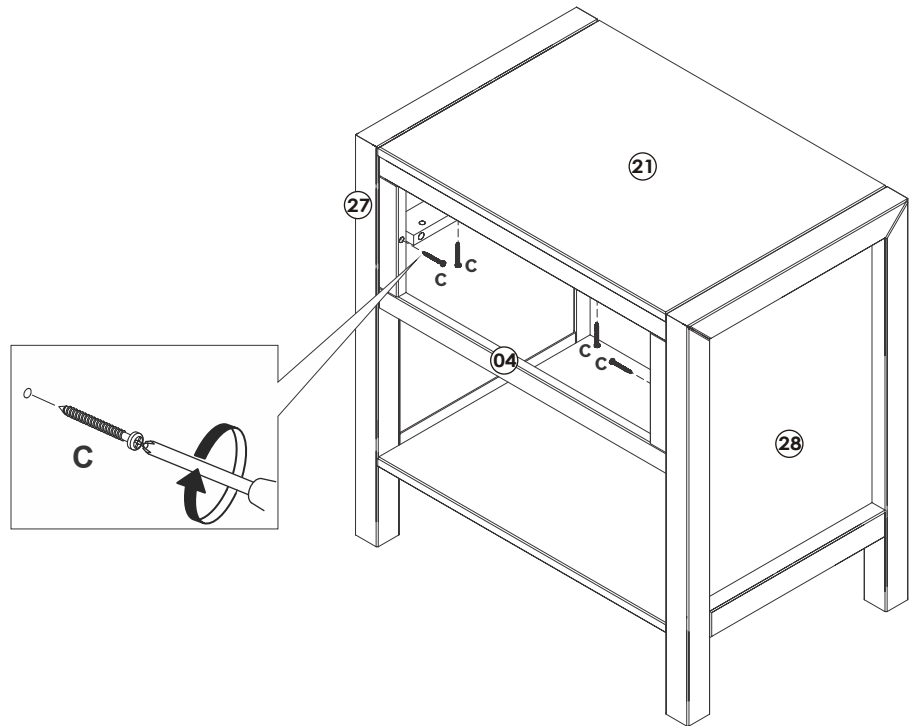
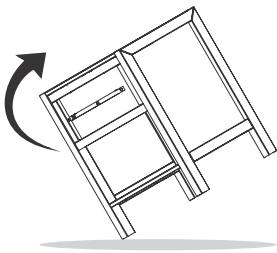

Étape / Paso 10

(FR)

Insérez la Cheville (A) dans le trou avant de la Glissière (35)

(ES)

Inserte la Clavija (A) en el agujero frontal de la Corredera (35).

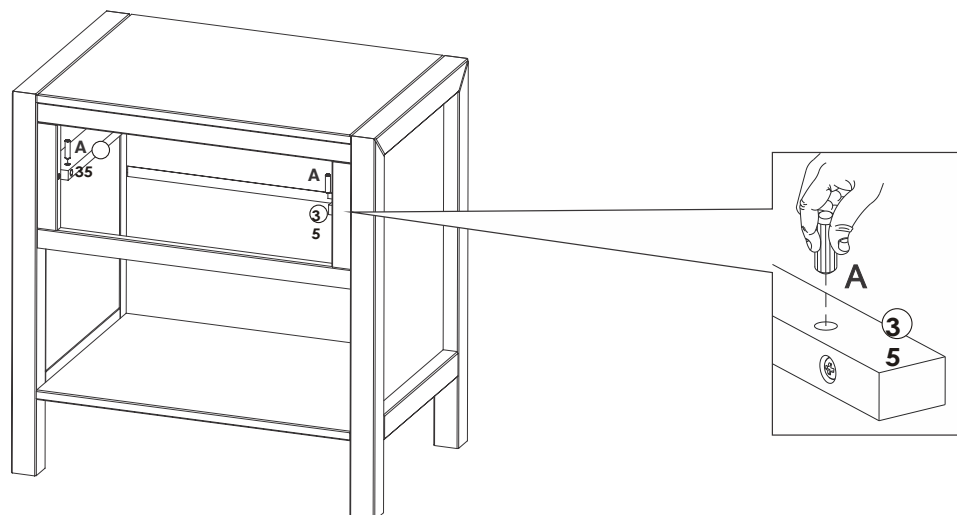

Étape / Paso 11

(FR)

Installez les Goujons de Assemblage (F) sur la Façade du Tiroir (19) le Côté Gauche du Tiroir (32), le Côté Droit du Tiroir (33) et fixez-les avec le Boitier de Assemblage (E) et un tournevis Phillips.

(ES)

Coloque los Conectores (F) en el Frente del Cajón (19) en el Lado Izquierdo del Cajón (32), en el Lado Derecho del Cajón (33) y fijelos con la Traba del Conector (E) y un destornillador Phillips.

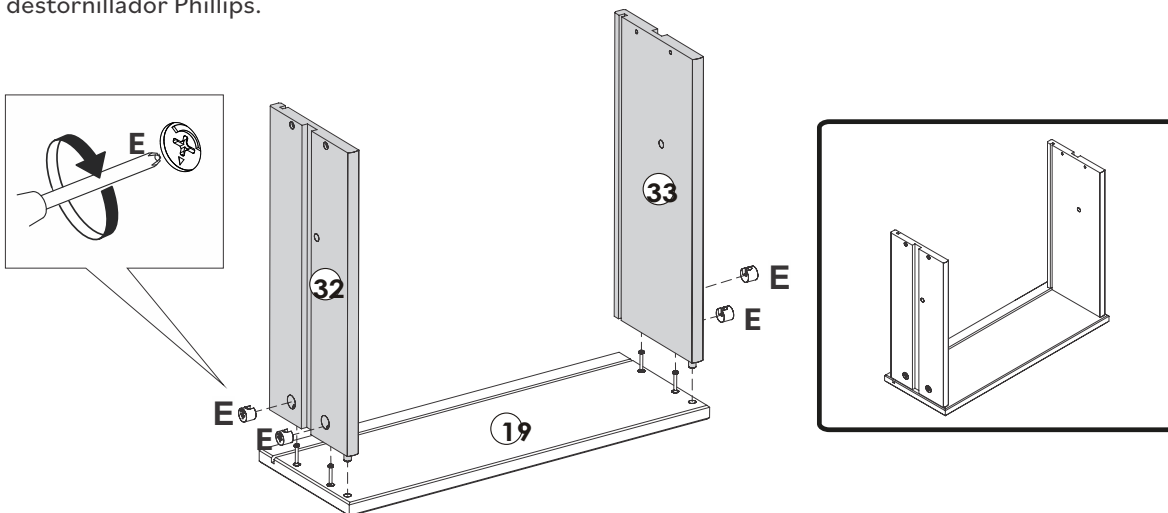
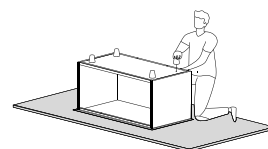

Étape / Paso 12

(FR)

Faites glisser le Fond du Tiroir (11) sur les rainures des Côtés Droit et Gauche du Tiroir (32/33) en s'adaptant à la Façade du Tiroir (19). Fixez l'Arrière du Tiroir (20) aux Côtés Droit et Gauche du Tiroir (32/33) à l'aide des Vis (G) et d'un tournevis Phillips.

(ES)

Deslice la Parte Inferior del Cajón (11) en las ranuras de los Lados Derecho e Izquierdo del Cajón (32/33) que encajan en el Frente del Cajón (19). Fije la Parte Trasera del Cajón (20) al Lado Derecho e Izquierdo del Cajón (32/33) usando Tornillos (G) y un destornillador Phillips

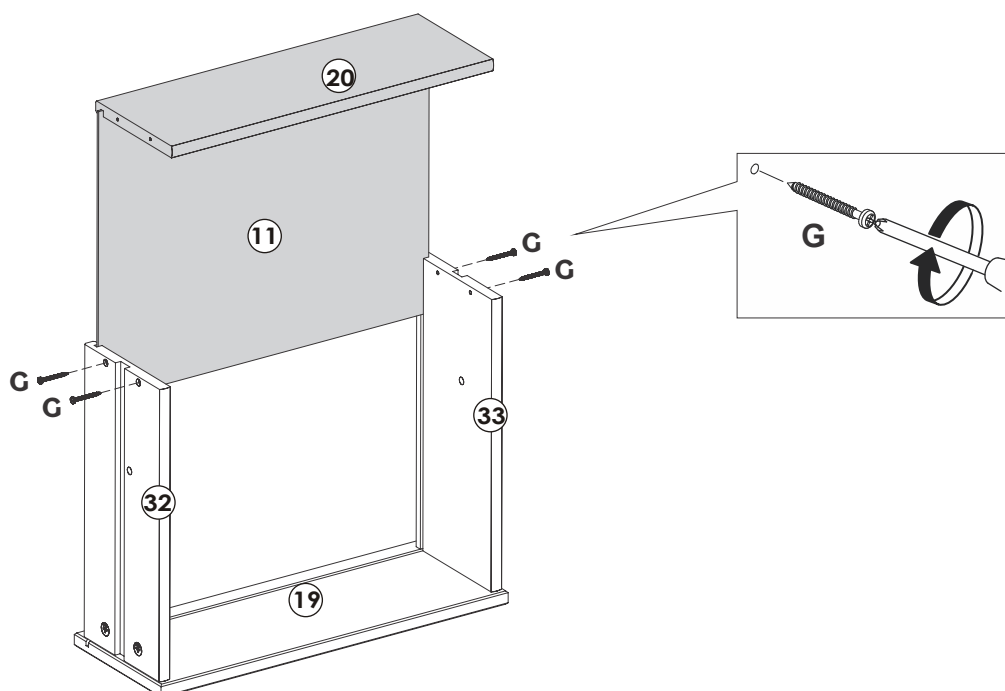

Étape / Paso 13

(FR)

Fixez la Poignée (I) avec la Vis (D) et un tournevis Phillips.

(ES)

Fije el Manillo (I) con el Tornillo (D) y un destornillador Phillips.

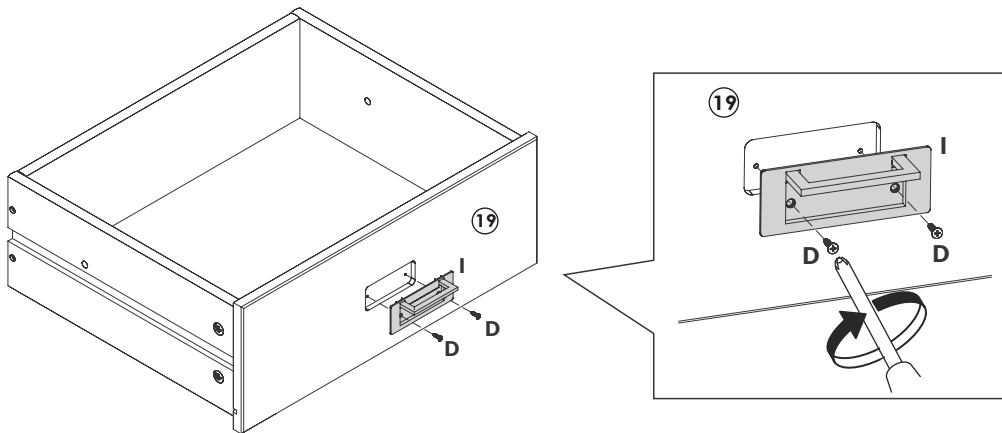
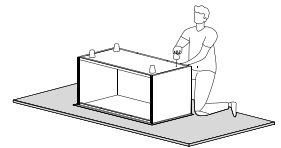

Étape / Paso 14

(FR)

Insérez la Cheville en bois (H) à l'intérieur de tous les tiroirs avec le tiroir à l'intérieur du meuble, après avoir passé à travers la cheville en bois qui se trouve dans la glissière du tiroir. La goupille n'affleure pas le panneau, elle se trouve légèrement à l'intérieur du tiroir pour vous aider lorsque vous devez retirer la goupille de verrouillage pour retirer le tiroir.

(ES)

Inserte la Espiga (H) en el interior de todos los cajones con el cajón dentro de la unidad, después de pasar a través de la espigade madera que se encuentra en la corredera del cajón. El pasador no está al ras con el panel, está ligeramente dentro del cajón para ayudar cuando necesite quitar el pasador de bloqueo para retirar el cajón.

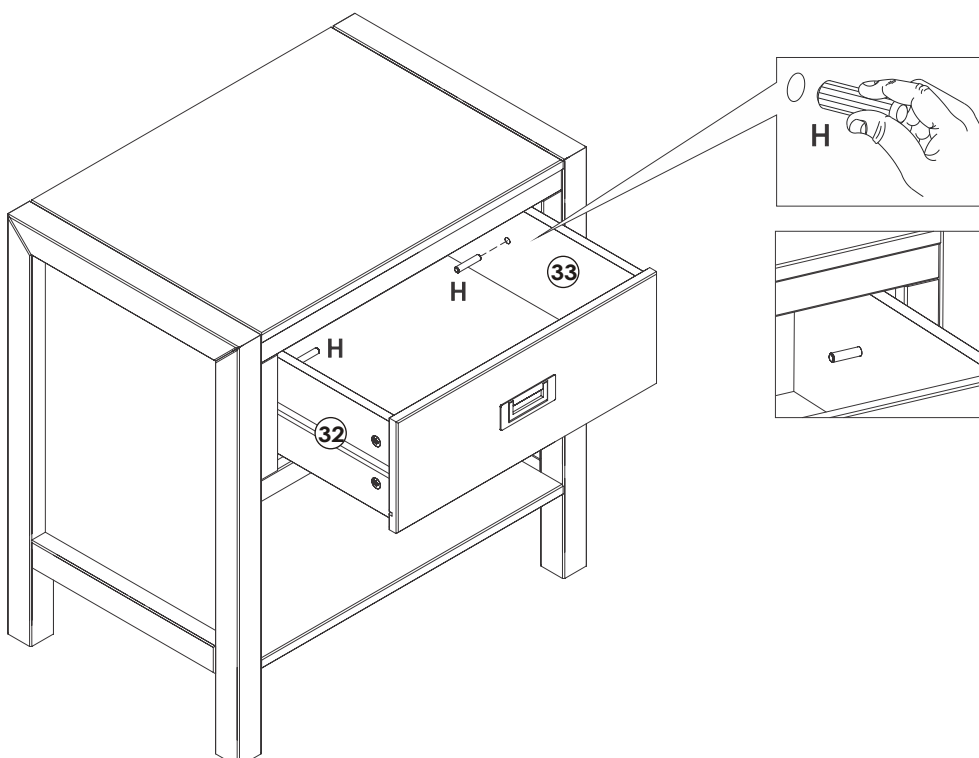

Vous avez réussi ! Profitez de votre nouvelle table de chevet !

Lo has conseguido! Disfruta de tu nueva mesita de noche !

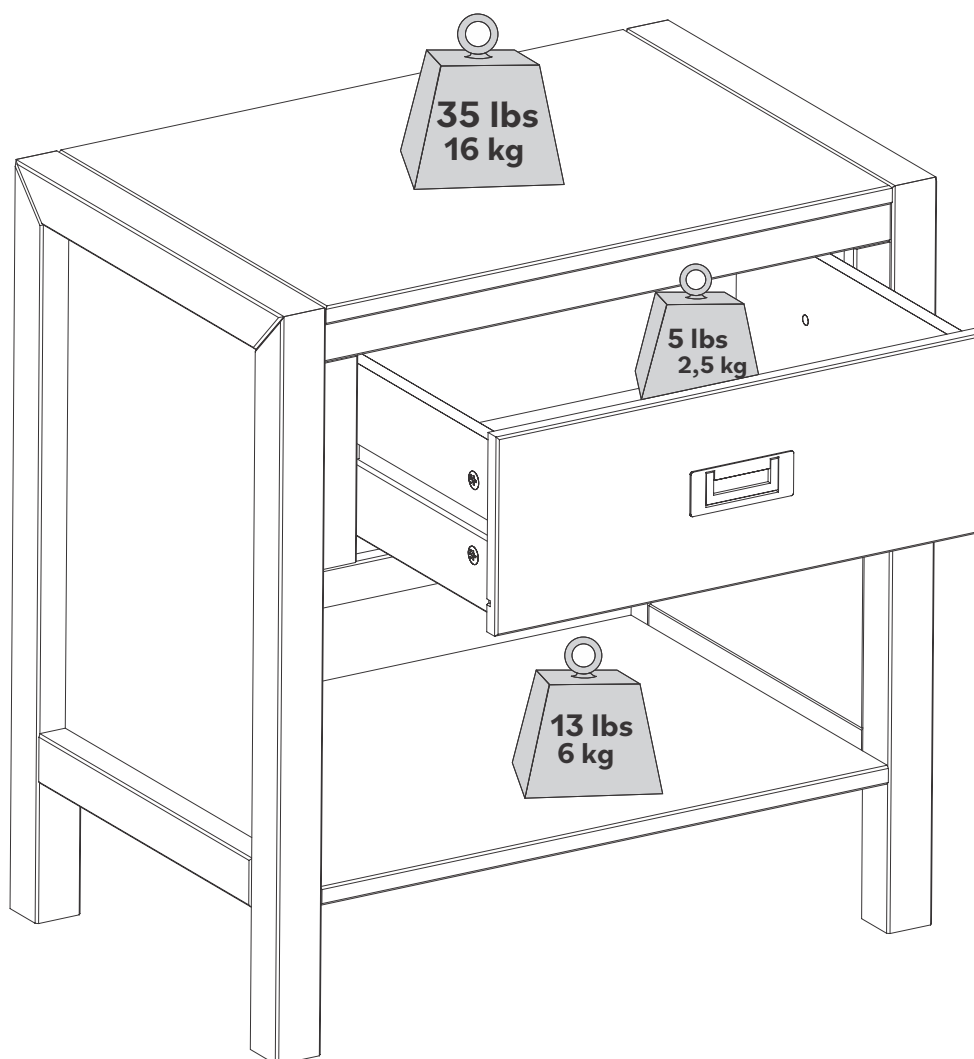

**Félicitations pour votre nouveau meuble!
Nous serions ravis d'en entendre parler et de le voir.
Laissez-nous un commentaire ou postez une photo
avec le mot-clé #mywalkerredisonhome**

**Enhorabuena por su nuevo mueble!
Nos encantaría conocerlo y verlo.
Por favor, déjenos un comentario o
publique una foto con #mywalkerredisonhome**

Assembler des meubles peut parfois être compliqué.

Notre équipe de service client, située dans l'Utah, est là pour obtenir des informations sur les produits, aider pour l'assemblage d'un produit ou pour tout autre problème de support client.

Appelle-nous **801-433-3008**

Envoie-nous les e-mails à **service@walkeredison.com**

Visite notre site accueil au client à

walkeredison.com/pages/customer-service

Nous sommes disponibles pour t'aider du Lundi au Jeudi de 8 am - 5 pm, Vendredi de 8 am - 3 pm MST.

Pour plus de détails sur les vidéos d'assemblage, les instructions d'assemblage, les pièces de rechange et le service client.

NUMÉRISER ICI.



Pour le nettoyage, n'utilise jamais d'abrasifs, utilise un chiffon doux et de l'eau avec du savon neutre pour nettoyer les meubles

A veces, montar muebles puede resultar complicado.

Nuestro equipo de atención al cliente, ubicado en Utah, está a su disposición para informarle sobre los productos, ayudarle a montarlos o resolver cualquier otro problema de atención al cliente.

Llámenos **801-433-3008**

Envíenos un correo electrónico a **service@walkeredison.com**

Visite nuestra página web de atención al cliente

walkeredison.com/pages/customer-service

Estamos a su disposición para ayudarle de lunes a jueves de 8:00 a 17:00, viernes de 8:00 a 15:00 MST.

Para más detalles sobre videos de montaje, instrucciones de montaje, piezas de recambio y servicio de atención al cliente

ESCANEE AQUÍ



Para la limpieza, nunca utilice productos abrasivos, utilice un paño suave y agua con jabón neutro para limpiar los muebles