

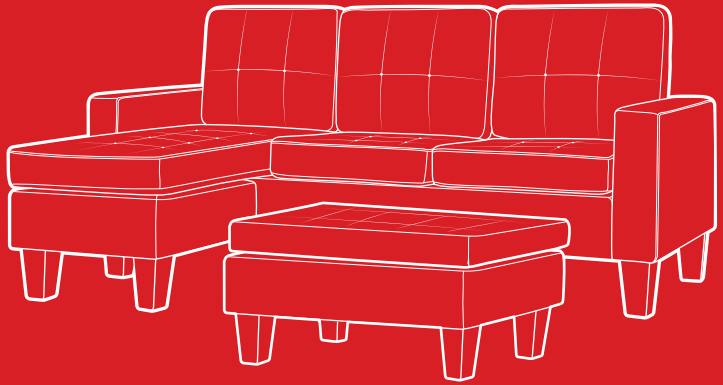

bestchoiceproducts



INSTRUCTION MANUAL

2-Piece L-Shaped
Sectional w/ Ottoman



Hardware & parts
are located in
the compartment
underneath the sofa.

Make sure to
remove all items
before assembly.

bestchoiceproducts.com

! NOTICE

Please retain these instructions for future reference.

- Please do not exceed the weight limitations of this item.
- Do not stand on or jump on any part of this item.
- Firmly secure all bolts and knobs before use.
- Reconfirm that all bolts and knobs are secure every 90 days.
- Do not use or store this item in the proximity of open flame or flammable/combustible chemicals.
- Be aware that some parts are heavy and have sharp edges.
- If any parts are missing, broken, damaged, or worn, stop using this product until repairs are made and/or factory replacement parts are installed.
- Do not use this item in a way inconsistent with the manufacturer's instructions as this could void the product warranty.

TOOLS REQUIRED



WRENCH
(PROVIDED)



500 LBS
CAPACITY



1 PERSON
ASSEMBLY



APPROXIMATELY
30 MIN.
ASSEMBLY

HARDWARE

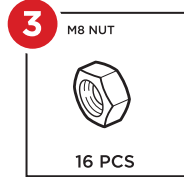
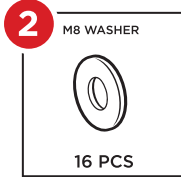
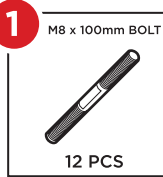

PARTS

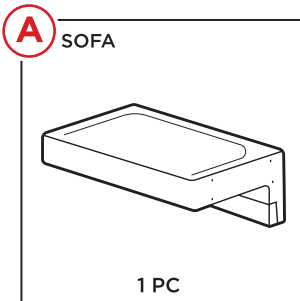

Parts and/or hardware located underneath this sofa.

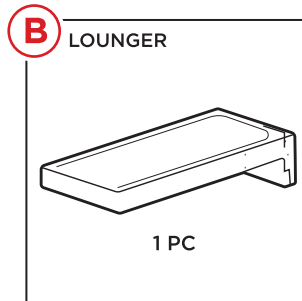

Parts and/or hardware located underneath this lounge.

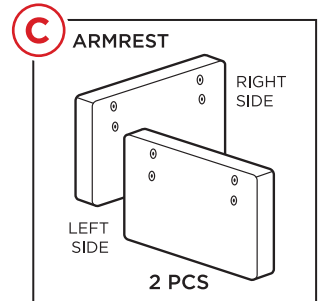

Hidden under compartment.

CALIFORNIA PROPOSITION 65

! WARNING: This product can expose you to Diisononyl phthalate (DINP), which is known to the State of California to cause cancer. For more information go to www.P65Warnings.ca.gov

PARTS

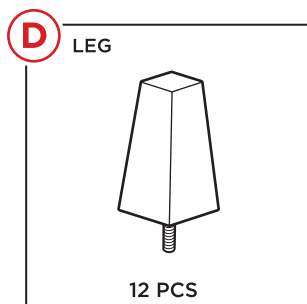

Hidden under compartment.

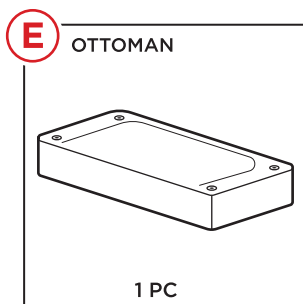

Parts and/or hardware located underneath this ottoman.

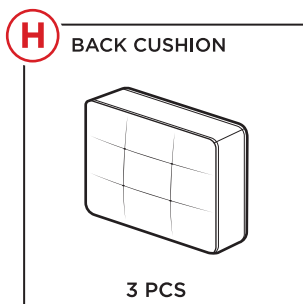
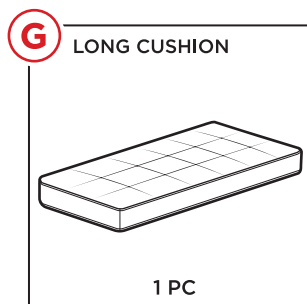
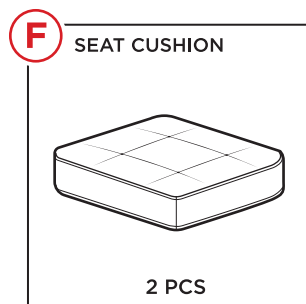

Hidden under compartment.

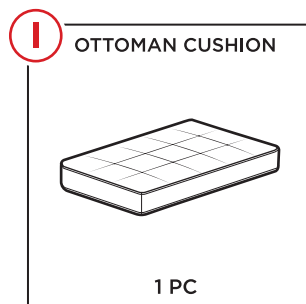

PRODUCT ASSEMBLY

1

Remove the parts and hardware from the compartment underneath the furniture.
Use your hand to screw eight part 1 bolts into two part C armrests, four bolts per armrest.

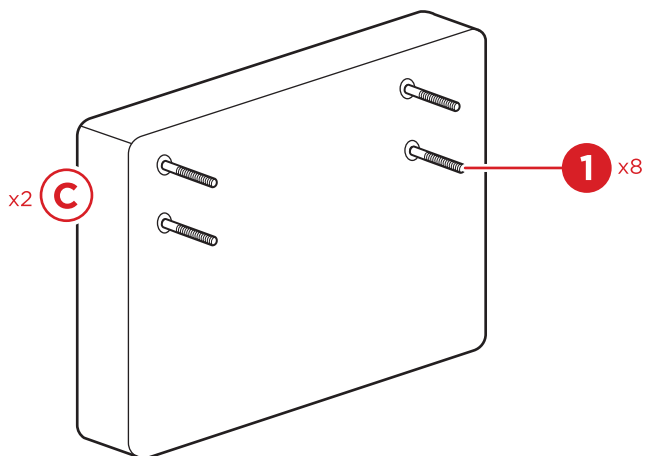

PRODUCT ASSEMBLY

2

From within the compartment, attach an armrest to the part A sofa with four part 2 washers and four part 3 nuts. Screw in four part D legs.

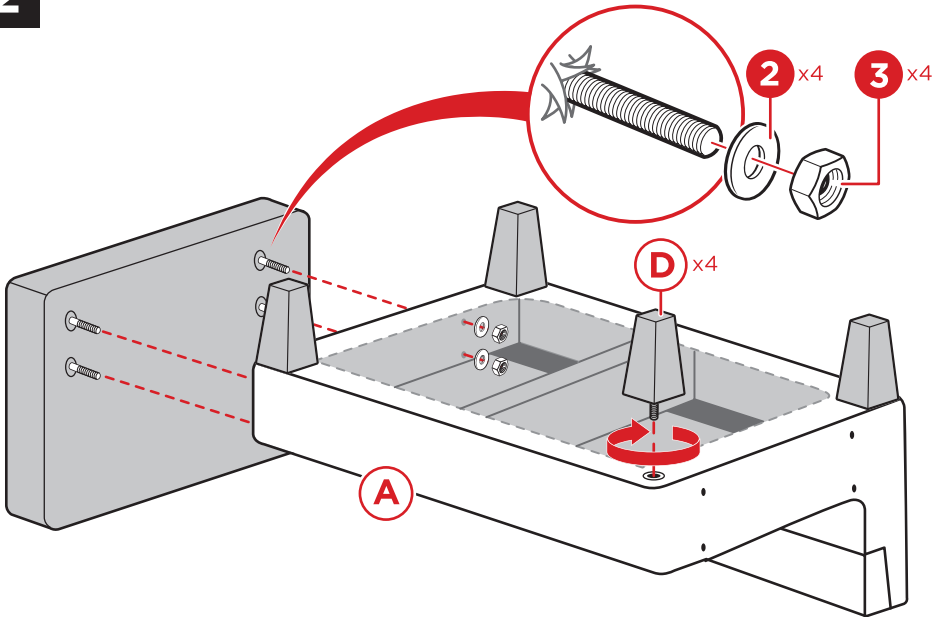

3

From within the compartment, attach an armrest to the part B lounge with four part 2 washers and four part 3 nuts. Screw in four part D legs.

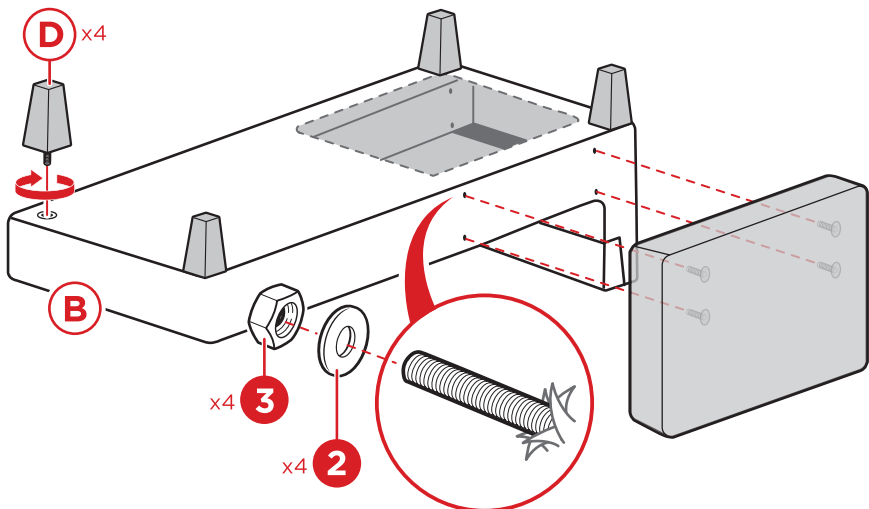

PRODUCT ASSEMBLY

4

Attach the sofa to the lounger with four part 1 bolts, eight part 2 washers, and eight part 3 nuts.

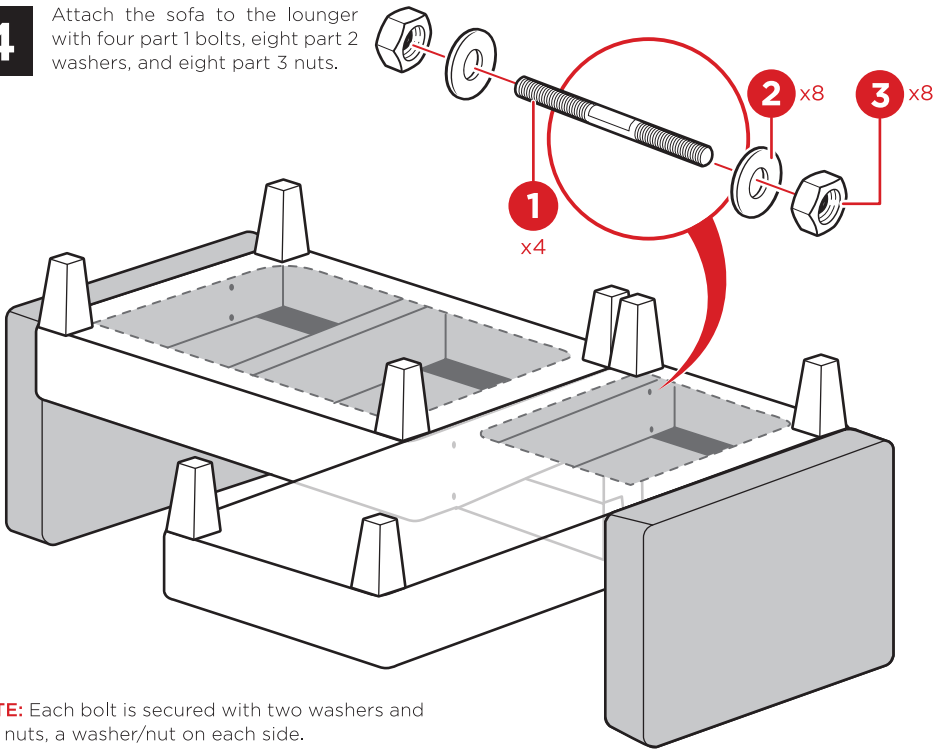

NOTE: Each bolt is secured with two washers and two nuts, a washer/nut on each side.

5

Flip up the backrest on the sofa and lounger. Place two part F seat cushions, a part G long cushion, and three part H back cushions.

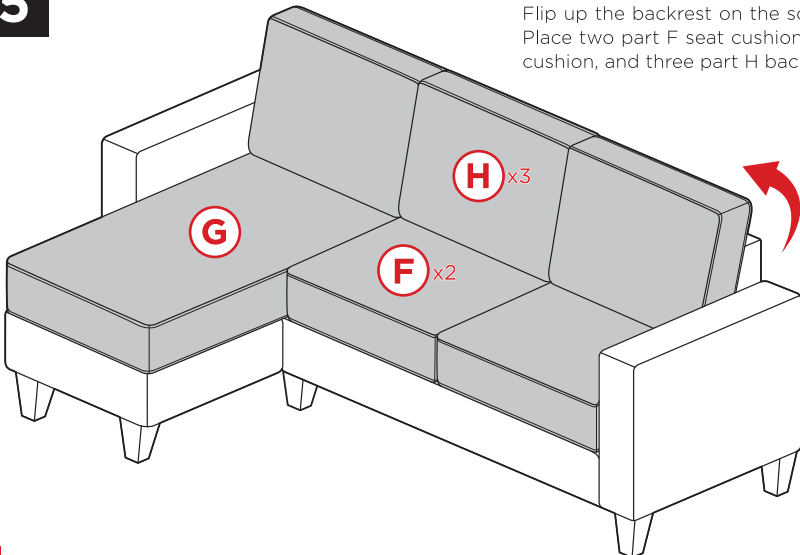

PRODUCT ASSEMBLY

6

Screw four part D legs into the part E ottoman.

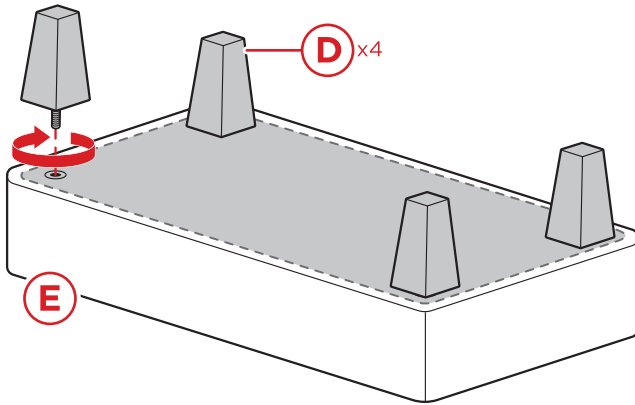

7

Place the part I ottoman cushion.

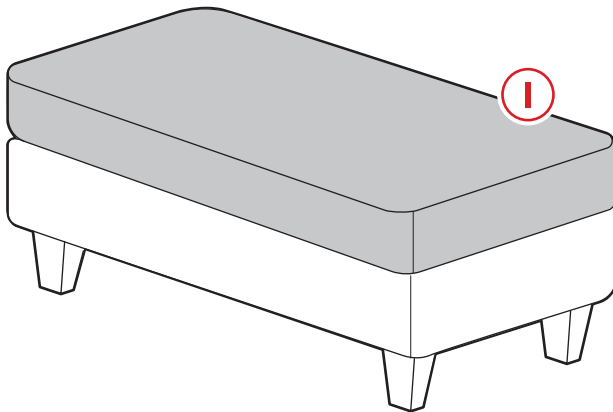

ARRANGEMENT OPTIONS

You can rearrange the sectional and cushions according to your preference.

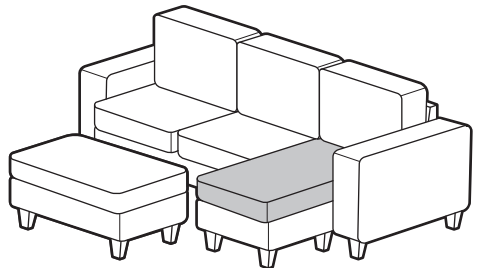
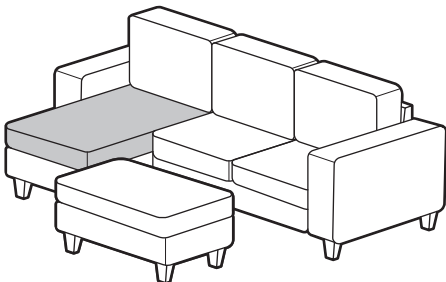



HELP CENTER



Question about your product? We're here to help. Visit us at:

help.bestchoiceproducts.com



Chat Support



Product Inquiry



Orders FAQ



Product Assembly



Returns & Refunds

PRODUCT WARRANTY INFORMATION

All items can be returned for any reason within 60 days of the receipt and will receive a full refund as long as the item is returned in its original product packaging and all accessories from its original shipment are included. All returned items will receive a full refund back to the original payment method. All returned items will not be charged a re-stocking fee.

All returned items require an RA (Return Authorization) number, which can only be provided by a Best Choice Products Customer Service Representative when the return request is submitted. Items received without an RA may not be accepted or may increase your return processing time. Once an item has been received by Best Choice Products, refunds or replacements will be processed within 5 business days.

All returns must be shipped back to the Best Choice Products Return Center at the customer's expense. If the reason for return is a result of an error by Best Choice Products then Best Choice Products will provide a pre-paid shipping label via email. Boxes for return shipping will not be provided by Best Choice Products, and is the customer's responsibility to either use the original shipping boxes or purchase new boxes.

Pictures may be required for some returns to ensure an item is not damaged prior to its return. Items returned are not considered undamaged until they are received by Best Choice Products and verified as such. All damages to items are the customer's responsibility until the item has been received by and acknowledge by Best Choice Products as undamaged.



WARNING

Manufacturer and seller expressly disclaim any and all liability for personal injury, property damage or loss, whether direct, indirect, or incidental, resulting from the incorrect attachment, improper use, inadequate maintenance, or neglect of this product.